



**Makita**®

**2022/23**

**GENERAL CATALOGUE**



**Version 2.0**



Product Category



20 Drill - Steel & Wood



47 Cutting- Masonry & Concrete



93 Pressure Washer



24 Hammer Drill - Steel, Wood & Masonry



49 Metal Cutting



94 Heat Gun



26 Impact Driver



54 Grinder



95 Nailer



29 Impact Wrench



65 Sawing



98 Speciality Tools



33 Screwdriver



68 Circular Saw

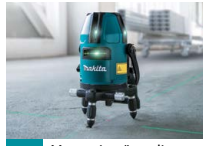

101 Measuring/Leveling



34 Mixer



72 Jig Saw



103 Comfort/Lifestyle



35 Stationary Drill



73 Planing & Routing



107 Lights



36 Rotary Hammer

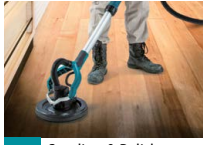

76 Sanding & Polisher

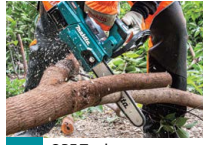

112 OPE Tools



42 Demolition Hammer



81 Dust Extraction



127 Cordless Tools For Industry



45 Recipro Saw



92 Power Cutter



133 MT Series

Index	
1	
1805N	74
1911B	74
2	
2012NB	74
2107FK	51
2416S	52
2712	67
3	
3600H	76
3601B	76
3711 <b>NEW</b>	75
4	
4100KB	48
4100NH	47
4100NH3Z	48
4100NH3Z/B	48
4107R	48
4112HS	48
4114S	48
4114S/B	48
4131	50
4300BV	73
4327M	72
4403	76
5	
5008MG	71
5103N	71
5806B	71
5806B/B	71
6	
6305	23
6412	23
6412/B	23
6413	23
6906	32
6922NB	33
6924N	33
9	
9031	80
9035H	79
9218SB	79
9237C	78
9401	80
9500NB	59
9556HBG	59
9556HNG	59
9556HP/BX	60
9556PBG	60
9557HNG	61
9558HNG	61
9924DB	80
A	
AF201Z	96
AF301	97
AF353	96
AF506	97
AF635	97
AS001GZ02 <b>NEW</b>	82
AT1022AZ	97
AT638A	97
B	
BO3710	79
BO4510H	80
BO4556	80
BO4900V	80
BO5031	78
BO6050J	77
BTW073Z	132
BTW074Z	132
BTW103Z	132
B	
BTW104Z	132
BTW130Z	132
C	
CAS5000X	53
CC301DSYE / DZ	47
CE001GZ01 <b>NEW</b>	92
CF001GZ	103
CF002GZ <b>NEW</b>	103
CF100DZ	104
CF101DZ / DZX1	103
CG100DZA	99
CL001GD115(RD/T+B)	87
CL001GD126(RD/T+W)	87
CL001GZ12(Z/T+W)	87
CL001GZ204(Z/T+B)	87
CL002GD110(RDB) <b>NEW</b>	87
CL002GD116(RDW) <b>NEW</b>	87
CL002GZ03(ZB) <b>NEW</b>	87
CL002GZ07(ZW) <b>NEW</b>	87
CL003GD114(RDW) <b>NEW</b>	87
CL003GD115(RDB) <b>NEW</b>	87
CL003GZ09(ZB) <b>NEW</b>	87
CL003GZ14(ZW) <b>NEW</b>	87
CL100DW / DZX	89
CL102DW / DWX	89
CL104DWR / DWY / DWYX	89
CL105DWR / DWX	89
CL106FDSA / FDZ	88
CL107FDSA / FDZW / FDZ / FDSA	89
CL108FDSA / FDZ / FDZW	89
CL117FDX2 <b>NEW</b>	89
CL121DSAX1 / DSA / DZ	87
CLX224SAX1	126
CP100DSA / DZ	100
CS002GZ <b>NEW</b>	49
CW001GZ <b>NEW</b>	104
CW002GZ <b>NEW</b>	104
CW003GZ <b>NEW</b>	104
D	
DA3010F	23
DA330DWE	23
DA331DWE	23
DA332DZ	22
DA333DSAE / DZ	22
DBO180Z	77
DBO380RTJ / Z <b>NEW</b>	79
DBO481RTJ / Z <b>NEW</b>	80
DBS180Z	80
DCC500RTE / Z	47
DCE090ZX2 / Z	92
DCF102ZX1	103
DCF203Z	103
DCF301Z <b>NEW</b>	103
DCG180ZB / Z / ZK	99
DCL180FZW / FRGW / FZW1	88
DCL180Z / ZB / RTB	88
DCL181FZW / FZW1	88
DCL182ZB / ZW	88
DCL184Z	87
DCL280FZB / FZW / BX12 / FZW1	88
DCL281FZB / FZW	88
DCL282FRAW / FZW	88
DCMS01Z	104
DCO181Z	74
DCS552Z	49
DCS553Z	49
DCU180Z	116
DCW180Z	104
DDA351Z	22
DDF083RFE / Z	21

Index	
1	
1805N	74
1911B	74
2	
2012NB	74
2107FK	51
2416S	52
2712	67
3	
3600H	76
3601B	76
3711 <b>NEW</b>	75
4	
4100KB	48
4100NH	47
4100NH3Z	48
4100NH3Z/B	48
4107R	48
4112HS	48
4114S	48
4114S/B	48
4131	50
4300BV	73
4327M	72
4403	76
5	
5008MG	71
5103N	71
5806B	71
5806B/B	71
6	
6305	23
6412	23
6412/B	23
6413	23
6906	32
6922NB	33
6924N	33
9	
9031	80
9035H	79
9218SB	79
9237C	78
9401	80
9500NB	59
9556HBG	59
9556HNG	59
9556HP/BX	60
9556PBG	60
9557HNG	61
9558HNG	61
9924DB	80
A	
AF201Z	96
AF301	97
AF353	96
AF506	97
AF635	97
AS001GZ02 <b>NEW</b>	82
AT1022AZ	97
AT638A	97
B	
BO3710	79
BO4510H	80
BO4556	80
BO4900V	80
BO5031	78
BO6050J	77
BTW073Z	132
BTW074Z	132
BTW103Z	132
B	
BTW104Z	132
BTW130Z	132
C	
CAS5000X	53
CC301DSYE / DZ	47
CE001GZ01 <b>NEW</b>	92
CF001GZ	103
CF002GZ <b>NEW</b>	103
CF100DZ	104
CF101DZ / DZX1	103
CG100DZA	99
CL001GD115(RD/T+B)	87
CL001GD126(RD/T+W)	87
CL001GZ12(Z/T+W)	87
CL001GZ204(Z/T+B)	87
CL002GD110(RDB) <b>NEW</b>	87
CL002GD116(RDW) <b>NEW</b>	87
CL002GZ03(ZB) <b>NEW</b>	87
CL002GZ07(ZW) <b>NEW</b>	87
CL003GD114(RDW) <b>NEW</b>	87
CL003GD115(RDB) <b>NEW</b>	87
CL003GZ09(ZB) <b>NEW</b>	87
CL003GZ14(ZW) <b>NEW</b>	87
CL100DW / DZX	89
CL102DW / DWX	89
CL104DWR / DWY / DWYX	89
CL105DWR / DWX	89
CL106FDSA / FDZ	88
CL107FDSA / FDZW / FDZ / FDSA	89
CL108FDSA / FDZ / FDZW	89
CL117FDX2 <b>NEW</b>	89
CL121DSAX1 / DSA / DZ	87
CLX224SAX1	126
CP100DSA / DZ	100
CS002GZ <b>NEW</b>	49
CW001GZ <b>NEW</b>	104
CW002GZ <b>NEW</b>	104
CW003GZ <b>NEW</b>	104
D	
DA3010F	23
DA330DWE	23
DA331DWE	23
DA332DZ	22
DA333DSAE / DZ	22
DBO180Z	77
DBO380RTJ / Z <b>NEW</b>	79
DBO481RTJ / Z <b>NEW</b>	80
DBS180Z	80
DCC500RTE / Z	47
DCE090ZX2 / Z	92
DCF102ZX1	103
DCF203Z	103
DCF301Z <b>NEW</b>	103
DCG180ZB / Z / ZK	99
DCL180FZW / FRGW / FZW1	88
DCL180Z / ZB / RTB	88
DCL181FZW / FZW1	88
DCL182ZB / ZW	88
DCL184Z	87
DCL280FZB / FZW / BX12 / FZW1	88
DCL281FZB / FZW	88
DCL282FRAW / FZW	88
DCMS01Z	104
DCO181Z	74
DCS552Z	49
DCS553Z	49
DCU180Z	116
DCW180Z	104
DDA351Z	22
DDF083RFE / Z	21



D	
DDF453RYE	21
DDF458RTE / RFE / Z	20
DDF482RTE / RFE / RFX1 / Z	20
DDF484RTE / RTX6 / RFE / Z	20
DDF486RTE / RFE / Z	20
DDF487RFJ / Z	21
DDG460ZX4	125
DF001DW	22
DF001GM201(RM2J) / GD201(RD2J) / GZ	20
DF002GD201(RD2J) / GA201(SA2J) / GZ	20
DF012DSE	22
DF0300	22
DF030DWE	22
DF032DSAE / DZ	21
DF033DSAE / DWYE / DZ	22
DF330DWE	21
DF332DSAE / DZ	21
DF333DSAE / DWYE / DZ	21
DF488D002 / D004 / DYEX4 <b>NEW</b>	21
DFL020FZ	129
DFL061FZ	129
DFL063FZ	129
DFL082FZ	129
DFL083FZ	130
DFL122FZ	130
DFL125FZ	130
DFL201FZ	130
DFL202FZ	130
DFL204FZ	130
DFL301FZ	130
DFL302FZ	130
DFL402FZ	130
DFL403FZ	130
DFL650FZ	130
DFN350ZJ	97
DFS251RTE	33
DFT023FNZ	128
DFT024FNZ	128
DFT025FNZ	129
DFT045FNZ	128
DFT060FNZ	129
DFT060TNZ <b>NEW</b>	129
DFT085FNZ	129
DFT120TNZ <b>NEW</b>	129
DFT126FZ	129
DFT127FNZ	129
DG001GZ02	125
DGA406RTE / RFE / Z	59
DGA408RTJ1 / Z	58
DGA413RTE / Z	58
DGA417RTE / Z	58
DGA419RTJ / Z	58
DGA506RTE / RFE / Z	58
DGA508RTE / RFE / Z	57
DGA513RTE / Z	58
DGA517RTE / Z	57
DGA519RTJ / Z	57
DGA700ZX1	57
DGA701Z	57
DGA900ZX1	57
DGA901Z	56
DGD800Z	63
DGP180Z	98
DHG180ZK <b>NEW</b>	94
DHG181ZK <b>NEW</b>	94
DHK180RTJ / Z	42
DHP453RFX4 / RYE	25
DHP482RTE / RFX1 / RFE / Z	25
DHP484RTE / RFE / Z	25

D	
DHP486RTE / RFE / Z	24
DHP487RFJ / Z	25
DHR171RTJ / Z	39
DHR182RGJ / RFJ / Z	39
DHR202RTE / Z	39
DHR242RTE / Z	39
DHR280PG2J / PF2J / ZJ	38
DHR281PG2J / ZJ	38
DHR282PG2J / ZJ	38
DHR283PG2J / ZJ	38
DHR400G2N / ZKN	37
DHS660RGJ / Z	70
DHS661RGJ / Z	70
DHS710Z	70
DHS782Z	69
DHS783Z	69
DHS900Z	69
DHW080ZK	93
DJN161Z	53
DJR183RTE / Z	46
DJR186RTE / ZK	45
DJR187RTE / ZK	45
DJR188RTJ / Z	46
DJR189RTE / Z <b>NEW</b>	46
DJR360PT2 / Z	45
DJS101Z	52
DJS130Z	52
DJS161Z	52
DJV180RTE / Z	72
DJV182RTE / Z	72
DJV184RTJ / Z <b>NEW</b>	72
DKP181Z	73
DKT360Z <b>NEW</b>	105
DLM230RG / Z <b>NEW</b>	123
DLM330RG / Z <b>NEW</b>	123
DLM382CF2 / Z	123
DLM432Z	123
DLM460Z	122
DLM462Z	122
DLM480Z <b>NEW</b>	122
DLM481Z <b>NEW</b>	122
DLM530Z	122
DLM532Z	122
DLM533Z	122
DLM538Z <b>NEW</b>	122
DLM539Z <b>NEW</b>	122
DLS211Z	66
DLS600Z	66
DLS714PT2 / Z	66
DLW140Z	52
DLX2051S <b>NEW</b>	126
DLX2131JX7 <b>NEW</b>	126
DLX2414JX3	126
DLX2424JX1	126
DMC300RTJ / Z <b>NEW</b>	47
DML185	109
DML801	110
DML805	107
DML806	110
DML807	110
DML808	109
DML809	107
DML810	108
DML811	107
DML812	109
DML813	108
DML814	108
DML815	109
DML816 <b>NEW</b>	110
DMP180Z	100
DMP181Z <b>NEW</b>	100

D	
DMR055 <b>NEW</b>	106
DMR108	106
DMR202	106
DMR203	106
DMR300	106
DP2010	23
DP4002/B	23
DP4700	24
DPB180Z	50
DPB182Z	50
DPB183Z	50
DPB184Z	50
DPJ180Z	74
DPO600RTE / Z	77
DPP200ZK	51
DPT353RTE / Z	95
DPV300RTJ / Z	78
DRC200Z	86
DRC300Z <b>NEW</b>	86
DRT50Z	75
DRV150Z	98
DRV250Z	98
DS4011	24
DSC121ZK	51
DSC163ZK	51
DSC191Z	51
DSC251ZK <b>NEW</b>	49
DSL800Z	76
DSL801Z <b>NEW</b>	76
DSP600Z	68
DSP601Z	68
DSS501RTE / Z	70
DSS610RTE / Z	70
DST121ZK	97
DST421ZK	97
DTD152RTE / RFE / Z	27
DTD153RTE / Z	27
DTD154RTE / Z	27
DTD156SYE / SF1J / Z	27
DTD157RTJ / Z <b>NEW</b>	27
DTD172RFJ / RTE / Z <b>NEW</b>	27
DTDA040Z	131
DTDA070Z	131
DTDA100Z	131
DTDA140Z	131
DTL061Z	28
DTL063Z	32
DTM51Z	99
DTM52RTJX2 / Z	99
DTR181Z <b>NEW</b>	98
DTS141RTE / Z	28
DTW1001JX2 / Z	29
DTW1002JX2 / Z	30
DTW180RFE / Z	31
DTW181ZK	30
DTW190RFE / Z	31
DTW251RTE / Z	30
DTW300RTJ / RFJ / Z	30
DTW450RTE / Z	30
DTW700RTJ / RFJ / Z	30
DTW800RMJ	30
DTWA070Z	132
DTWA100Z	132
DTWA140Z	132
DTWA190Z	132
DUA300ZB	115
DUA301ZB	115
DUB184Z	82
DUB185Z	83
DUB186Z	82
DUB361Z	81

D	
DUB362Z	81
DUB363ZV / PG2V	81
DUC254Z	114
DUC302Z	114
DUC306ZB	114
DUC353ZB	114
DUC355Z	114
DUC357ZX4 <b>NEW</b>	114
DUH502Z	117
DUH506Z <b>NEW</b>	117
DUH523RF / SF / Z	117
DUH601Z	117
DUH604SZ	116
DUH606Z <b>NEW</b>	116
DUH651Z	117
DUH751Z	117
DUH754SZ	116
DUM111SYX	118
DUM604SF / Z	118
DUN461WSF / WZ	118
DUN500WZ	118
DUN600LZ	117
DUP361PT2N / ZN	124
DUP362PT2N / ZN	124
DUR181RF / SF / Z	120
DUR189Z <b>NEW</b>	120
DUR190LZX3	120
DUR193SF / Z <b>NEW</b>	120
DUR194SF2 / ZX3 <b>NEW</b>	120
DUR365UZ	120
DUR368LZ	120
DUR369LZ	119
DUS054Z	124
DUS108Z <b>NEW</b>	124
DUS158Z <b>NEW</b>	124
DUT130RTE / Z	34
DUX18Z	113
DUX60Z	112
DVC150LZ	83
DVC151LZ	84
DVC153LZ	84
DVC154LZ	84
DVC155LZX2	84
DVC261ZX17	86
DVC265ZX6U	86
DVC350Z	89
DVC560PG2 / Z	84
DVC660ZX7	85
DVC665Z	85
DVC750LZX1	86
DVC860LZ	84
DVC865LZX2	84
DVC867LZX4	84
DVF104Z	124
DVF154Z	124
DVP180Z	99
DVP181ZK <b>NEW</b>	99
DWR180RF / Z	32
DWT310PG2 / ZK	32
E	
ELM3320	123
ELM3720	123
ELM4121	123
ELM4620	123
F	
FN001GD101(RDK) / GZ	96
FS2500	33
FS2700	33
FS4300	33
G	
GA003GM201(RM2J) /	56



<b>G</b>	
GD201(RD2J) / GZ	
GA004GM201(RM2J) / GD201(RD2J) / GZ	56
GA005GM201(RM2J) / GD201(RD2J) / GZ	56
GA011GM201(RM2J) / GD201(RD2J) / GZ	56
GA012GM201(RM2J) / GD201(RD2J) / GZ	55
GA013GM201(RM2J) / GD201(RD2J) / GZ	54
GA021GM201(RM2J) / GD201(RD2J) / GZ	56
GA022GM201(RM2J) / GD201(RD2J) / GZ	55
GA023GM201(RM2J) / GD201(RD2J) / GZ	55
GA027GM201(RM2J) / GD201(RD2J) / GZ	55
GA028GM201(RM2J) / GD201(RD2J) / GZ	55
GA029GM201(RM2J) / GD201(RD2J) / GZ	54
GA035GZ	54
GA036GZ	54
GA037GZ	54
GA038GZ	54
GA042GM201(RM2J) / GD201(RD2J) / GZ <b>NEW</b>	55
GA044GM201(RM2J) / GD201(RD2J) / GZ <b>NEW</b>	54
GA4030	59
GA4031	59
GA4034	60
GA4040	59
GA4040C	60
GA4041C	60
GA4050R	59
GA4530	61
GA4550R	61
GA5010	61
GA5010/B	61
GA5030	61
GA5034	61
GA5040CZ	61
GA5050R	62
GA5080R	62
GA6010	62
GA6010X3/B	62
GA6020C <b>NEW</b>	62
GA7020	62
GA7060	62
GA7060R/B	62
GA7061R	62
GA7070X1 <b>NEW</b>	63
GA7070X1/B <b>NEW</b>	63
GA7081 <b>NEW</b>	63
GA9020	63
GA9060	63
GA9070X1 <b>NEW</b>	63
GA9081 <b>NEW</b>	63
GB602	64
GB801	64
GD0600	64
GD0600/B	64
GD0601	64
GD0602	64
GD0603	64
GD0603/B	64
GD0800C	64
GD0800C/B	64

<b>G</b>	
GS5000	64
GV6010	79
<b>H</b>	
HB350 <b>NEW</b>	35
HB500	35
HB500/B	35
HG5030	94
HG6030K	94
HG6031VK	95
HG6530VK	95
HG6531CK <b>NEW</b>	95
HK1820	42
HM001GM204(RM2K) / GZ03(K)	42
HM002GZ03(K)	42
HM0810A	43
HM0810TA	43
HM0810TA/B	43
HM0870C	43
HM0870C/B	43
HM0871C	43
HM1205C	44
HM1213C	44
HM1214C	44
HM1214C/B	44
HM1306	44
HM1306/B	44
HM1501	44
HM1511	44
HM1812	44
HM1812/B	44
HP001GM201(RM2J) / GD201(RD2J) / GZ	24
HP002GD201(RD2J) / GA201(SA2J) / GZ	24
HP0300	26
HP1630	26
HP1630/B	26
HP2050	26
HP2070	26
HP330DWE	25
HP332DSAE / DZ	25
HP333DSAE / DWYE / DWYX3 / DYEX4 / DZ	25
HP488D002 / D006 <b>NEW</b>	25
HR001GM201(RM2J) / GD201(RD2J) / GZ	36
HR002GM201(RM2J) / GD201(RD2J) / GZ	36
HR003GM201(RM2J) / GD201(RD2J) / GZ	37
HR004GM201(RM2J) / GZ	37
HR005GM201(RM2K) / GZ(K)	36
HR006GZ(K)	36
HR007GM201(RM2J) / GZ <b>NEW</b>	37
HR008GM201(RM2K) / GZ <b>NEW</b>	36
HR009GM201(RM2K) / GZ <b>NEW</b>	36
HR166DSAE1 / DZ	39
HR1840J	39
HR2020	39
HR2300	39
HR2300/B	40
HR2470X5	40
HR2470X5/B	40
HR2600	40
HR2630/B	40
HR2630X3	40
HR2652X3 <b>NEW</b>	40
HR2810	40
HR2810/B	40
HR3001CJ	40
HR3011FCJ	41

<b>H</b>	
HR3200C	41
HR4003C	41
HR4003C/B	41
HR4013C	41
HR4501C	41
HR5202C	41
HR5202C/B	41
HR5212C	41
HS003GM201(RM2) / GZ	69
HS004GM201(RM2) / GZ	69
HS009GZ <b>NEW</b>	69
HS010GZ <b>NEW</b>	69
HS0600	71
HS300DW / DZ	70
HS301DWAE / DZ	70
HS6600	71
HS7010	71
HS7600	71
HW102	93
HW132	94
HW151	94
<b>J</b>	
JN1601	53
JN3201J	53
JR001GM201(RM2J) / GD201(RD2J) / GZ	45
JR002GM201(RM2J) / GD201(RD2J) / GZ <b>NEW</b>	45
JR103DWYE	46
JR3051TK	46
JR3061T	46
JR3070CT	46
JR3070CT/B	46
JS1300	53
JS1601	53
JS1602	53
JS3201J	53
JV0600K	73
JV101DSAE / DZ	72
JV103DSAJ / DZ	72
<b>K</b>	
KP001GZ <b>NEW</b>	73
KP0800X	73
KT001GZ <b>NEW</b>	105
<b>L</b>	
LB1200F	68
LC1230	50
LC1230/B	50
LCT204	126
LD030P	102
LD050P	102
LD080P	102
LH1201FL	67
LM001CZ	121
LM001JM101 <b>NEW</b>	121
LM002JM101 <b>NEW</b>	121
LS002GZ	66
LS003GZ <b>NEW</b>	65
LS004GZ <b>NEW</b>	65
LS0714	66
LS1018L	66
LS1019L	66
LS1040	67
LS1040/B	67
LS1219L	66
LS1440	67
LW1401	52
LW1401/B	52
<b>M</b>	
M0600B	133
M0801B	134

<b>M</b>	
M0900B	135
M0910B	135
M0920B	136
M0921B	136
M1100KB	138
M1902B	138
M2300B	136
M2401B	134
M3600B	137
M3601B	137
M3602B <b>NEW</b>	137
M3700B	137
M3702B <b>NEW</b>	137
M4000B	138
M4001B	138
M4100B	134
M4301B	136
M4302B	137
M4500B	137
M5801B	136
M6001B	133
M6500B	133
M6600XB	133
M8100B	134
M8103B	133
M8103KX2B	133
M8600B	134
M8700B	134
M8701B	134
M9002B	136
M9100B	136
M9200B	138
M9203B	138
M9204B	138
M9400B	138
M9506B	135
M9508B	135
M9509B	135
M9510B	135
M9511B	136
M9512B	135
M9513B	135
ML001G	109
ML002G	110
ML003G <b>NEW</b>	107
ML005G <b>NEW</b>	107
ML006G <b>NEW</b>	110
ML007G <b>NEW</b>	109
ML009G <b>NEW</b>	107
ML103	110
ML104	110
ML105	109
ML106	109
MLT100	67
MP001GZ <b>NEW</b>	100
MP100DZ	100
MR002G	106
MR006G <b>NEW</b>	105
<b>N</b>	
N1900B	73
N3701	75
N5900B	71
<b>P</b>	
PB002GM201(RM2K) / GZ <b>NEW</b>	50
PC5000C/B	48
PC5010C	48
PC5010C/B	48
PDC01 (191A62-6 / 191A67-6)	19
PDC1200A01 / A02	19
PJ7000	74
PO6000C	77



P	
PT001GD201(RD2K) / GZ <b>NEW</b>	95
PT354DSAJ / DZ	96
PV001GM101(RMX) / GZ <b>NEW</b>	78
PV301DSAE / DZ	78
PV7000C	79
PW5001C	48
R	
RP0900	75
RP1800	75
RP1801	75
RP2300FC	76
RT001GM202(RM2J) / GZ04 <b>NEW</b>	74
RT0700C / CX2	75
S	
SC103DZ	51
SG1251J	47
SJ401	67
SK10GDZ <b>NEW</b>	102
SK105GDZ	102
SK20GDZ <b>NEW</b>	102
SK209GDZ	101
SK312GDZ	101
SK40GDZ <b>NEW</b>	102
SK700GD / D <b>NEW</b>	102
SP001GZ <b>NEW</b>	68
SP6000J	68
T	
TB131	35
TD001GM201(RM2J) / GD201(RD2J) / GZ	26
TD003GA201(SA2J) / GZ <b>NEW</b>	26
TD0101F	28
TD022DSE	28
TD043DNZ	131
TD044DNZ	131
TD063DNZ	131
TD090DWE	28
TD091DWE	132
TD110DSAE / DWYE / DZ	28
TD111DSAE / DZ	28
TD112DNZ <b>NEW</b>	131
TL064DZ	28
TL065DZ	32
TM3010CX6	100
TW001GM204(RM2JX) / GD203(RD2JX) / GD201(RD2J) / GZ	29
TW004GM202(RM2J) / GD201(RD2J) / GZ	29
TW007GM201(RM2J) / GD201(RD2J) / GZ	29
TW0200	31
TW0350	31
TW0350/B	32
TW060DSAE / DZ	31
TW1000	32
TW1000/B	32
TW140DSAE	31
TW141DSAE / DZ	31
TW160DSAE / DSME / DZ	31
U	
UA001GM102(RM) / GZ01 <b>NEW</b>	115
UA002GM102(RM) / GZ01 <b>NEW</b>	115
UB001CZ	81
UB001GM201(RMX) / GZ	81
UB002CZ01 <b>NEW</b>	81
UB100DZ	83
UB101DZ	82
UB1102	83
UB1103	83
UB1103/B	83
UC003GZ01 <b>NEW</b>	113

U	
UC012GT101(RT) / GZ <b>NEW</b>	114
UC014GT101(RT) / GZ <b>NEW</b>	114
UC015GT101(RT) / GZ <b>NEW</b>	114
UC3541A	115
UC3551A	115
UC4041A	115
UC4051A	115
UC4551A	115
UH006GZ	116
UH014GM101(RM) / GZ <b>NEW</b>	116
UH201DSAX / DWA / DZ	118
UH353DSA / DWA / DZ	117
UM600DSYEX / DWA / DZ	119
UN460WDWA / WDZ	118
UR003GZ <b>NEW</b>	119
UR008GM101(RM) / GZ01 <b>NEW</b>	119
UR012GZ204 <b>NEW</b>	119
UR100DWA / DZ	120
UR202CZ	119
UR3000	121
US053DZ	124
UT1301	34
UT1305	35
UT1305/B	35
UT2204/B	35
UX01GZ	112
V	
VC003GLZ <b>NEW</b>	83
VC004GLZ <b>NEW</b>	83
VC008GZ04 <b>NEW</b>	85
VC009GZ <b>NEW</b>	85
VC2000L	87
VC2510L	87
VC3210L	87
VC3210L/B	87
W	
WR100DSAEK / DZ	32





## Safety Precautions

When using electric tools, basic safety precautions should always be followed to reduce the risk of fire, electric shock, and personal injury, including the following.

### /// KEEP WORK AREA CLEAN.

Cluttered areas and benches invite injuries.

### /// CONSIDER WORK AREA ENVIRONMENT.

Don't use power tools in damp or wet locations. Keep work area well lit. Don't expose power tools to rain. Don't use power tool in presence of flammable liquids or gases.

### /// KEEP CHILDREN AWAY.

All visitors should be kept away from work area. Don't let visitors touch the tool or extension cord.

### /// STORE IDLE TOOLS.

When not in use, tools should be stored in a dry, high of locked up place, out of reach of children.

### /// DON'T FORCE THE TOOL.

It will do the job better and safer at the rate for which it was intended.

### /// USE THE RIGHT TOOL.

Don't force small tools or attachments to do the job of a heavy-duty tool. Don't use tools for purposes not intended.

### /// DRESS PROPERLY.

Don't wear loose clothing or jewelry. They can be caught in moving parts. Rubber gloves and non-skid footwear are recommended when working outdoors. Wear protective hair covering to contain long hair.

### /// USE SAFETY GLASSES.

Also use face or dust mask if the cutting operation is dusty.

### /// DON'T ABUSE THE CORD.

Never carry the tool by the cord or yank it to disconnect it from the socket. Keep the cord away from heat, oil, and sharp edges.

### /// SECURE WORK.

Use clamps or a vise to hold the work. It's safer than using your hand and it frees both hands to operate the tool.

### /// DON'T OVERREACH.

Keep proper footing and balance at all times.

### /// MAINTAIN TOOLS WITH CARE.

Keep cutting tools sharp and clean for better and safer performance. Follow instructions for lubrication and changing accessories. Inspect tool cord periodically and if damaged, have it repaired by an authorized service facility. Inspect extension cords periodically and replace, if damaged. Keep handles dry, clean and free from oil and grease.

### /// DISCONNECT TOOLS.

When not in use, before servicing and when changing accessories such as blades, bits and cutters.

### /// REMOVE ADJUSTING KEYS AND WRENCHES.

Form the habit of checking to see that keys and adjusting wrenches are removed from the tool before turning it on.

### /// AVOID UNINTENTIONAL STARTING.

Don't carry a plugged-in tool with a finger on the switch. Ensure switch is OFF when plugging in.

### /// USE OUTDOOR EXTENSION CORDS.

When tool is used outdoors, use only extension cords intended for outdoor use.

### /// STAY ALERT.

Watch what you are doing. Use common sense. Don't operate tool when you are tired.

### /// CHECK DAMAGED PARTS.

Before further use of the tool, a guard or other part that is damaged should be carefully checked to determine that it will operate properly and perform its intended function. Check for alignment of moving parts, free running of moving parts, breakage of parts, mounting and any other conditions that may affect its operation. A guard or other part that is damaged should be properly repaired or replaced by an authorized service center unless otherwise indicated in this instruction manual. Have defective switches replaced by an authorized service facility. Don't use the tool if the switch does not turn it on and off.

### /// GUARD AGAINST ELECTRIC SHOCK.

Avoid body contact with earthed or grounded surfaces (e.g. pipes, radiators, ranges, refrigerators).

### /// REPLACEMENT PARTS.

When servicing a tool, use only identical replacement parts.

### /// VOLTAGE WARNING:

Before connecting the tool to a power source (receptacle, outlet, etc.) Be sure the voltage supplied is the same as that specified on the nameplate of the tool. A power source with voltage greater than that specified for the tool can result in SERIOUS INJURY to the user V as well as damage to the tool. If in doubt, DO NOT PLUG IN THE TOOL. Using a power source with voltage less than the nameplate rating is harmful to the motor.

## Note

- Makita reserves the right to change specifications of parts and accessories without notice.
- Items of standard equipment and specifications may vary by country or area.
- Net weight and dimensions may differ by the type of battery.
- Standard export color for motor housing is Makita industrial green (blue).
- Please state required voltage when ordering. These offers are subject to availability in each country. Actual product color may differ slightly from color reproduced here.
- Weight data in this catalogue is the value measured by us according to EPTA Procedure 01/ 2003.

## Warranty

Every **MAKITA** tool is thoroughly inspected and tested before leaving the factory. Subject to the following Terms and Conditions from the date of purchase, this tool is warranty against **defective materials and manufacturing defects**.

### The period and conditions of our warranty as follows:

1. Sales receipt must be presented when servicing or warranty is required.
2. Warranty **ONLY** cover tools distributed by Makita Singapore Pte. Ltd. Warranty does not cover tools purchased overseas or distributed by other countries.
3. **This warranty is valid base on the original purchase receipt with "Date of Purchase", "Model Number" & "Serial Number".**

### This warranty will be null & void in any of the following events during the warranty period:

1. The product unit has undergone repair, attempted repair, dismantle or modification in any way whatsoever by any other person.
2. Damage resulting from use of improper accessories, non-genuine replacement parts, disassembly, tampering, alternation and repairing in any way that affects the reliability and performance.
3. Damage resulting from negligence, accident, disaster, improper storage or maintenance, abuse and misuse in evident caused by overloading the tool beyond its capacity.
4. Abnormal voltage or usage of generator, wrong usage not in accordance with the Operation Manual.
5. If the Serial Number on the tool, seal on the battery and charger has been defaced or removed.
6. If any information on the warranty card has been defaced, removed, altered, unreadable or unclear (date of purchase, Serial Number, etc.)

\*\* Makita reserved the rights of amend conditions of warranty without prior notice.

Please visit our website for Makita's Service Centre information

<http://www.makita.com.sg/servicing-the-customer>



**Tool ◀▶ Battery ◀▶ Battery Charger**  
**Digital communication**

**XGT is a new system with its own tools, batteries, and chargers. A combination of innovative tool design and higher output batteries provide a genuine solution for high demand industrial users.**

**Optimum power supply system and Optimum charging system**

The XGT range of tools and batteries come with a built-in program, providing digital communication between the battery and tool. Allowing not only for the battery to talk with tool but also the tool to talk to the battery. Battery technology and motor engineering that work together for optimum performance.

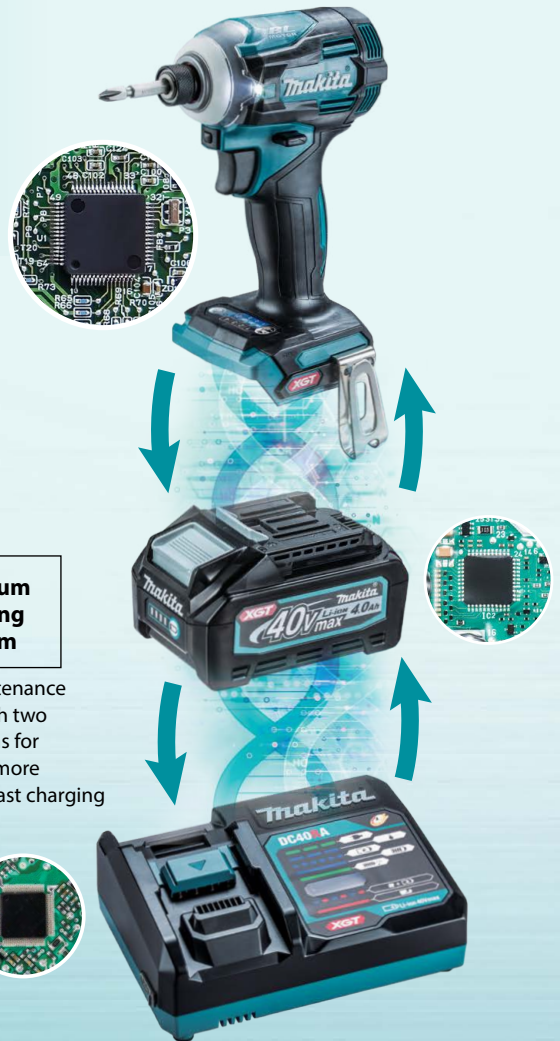

**Optimum charging system**

Auto maintenance system with two cooling fans for providing more optimum fast charging

**Built Tough**

High durability specifications specially designed for 40Vmax Li-Ion batteries

**4-LED fuel gauge indicator**

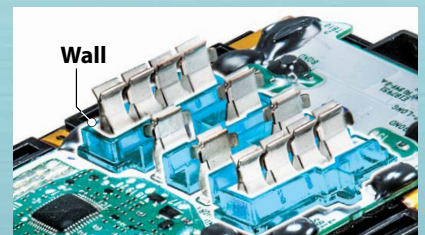
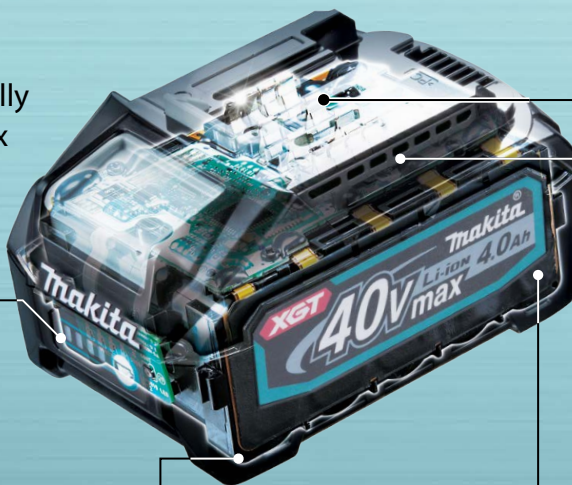

**Terminal short-circuit prevention structure**  
The protection wall is provided between terminals against water and dust.

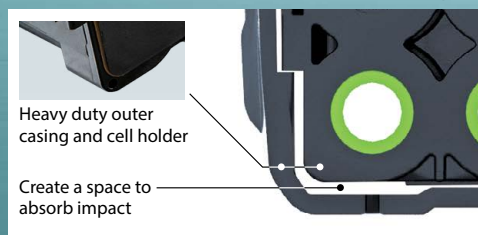

**Shock absorption structure**

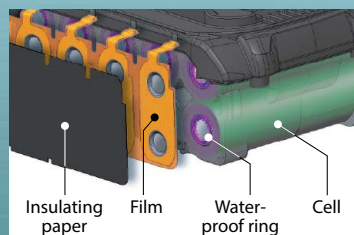

**Waterproof Triple-layer Structure**  
prevents cell failure due to water and dust.

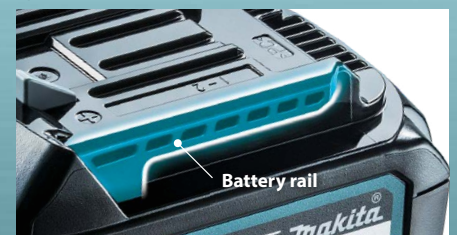

**High Rigidity Battery Rails**  
Durable slide in battery rail that holds the battery and the tools firmly and securely to withstand high power products



## 40Vmax mechanism movie

This movie was filmed in Japan.  
Models and specs may vary by country.



## Rapid Optimum Charging System

It is necessary to cool down before start charging when the battery temperature is high.  
Built-in fan circulates air through the battery before start charging and during the charging process to cool the battery for faster charge time.

The Makita Rapid Optimum Charger communicates with the battery's built-in chip throughout the charging process to optimize battery life by actively controlling current, voltage and temperature.

The optimum charging system  
Forced air cooling



Fast charging



General charging method  
Natural heat dissipation

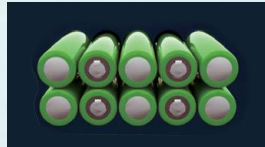

Waiting time for charging

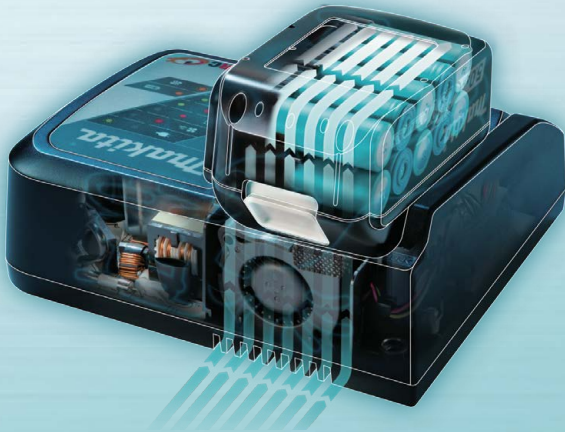
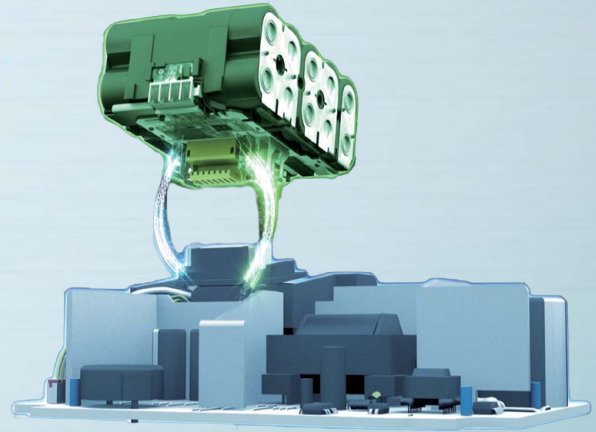

The optimum charging system

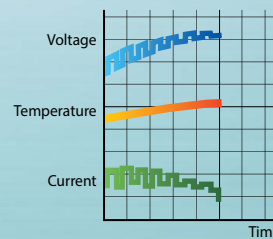

General charging method

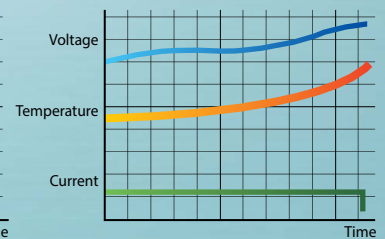

## Battery Protection Function

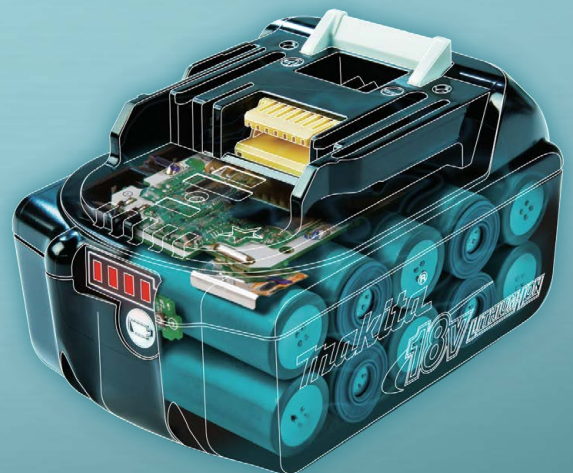
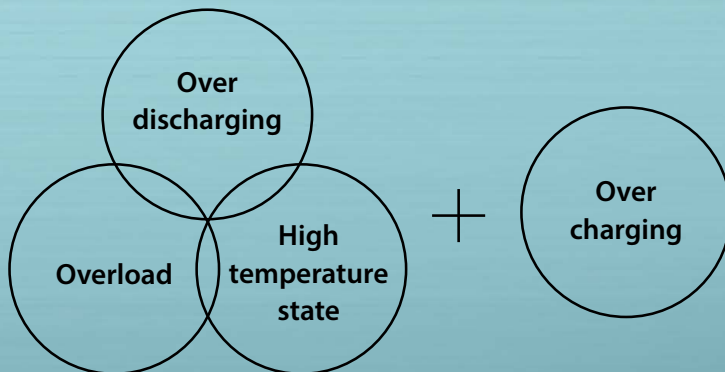

This function is communication technology that allows the tool and battery to monitor conditions and exchange data in real time to protect against Overload, Over-Discharge and Overheating.

## Firm Holding

Multi-contact terminals reduce electrical resistance and increase connection stability withstanding against vibration, and ultimately ensures Stable current supply to the tool.

**Anytime Charge**  
No Memory Effect  
No discharging required



**Shock Absorbing**  
Heavy Duty Pack

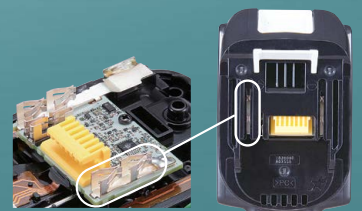

# Li-ion Battery & Charger Time Reference, Compatibility Chart

40Vmax		18V		Fast Charging DC40RA (191E08-6)	DC40RC (191M92-9)	Fast Charging DC40RA + ADP10 (191C11-5) Compatible with LXT Li-Ion batteries	DC40RC + ADP10 (191C11-5) Compatible with LXT Li-Ion batteries	Fast Charging DC18RC (195586-8) 110V - (195582-6)	DC18SD (194534-4)
40Vmax Lithium-ion <b>XGT</b>	8.0Ah BL4080F (191X65-8)	76min.	170min.	-	-	-	-	-	-
	5.0Ah BL4050F (191L47-8)	50min.	85min.	-	-	-	-	-	-
	4.0Ah BL4040 (191B26-6)	45min.	67min.	-	-	-	-	-	-
	2.5Ah BL4025 (191B36-3)	28min.	38min.	-	-	-	-	-	-
	2.0Ah BL4020 (191L29-0)	22min.	30min.	-	-	-	-	-	-
	6.0Ah BL1860B (197422-4)	-	-	40min.	85min.	55min.	130min.	-	-
18V Lithium-ion <b>LXT</b>	5.0Ah BL1850B (197280-8)	-	-	35min.	70min.	45min.	110min.	-	-
	4.0Ah BL1840B (197265-4)	-	-	29min.	58min.	36min.	90min.	-	-
	3.0Ah BL1830B (197599-5)	-	-	22min.	42min.	22min.	60min.	-	-
	2.0Ah BL1820B (197254-9)	-	-	24min.	33min.	24min.	45min.	-	-
	1.5Ah BL1815N (196449-1)	-	-	15min.	22min.	15min.	30min.	-	-
12Vmax Lithium-ion <b>CXT</b>	4.0Ah BL1041B (197406-2)	60min.	130min.	40Vmax Lithium-ion		360min.	40Vmax Lithium-ion 18V x2 Lithium-ion 18V Lithium-ion		Powered by up to four 18V LXT Batteries
	2.0Ah BL1021B (197396-9)	30min.	70min.	18V x2 Lithium-ion					
	1.5Ah BL1016 (197393-5)	22min.	50min.						
64Vmax Lithium-ion	4.0Ah BL6440 (191R06-8)	120min.	10.8V Lithium-ion	1.3Ah BL1013 (196066-7)	50min.	18V Lithium-ion	1.5Ah BL1815G   BL1415G (198186-3)   (198192-8)	70min.	
			7.2V Lithium-ion	1.5Ah BL0715 (198000-3)	35min.	14.4V Lithium-ion	2.0Ah BL1820G (197254-9)	90min.	

\* DC40RB / DC18RD / DC18SH: Two Port Multi Fast Charger \*\* DC18RE: CXT & LXT Dual port Fast Charger



## MAKPAC Power Source Kit



<b>QADPSKG1</b> (191V23-2)	Fast Charger (DC40RC), 2X40Vmax - 2.0Ah Batteries (BL4020), Makpac	
<b>QAEPSKG1</b> (191V31-3)	Fast Charger (DC40RC), 2X40Vmax - 2.5Ah Batteries (BL4025), Makpac	
<b>MKP1G001</b> (191J85-8)	Rapid Charger (DC40RA), 2X40Vmax - 2.5Ah Batteries (BL4025), Makpac	
<b>MKP1G002</b> (191K01-6)	Rapid Charger (DC40RA), 2X40Vmax - 4.0Ah Batteries (BL4040), Makpac	
<b>MKPPSKG2</b> (191V42-8)	Rapid Charger (DC40RA), 2X40Vmax - 5.0Ah Batteries (BL4050F), Makpac	
<b>QAAPSKG3</b> (191U06-6)	Dual Port Multi Rapid Charger (DC40RB), 2X40Vmax - 4.0Ah Batteries (BL4040), Makpac	
<b>QABPSKG3</b> (191U20-2)	Dual Port Multi Rapid Charger (DC40RB), 2X40Vmax - 5.0Ah Batteries (BL4050F), Makpac	
<b>QAPSKG3</b> (1910A2-5)	Dual Port Multi Rapid Charger (DC40RB), 2X40Vmax - 8.0Ah Batteries (BL4080F), Makpac	
<b>QACPSKG3</b> (191U34-1)	Dual Port Multi Rapid Charger (DC40RB), 4X40Vmax - 4.0Ah Batteries (BL4040), Makpac	
<b>QADPSKG3</b> (191U48-0)	Dual Port Multi Rapid Charger (DC40RB), 4X40Vmax - 5.0Ah Batteries (BL4050F), Makpac	

## MAKPAC Power Source Kit



<b>MKP1RF182</b> (197974-5)	Rapid Charger (DC18RC), 2X18V - 3.0Ah Batteries (BL1830B), Makpac	
<b>MKP1RM182</b> (191L71-1)	Rapid Charger (DC18RC), 2X18V - 4.0Ah Batteries (BL1840B), Makpac	
<b>MKP1RT182</b> (197803-2)	Rapid Charger (DC18RC), 2X18V - 5.0Ah Batteries (BL1850B), Makpac	
<b>MKP1RG182</b> (198119-8)	Rapid Charger (DC18RC), 2X18V - 6.0Ah Batteries (BL1860B), Makpac	
<b>MKP3PT182</b> (198182-1)	Dual Port Rapid Charger (DC18RD), 2X18V - 5.0Ah Batteries (BL1850B), Makpac	
<b>MKP3PG182</b> (198081-7)	Dual Port Rapid Charger (DC18RD), 2X18V - 6.0Ah Batteries (BL1860B), Makpac	
<b>MKP3PT184</b> (197627-6)	Dual Port Rapid Charger (DC18RD), 4X18V - 5.0Ah Batteries (BL1850B), Makpac	
<b>MKP3PG184</b> (198095-6)	Dual Port Rapid Charger (DC18RD), 4X18V - 6.0Ah Batteries (BL1860B), Makpac	

## MAKPAC Power Source Kit



<b>MKP1SY122</b> (197654-3)	Fast Charger (DC10SB), 2X12Vmax - 1.5Ah Batteries (BL1016), Makpac	
<b>MKP1SA122</b> (197664-0) (191K13-9)	Fast Charger (DC10SB), 2X12Vmax - 2.0Ah Batteries (BL1021B), Makpac	
<b>MKP1SM122</b> (197640-4) (191K12-1)	Fast Charger (DC10SB), 2X12Vmax - 4.0Ah Batteries (BL1041B), Makpac	

**XGT**

# 40V Li-ion max

High Power

Durability

Digital Communication



**XGT**  
40V Li-ion max

**XGT X2**  
80V max



Rotary Hammer



Demolition Hammer



Grass Trimmer



Power Cutter



Flashlight

Job Site Radio

Brad Nailer

Kettle

Inflator

Cooler & Warmer Box

Fan

Hedge Trimmer

Blower

Dust Blower

Earth Auger

Pole Saw

Grass Trimmer

Chain Saw

Multi Function Power Head

## Battery

BL4020  
2.0Ah

BL4025  
2.5Ah





Impact Driver



Driver Drill



Hammer Driver Drill



Rotary Hammer



Impact Wrench



Angle Drill



Polisher



Demolition Hammer



Rear Handle Saw



Combination Hammer



Angle Grinder



Circular Saw



Plunge Cut Saw



Slide Compound Miter Saw



Backpack Vacuum Cleaner



Recipro Saw



Metal Cutter



Cleaner



Planer



Portable Band Saw



Trimmer



Vacuum Cleaner



Charger

BL4040 4.0Ah



BL4050F 5.0Ah



BL4080F 8.0Ah



DC40RA



DC40RB



DC40RC



ADP10



Adapter for LXT Battery



# 18V LITHIUM-ION



18V Lithium-ion

# LXT

Vacuum Pump

Worklight

Fan Jacket

Fan Vest

Hedge Trimmer

Grass Trimmer

Cleaner

Cyclone Cleaner



Wheelbarrow



Heat Gun



Flashlight Radio



Flashlight



Area Worklight



LED Flashlight



Rebar Tying Tool



Rivet Gun



Hole Puncher



Grease Gun



Concrete Vibrator



Pin Nailer



Finish Nailer



Brad Nailer



Inflator



Fan



LED Worklight



Job Site Radio



Job Site Speaker



Heated Vest



Heated Blanket



Coffee Maker



Cooler & Warmer Box



Grass Shear



Blower



Robotic Cleaner



Trimmer

Recipro Saw



Garden Sprayer



Chain Saw



Vacuum Cleaner



Portable Vacuum Cleaner



Planer



Drywall Saw



String Trimmer

Multi Function Power Head



Belt Sander



Grass Trimmer

Grass Trimmer

Cut-Out Tool



Plate Joiner

Wall Scanner



Stapler



Slide Compound Miter Saw



Combination Hammer



Circular Saw



Plunge Cut Saw



Angle Grinder

Angle Drill



Shear Wrench



Angle Drill



Recipro Saw



Rear Handle Saw



Portable Cut-off



Power Cutter



Rotary Hammer

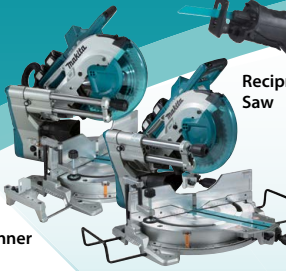

Miter Saw



Wall Scanner



Caulking Gun



Heat Gun



Vacuum Pump



Flashlight Radio



Rivet Gun



Hole Puncher



Grease Gun



Brad Nailer



Inflator



Fan



LED Worklight



Job Site Radio



Job Site Speaker



Heated Vest



Heated Blanket



Coffee Maker



Cooler & Warmer Box



Grass Shear



Blower



Robotic Cleaner



Trimmer

Recipro Saw



Garden Sprayer



Chain Saw



Vacuum Cleaner



Portable Vacuum Cleaner



Planer



Drywall Saw



String Trimmer

Multi Function Power Head



Belt Sander



Grass Trimmer

Grass Trimmer

Cut-Out Tool



Plate Joiner



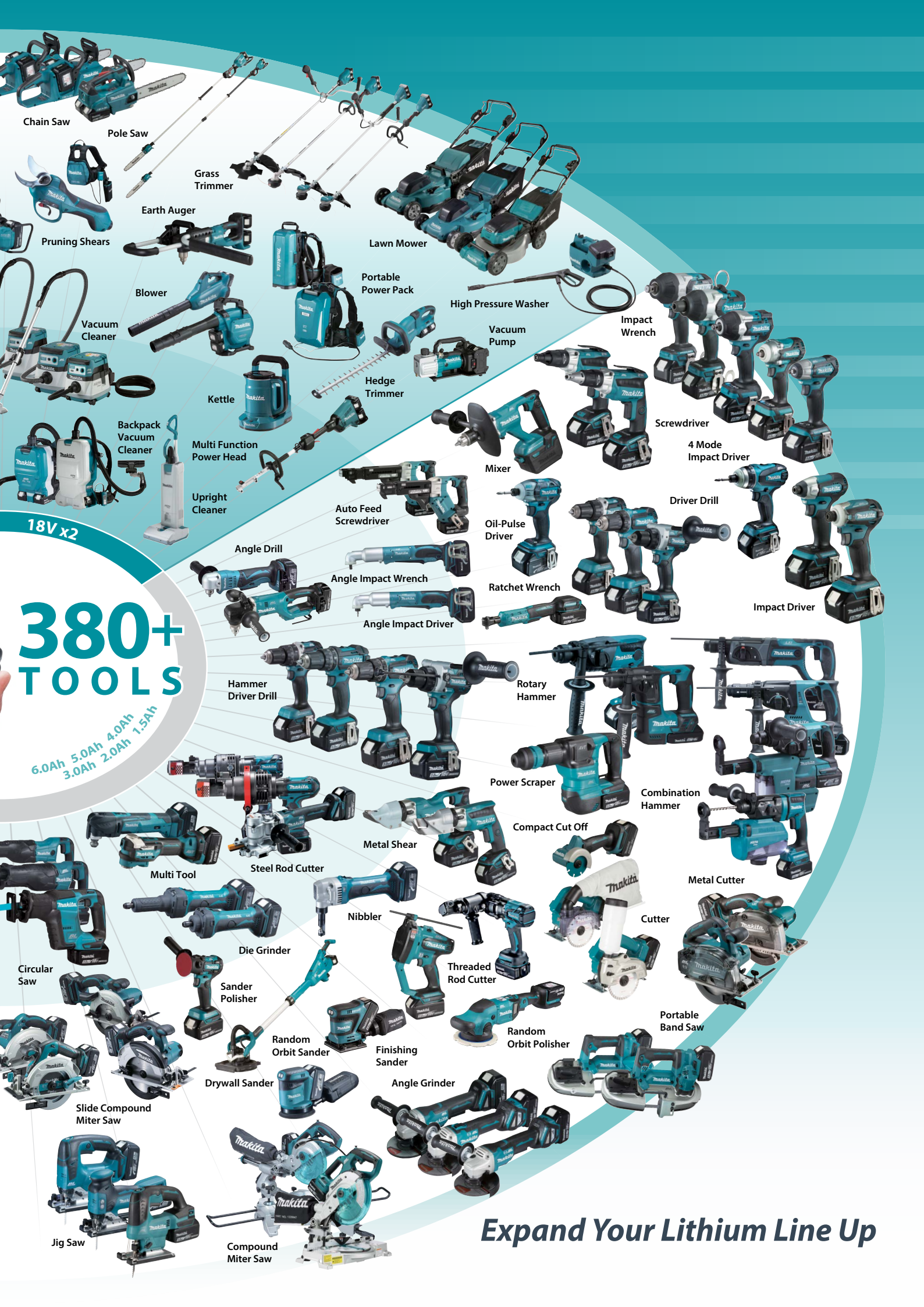

Chain Saw

Pole Saw

Grass Trimmer

Earth Auger

Pruning Shears

Lawn Mower

Blower

Portable Power Pack

High Pressure Washer

Vacuum Cleaner

Vacuum Pump

Impact Wrench

Backpack Vacuum Cleaner

Kettle

Hedge Trimmer

Screwdriver

Multi Function Power Head

Auto Feed Screwdriver

Mixer

4 Mode Impact Driver

Upright Cleaner

Oil-Pulse Driver

Driver Drill

18V x2

Angle Drill

Ratchet Wrench

Impact Driver

380+ TOOLS

6.0Ah 5.0Ah 4.0Ah 3.0Ah 2.0Ah 1.5Ah

Angle Drill

Angle Impact Wrench

Angle Impact Driver

Hammer Driver Drill

Rotary Hammer

Power Scraper

Combination Hammer

Multi Tool

Steel Rod Cutter

Metal Shear

Compact Cut Off

Metal Cutter

Circular Saw

Nibbler

Die Grinder

Threaded Rod Cutter

Cutter

Sander Polisher

Random Orbit Sander

Finishing Sander

Random Orbit Polisher

Portable Band Saw

Drywall Sander

Angle Grinder

Slide Compound Miter Saw

Jig Saw

Compound Miter Saw

Expand Your Lithium Line Up



# 12V<sub>max</sub> LITHIUM-ION

**EXPAND YOUR LITHIUM-ION LINEUP**

4.0Ah 2.0Ah 1.5Ah

- Driver Drill
- Hammer Driver Drill
- Impact Driver
- Angle Drill
- Impact Wrench
- Rotary Hammer
- Ratchet Wrench
- Circular Saw
- Angle Impact Driver
- Multi Cutter
- Threaded Rod Cutter
- Cutter
- Recipro Saw
- Drywall Saw
- Multi tool
- Jig Saw
- Pin Nail
- Stapler
- Sander Polisher
- Adapter for USB
- Caulking Gun
- Garden Sprayer
- Hedge Trimmer
- Inflator
- Blower
- Grass Trimmer
- Grass Shear
- LED Flashlight
- Fan
- Fan Jacket
- Fan Vest
- Heated Jacket
- Heated Vest
- Heated Blanket
- Rechargeable Green Multi Line Laser
- Rechargeable Red 4-point Cross Line Laser
- Job Site Radio
- Job Site Speaker
- Rechargeable Green Multi Line Laser
- Rechargeable Red 4-point Cross Line Laser





# 10.8V Lithium-ion



# 7.2V Lithium-ion



# A wide variety of Lithium-ion Garden Tools

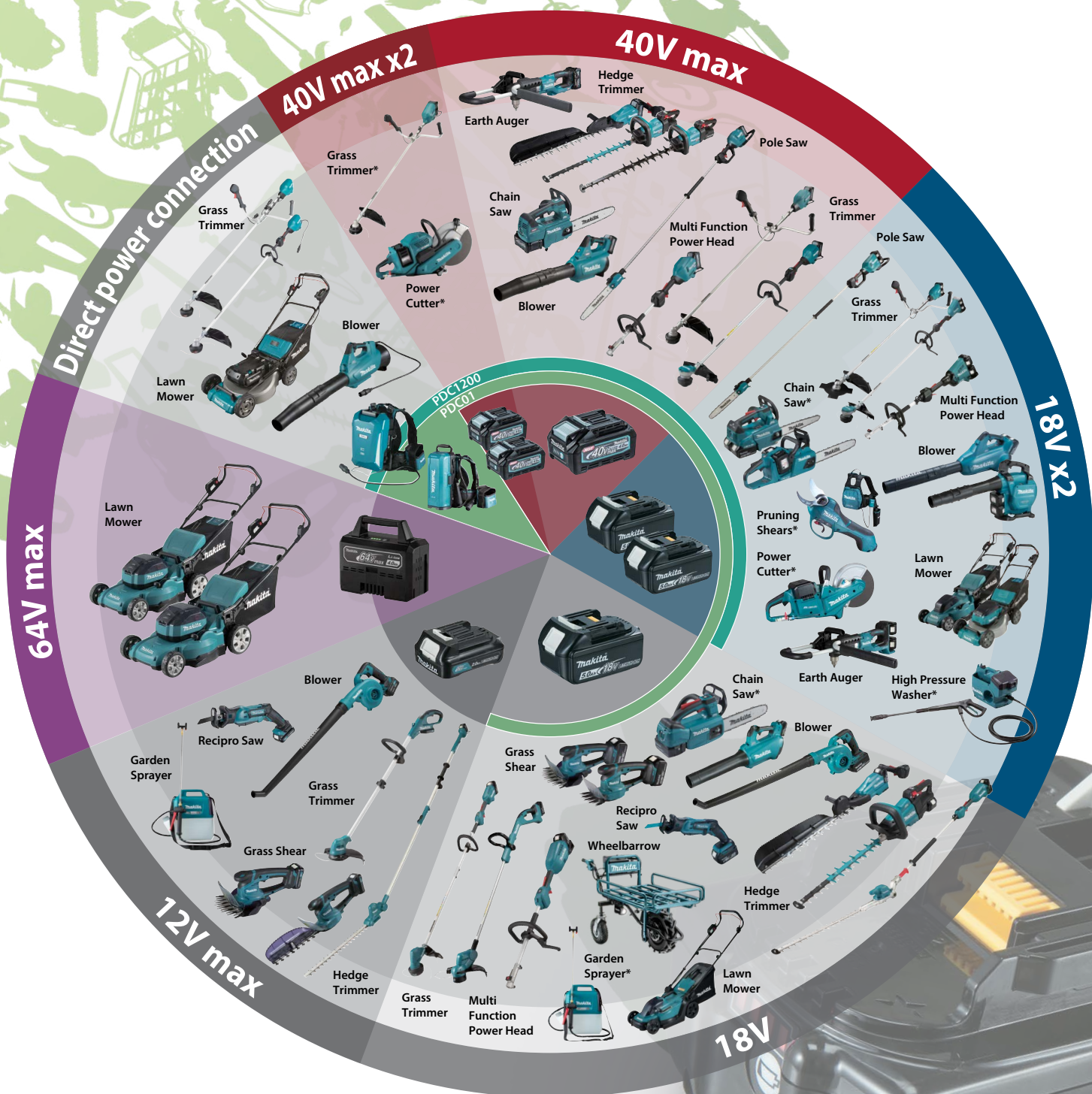

\* These models are not compatible with Portable Power Pack (PDC1200, PDC01)  
Only rear handle type chainsaws are compatible





# Portable Power Pack Compatible with Multiple Products

## PDC1200

Powered by 36V-40Vmax built-in battery

1,200 Wh high capacity

(Approx. 6 times more capacity than BL1860B x 2)

## IPX4

Charger: DC4001  
Charging time: 6 hours  
Part No. 191L01-2



**Height-adjustable waist belt**  
The position of the waist belt can be adjusted for personal fit and comfort.

**Quickly removable harness**  
can be attached/removed from the main unit with a single action.

**Reflectors**  
keep operator visible from a distance even in the dark.

### Battery Powered Models



### Adapter set

Part No. 191N62-4



### Adapter set

Part No. 191J51-5



### Adapter set

Part No. 191J50-7



## PDC01

Powered by up to four 18V LXT batteries

432 Wh high capacity

(with 4 pcs. of BL1860B)

(Batteries sold separately)

## IPX4



### PDC1200A01 / A02 Portable Power Pack

1,200 Wh high capacity



Capacity	33.5 Ah
Energy Capacity	1,206 Wh
Number of Cells	100
Charging Time (hours)	6
Power Supply Cord	Battery Side: 1.1 m (3.6 ft) Adapter Side: 0.6 m (2.0 ft) w/o Harness: 369 x 261 x 139 mm (14-1/2 x 10-1/4 x 5-1/2") w/ Harness: 428 x 261 x 164 mm (16-7/8 x 10-1/4 x 6-1/2")
Dimensions (L x W x H)	
Net weight	8.8 kg (19.4 lbs.)

40Vmax 18V x2 XGT LXT IPX4 WG

Harness, Adapter for 36V (18V x2) [countries-specific], Charger. \* PDC1200A01 (1x 18V+18V Adaptor)

### PDC01 (191A62-6 / 191A67-6) Portable Power Pack

Powered by up to four 18V LXT batteries

Li-ion Ah 6.0 | 5.0 | 3.0 | 1.5



Capacity	24 / 12 Ah
Energy Capacity	432 Wh
Dimensions (L x W x H)	400x195x132mm (15-3/4" x 7-5/8" x 5-3/16")
Net weight	1.7 kg (5.6 lbs.)

18V x2 18V XGT LXT IPX4

Harness, Adapter. \* 191A62-6 (18V+18V and 18V Adaptor), 191A67-6 (18V + 18V Adaptor only)

PRODUCTS



# DRILL

(Steel & Wood)

## DF001GM201(RM2J) / GD201(RD2J) / GZ 13mm (1/2") Cordless Driver Drill

Excellent in Continuous Heavy-Duty Work

Li-ion Ah 8.0 | 5.0 | 4.0 | 2.5 | 2.0



<b>Capacity</b>	Steel: 20 mm (13/16") Wood (Auger-Bit): 50 mm (2") Wood (Self-Feed Bit): 76 mm (3") Wood (Hole Saw): 152 mm (6")
<b>Chuck Capacity</b>	1.5 - 13 mm (1/16 - 1/2")
<b>No Load Speed (RPM)</b>	High / Low: 0 - 2,600 / 0 - 650
<b>Max Fastening Torque</b>	Hard / Soft: 140 / 68 N·m
<b>Max lock torque</b>	125 N·m (1,100 in.lbs.)
<b>Dimensions (L x W x H)</b>	w/BL4025: 181x86x275 mm w/BL4040: 181x86x282 mm
<b>Net weight</b>	2.7 - 3.0 kg (5.9 - 6.6 lbs.)

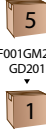

40Vmax



XGT BL AFT XPT

Side Handle, Belt Clip, (+/-) Bit, Bit Holder, Charger, Battery, Z: Battery and Charger are sold separately

## DF002GD201(RD2J) / GA201(SA2J) / GZ 13mm (1/2") Cordless Driver Drill

Compact and ergonomic design at only 170 mm (6-11/16") long

Li-ion Ah 8.0 | 5.0 | 4.0 | 2.5 | 2.0



<b>Capacity</b>	Steel/Wood: 13/38 mm (1/2"/1-1/2")
<b>Chuck Capacity</b>	1.5 - 13 mm (1/16 - 1/2")
<b>No Load Speed (RPM)</b>	High / Low: 0 - 2,200 / 0 - 600
<b>Max Fastening Torque</b>	Hard / Soft: 64/30 N·m (570 / 270 in.lbs.)
<b>Max lock torque</b>	65 N·m (580 in.lbs.)
<b>Dimensions (L x W x H)</b>	w/BL4025: 170x86x265 mm w/BL4040: 170x86x290 mm
<b>Net weight</b>	1.9 - 2.8 kg (4.2 - 6.2 lbs.)



40Vmax



XGT BL AFT XPT

(+/-) Bit, Belt Clip, Battery, Charger, Z: Battery and Charger are sold separately

## DDF486RTE / RFE / Z 13mm (1/2") Cordless Driver Drill

18V LXT BL Brushless Cordless 13 mm (1/2") 125 N·m (1,100 in.lbs.)

Li-ion Ah 6.0 | 5.0 | 3.0 | 1.5



<b>Capacity</b>	Steel: 13 mm (1/2"), Wood (Auger-Bit): 50 mm (2") Wood (Self-Feed Bit): 76 mm (3") Wood (Hole Saw): 152 mm (6"), Sliding Board: 170 mm (6-11/16")
<b>Chuck capacity</b>	1.5 - 13 mm (1/16 - 1/2")
<b>No Load Speed (RPM)</b>	High / Low: 0 - 2,100 / 0 - 550
<b>Max Fastening Torque</b>	Hard / Soft: 130 / 65 N·m
<b>Max lock torque</b>	125 N·m (1,100 in.lbs.)
<b>Dimensions (L x W x H)</b>	w/BL1830B/BL1850B/BL1860B: 178 x 81 x 265 mm
<b>Net weight</b>	2.3 - 2.6 kg (5.1 - 5.7 lbs.)



18V



LXT BL XPT

Depth Gauge, Side Handle, Belt Clip, (+/-) Bit, Bit Holder, Charger, Battery, Z: Battery and Charger are sold separately

## DDF458RTE / RFE / Z 13mm (1/2") Cordless Driver Drill

Cordless 13 mm (1/2") 84 N·m (750 in.lbs.) Driver Drill

440 Wh

Li-ion Ah 6.0 | 5.0 | 3.0 | 1.5



<b>Capacity</b>	Steel: 13 mm (1/2") Wood: 76 mm (3")
<b>No Load Speed (RPM)</b>	High: 0 - 2,000 Low: 0 - 400
<b>Max Fastening Torque</b>	Hard / Soft: 91 / 58 N·m
<b>Max lock torque</b>	84 N·m (750 in.lbs.)
<b>Dimensions (L x W x H)</b>	225x79x259 mm (8-7/8"x3-1/8"x10-1/4")
<b>Net weight</b>	2.1 - 2.5 kg (4.7 - 5.4 lbs.)



18V



LXT XPT

Charger, Battery, (+/-) Bit, Side Grip, Z: Battery and Charger are sold separately

## DDF484RTE / RTX6 / RFE / Z 13mm (1/2") Cordless Driver Drill

Cordless 13 mm (1/2") 60 N·m (530 in.lbs.) Driver Drill

Li-ion Ah 6.0 | 5.0 | 3.0 | 1.5



<b>Capacity</b>	Steel / Wood: 13 / 38 mm (1/2" / 1-1/2")
<b>Chuck capacity</b>	1.5 - 13 mm (1/16 - 1/2")
<b>No Load Speed (RPM)</b>	High / Low: 0 - 2,000 / 0 - 500
<b>Max Fastening Torque</b>	Hard / Soft: 54 / 30 N·m (480 / 270 in.lbs.)
<b>Max lock torque</b>	60 N·m (530 in.lbs.)
<b>Sound Power Level</b>	N/A dB(A)
<b>Dimensions (L x W x H)</b>	172x79x261 mm (6-3/4"x3-1/8"x10-1/4")
<b>Net weight</b>	1.5 kg (3.4 lbs.)



18V



LXT BL XPT

(+/-) bit 2-45, Belt clip, Battery, Fast Charger, Z: Battery and Charger are sold separately

## DDF482RTE / RFE / RFX1 / Z 13mm (1/2") Cordless Driver Drill

Developed as the successor to the current model DDF456

440 Wh

Li-ion Ah 6.0 | 5.0 | 3.0 | 1.5



<b>Capacity</b>	Steel / Wood: 13 / 38 mm (1/2" / 1-1/2")
<b>Chuck capacity</b>	1.5 - 13 mm (1/16 - 1/2")
<b>No Load Speed (RPM)</b>	High / Low: 0 - 1,900 / 0 - 600
<b>Max Fastening Torque</b>	Hard / Soft: 62 / 36 N·m (550 / 320 in.lbs.)
<b>Max lock torque</b>	54 N·m (480 in.lbs.)
<b>Dimensions (L x W x H)</b>	185x79x249 mm (7-1/4"x3-1/8"x9-3/4")
<b>Net weight</b>	1.5 kg (3.3 lbs.)

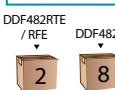

18V

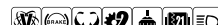

LXT XPT

Fast Charger, Battery Cartridge, (+) (-) Bit, Z: Battery and Charger are sold separately



**DDF487RFJ / Z 13mm (1/2") Cordless Driver Drill**

18V LXT BL Brushless Cordless 13 mm (1/2") 40 N-m (350 in.lbs.)

Li-ion Ah 6.0 5.0 3.0 1.5



DDF487RFJ  
1

Capacity	Steel / Wood (Auger Bit) / Wood (Self-Feed Bit) / Wood (Hole Saw): 13 / 36 / 35 / 51 mm (1/2" / 1-7/16" / 1-3/8" / 2")
Chuck Capacity	1.5 - 13 mm (1/16" - 1/2")
No Load Speed (RPM)	High / Low: 0 - 1,700 / 0 - 500
Max Fastening Torque	Hard / Soft: 40 / 25 N-m
Max Lock Torque	40 N-m (350 in.lbs.)
Dimensions (L x W x H)	w/ BL1830B / BL1850B / BL1860B: 150 x 81 x 248 mm (5-7/8" x 3-1/16" x 9-3/4")
Net weight	1.3 - 1.6 kg (2.9 - 3.5 lbs.)

18V Belt Clip, (+)(-) Bit, Battery, Charger, Z: Battery and Charger are sold separately

**DDF453RYE 13mm (1/2") Cordless Driver Drill**

Cordless 13 mm (1/2") 38 N-m (340 in.lbs.) Driver Drill

Li-ion Ah 6.0 5.0 3.0 1.5



DDF453RYE  
4

Capacity	Steel: 13 mm (1/2") Wood: 36 mm (1-7/16")
No Load Speed (RPM)	High: 0 - 1,300 Low: 0 - 400
Max Fastening Torque	Hard / Soft: 42 / 27 N-m
Max lock torque	38 N-m (340 in.lbs.)
Dimensions (L x W x H)	222x79x244 mm (8-3/4"x3-1/8"x9-5/8")
Net weight	1.7 - 2 kg (3.7 - 4.4 lbs.)

18V Fast Charger, Battery, (+)(-) Bit

**DF488D002 / D004 / DYEX4 13mm (1/2") Cordless Driver Drill**

New

18V Li-Ion Cordless 13 mm (1/2") 38 N-m (340 in.lbs.) Driver Drill, G-Battery

Li-ion Ah 2.0 1.5



Capacity	Steel: 13 mm (1/2") Wood: 36 mm (1-7/16")
No Load Speed (RPM)	High: 0 - 1,400 Low: 0 - 400
Max Fastening Torque	Hard / Soft: 42 / 24 N-m
Max lock torque	38 N-m (340 in.lbs.)
Dimensions (L x W x H)	221 x 83 x 240 mm (8-3/4" x 3-1/4" x 9-1/2")
Net weight	1.7 kg (3.7 lbs.)

18V (+)(-) Bit, Battery, Charger

**DF332DSAE / DZ 10mm (3/8") Cordless Driver Drill**

Extremely Compact and Lightweight

Li-ion Ah 4.0 2.0 1.5



DF332DSAE  
2  
DF332DZ  
4

Capacity	Steel: 10mm (3/8") Wood: 28mm (1-1/8")
Chuck Capacity	0.8 - 10 mm (3/16" - 3/8")
No Load Speed (RPM)	High: 0 - 1,500 Low: 0 - 450
Max Fastening Torque	Hard: 35 N-m Soft: 21 N-m
Max Lock Torque	32 N-m (280 in.lbs.)
Max Output	250W
Dimensions (L x W x H)	154x66x217mm (6-1/16"x2-5/8"x8-1/2")
Net Weight	1 - 1.2 kg (2.3 - 2.6 lbs)

12Vmax Battery, Charger, Battery cover, Belt clip, Phillips bit, DZ: Battery and Charger are sold separately

**DF333DSAE / DWYE / DZ 10mm (3/8") Cordless Driver Drill**

12Vmax CXT Li-Ion Cordless 28 N-m (250 in.lbs.) Driver Drill

Li-ion Ah 4.0 2.0 1.5



DF333DSAE / DWYE  
2  
DF333DZ  
4

Capacity	Steel / Wood: 10 / 21 mm (3/8" / 13/16")
Chuck capacity	0.8 - 10 mm (1/32 - 3/8")
No Load Speed (RPM)	High / Low: 0 - 1,700 / 0 - 450
Max Fastening Torque	Hard / Soft: 30 / 14 N-m (270 / 130 in.lbs.)
Max lock torque	28 N-m (250 in.lbs.)
Dimensions (L x W x H)	w/ BL1016/BL1021B: 179x66x212 mm w/ BL1041B: 179x66x229 mm
Net weight	1.1 - 1.2 kg (2.4 - 2.7 lbs.)

12Vmax Phillips Bit, Belt Clip, Battery, Charger, DZ: Battery and Charger are sold separately

**DF330DWE 10mm (3/8") Cordless Driver Drill**

Lightweight and compact but with 2-speed gear selection

Li-ion Ah 1.3



Capacity	Steel: 10 mm (3/8") Wood: 21 mm (13/16")
No Load Speed (RPM)	High: 0 - 1,300 Low: 0 - 450
Max Fastening Torque	Hard / Soft: 24 / 14 N-m
Dimensions (L x W x H)	189x53x183mm (7-7/8"x2-1/16"x7-1/4")
Net Weight	1.0kg (2.2lbs)

10.8V Battery Charger, Battery Cartridge, Phillips Bit, Holster

**DDF083RFE / Z 13mm (1/2") Cordless Driver Drill**

Ultra-compact and slim design

Li-ion Ah 6.0 5.0 3.0 1.5



DDF083RFE  
2  
DDF083Z  
6

Capacity	Steel / Wood: 13 / 36 mm (1/2" / 1-7/16")
Chuck capacity	6.35mm (1/4")
No Load Speed (RPM)	High / Low: 0 - 1,700 / 0 - 500
Max Fastening Torque	Hard / Soft: 40 / 23 N-m (350 / 210 in.lbs.)
Max lock torque	40 N-m (350 in.lbs.)
Sound Power Level	77 dB(A)
Dimensions (L x W x H)	124x79x247mm (4-7/8"x3-1/8"x9-3/4")
Net weight	1.1 kg (2.4 lbs)

18V Belt Clip, Battery, Fast Charger, Phillips bit(DDF083), Z: Battery and Charger are sold separately

**DF032DSAE / DZ 10mm (3/8") Cordless Driver Drill**

BL motor delivers 35 N-m of max torque

Li-ion Ah 4.0 2.0 1.5



DF032DSAE  
2  
DF032DZ  
4

Capacity	Steel: 10mm (3/8") Wood: 28mm (1-1/8")
Chuck Capacity	6.35mm (1/4")
No Load Speed (RPM)	High: 0 - 1,500 Low: 0 - 450
Max Fastening Torque	Hard: 35 N-m Soft: 21 N-m
Max Lock Torque	32 N-m (280 in.lbs.)
Max Output	250W
Dimensions (L x W x H)	124x66x217mm (4-7/8"x2-5/8"x8-1/2")
Net Weight	0.88 kg (1.9 - 2.3lbs)

12Vmax Battery, Charger, Battery cover, Belt clip, Phillips bit, DZ: Battery and Charger are sold separately

**DF033DSAE / DWYE / DZ**  
10mm (3/8") Cordless Driver Drill

12Vmax CXT Li-Ion Cordless 28 N-m (250 in.lbs.) Driver Drill

Li-ion Ah 4.0 2.0 1.5



Capacity	Steel / Wood: 10 / 21 mm (3/8" / 13/16")
Chuck capacity	6.35 mm (1/4")
No Load Speed (RPM)	High / Low: 0 - 1,700 / 0 - 450
Max Fastening Torque	Hard / Soft: 30 / 14 N-m (270 / 130 in.lbs.)
Max lock torque	28 N-m (250 in.lbs.)
Dimensions (L x W x H)	w/ BL1016/BL1021B: 149x66x212 mm w/ BL1041B: 149x66x229 mm
Net weight	0.92 - 1.1 kg (2.0 - 2.4 lbs.)

12Vmax



Phillips Bit, Belt Clip, Battery, Charger, DZ: Battery and Charger are sold separately

**DF030DWE** 10mm (3/8") Cordless Driver Drill

Lightweight and compact but with 2-speed gear selection

Li-ion Ah 1.3



Capacity	Steel: 10 mm (3/8") Wood: 21 mm (13/16")
No Load Speed (RPM)	High: 0-1,300 Low: 0-350
Max Fastening Torque	Hard / Soft: 24 / 14 N-m
Dimensions (L x W x H)	157x53x183mm (6-3/16"x2-1/16"x7-1/4")
Net Weight	0.89kg (2.0lbs)

10.8V



Battery Charger, Battery Cartridge, Phillips Bit, Holster

**DF012DSE** Cordless Driver Drill

7.2V Li-Ion Cordless 5 mm (3/16") Driver Drill

Li-ion Ah 1.5



Capacity	Steel: 5 mm (3/16") Wood: 6 mm (1/4")
No Load Speed (RPM)	High: 650 Low: 200
Max Fastening Torque	Hard / Soft: 5.6 / 3.6 N-m
Dimensions Straight Type (L x W)	273x44mm (10-3/4"x1-3/4")
Dimensions Pistol Type (L x W x H)	218x44x142mm (8-5/8"x1-3/4"x5-5/8")
Net Weight	0.56 kg (1.21 lbs.)

7.2V



Bit set, Battery, Charger

**DF001DW** In-Line Cordless Screwdriver

3.6V Li-Ion Cordless Screwdriver, Built-in Battery

Li-ion Ah 1.5



No Load Speed (RPM)	220
Max Fastening Torque	Hard: 4.0 N-m (35 in.lbs.) Soft: 3.0 N-m (27 in.lbs.)
Max Lock Torque	6.0 N-m (53 in.lbs.)
Charging Time (hours)	3 - 5
Dimensions (L x W x H)	Straight Style: 287 x 47 x 51 mm Pistol Style: 205 x 47 x 51 mm (8-1/8" x 1-7/8" x 2")
Net Weight	0.36 kg (0.79 lbs)

3.6V



Bit set, AC Adaptor

**DF0300** 10mm (3/8") Driver Drill

10 mm (3/8") 320 W Driver Drill with Keyless Chuck

411



Continuous rating input	320W
Capacity	Steel / Wood: 10 / 28mm (3/8" / 1-1/8")
Chuck Capacity	1.0 - 10 mm (1/32 - 3/8")
No Load Speed (RPM)	High / Low: 0 - 1,500 / 0 - 450
Max Fastening Torque	Hard / Soft: 56.0 / 21.0 N-m (500 / 190 in.lbs.)
Max lock torque	42.0 N-m (370 in.lbs.)
Sound Power Level	91 dB(A)
Dimensions (L x W x H)	220x67x206 mm (8-5/8"x2-5/8"x8-1/8")
Net weight	1.2 kg (2.7 lbs.)
Power supply cord	2.5 m (8.2 ft)



Bit

**DDA351Z** 10mm (3/8") Cordless Angle Drill

18V LXT Li-Ion Cordless 10 mm (3/8") Angle Drill, Keyless Chuck

440

Li-ion Ah 6.0 5.0 3.0 1.5



Capacity	Steel: 10 mm (3/8") Wood: 25 mm (1")
No Load Speed (RPM)	0-1,800
Dimensions (L x W x H)	326x79x115 mm (12-7/8"x3-1/8"x4-1/2")
Net Weight	1.6 - 1.9 kg (4.2 - 3.5 lbs.)

18V



Charger, Battery, Side Grip, Z: Battery and Charger are sold separately

**DA333DSAE / DZ** 10mm (3/8") Cordless Angle Drill

12Vmax CXT Li-Ion Cordless 10 mm (3/8") Angle Drill, Keyless Chuck

Li-ion Ah 4.0 2.0 1.5



Capacity	Steel: 10 mm (3/8") Wood: 12 mm (1/2")
No Load Speed (RPM)	0 - 1,100
Head Height	84 mm (3-5/16")
Center Height	23.5 mm (15/16")
Dimensions (L x W x H)	313x68x95 mm (12-3/8"x2-11/16"x3-3/4")
Net Weight	1.2 - 1.4 kg (2.7 - 3.0 lbs.)

12Vmax



Bit, Belt Clip, Battery, Charger, DZ: Battery and Charger are sold separately

**DA332DZ** 10mm (3/8") Cordless Angle Drill

12V max CXT Li-Ion Cordless 10 mm (3/8") Angle Drill, Keyed Chuck

Li-ion Ah 4.0 2.0 1.5



Capacity	Steel: 10 mm (3/8") Wood: 12 mm (1/2")
No Load Speed (RPM)	0 - 1,100
Head Height	63 mm (2-1/2")
Center Height	23.5 mm (15/16")
Dimensions (L x W x H)	313x68x86 mm (12-3/8"x2-11/16"x3-3/8")
Net Weight	1.2 - 1.3 kg (2.6 - 2.9 lbs.)

12Vmax



Chuck Key, Chuck Key Holder, Bit, Belt Clip, Battery, Charger, DZ: Battery and Charger are sold separately



**DA331DWE** 10mm (3/8") Cordless Angle Drill

The compact angle head and its small center height

Li-ion Ah 1.3

Capacity	Steel: 10 mm (3/8") Wood: 12 mm (1/2")
No Load Speed (RPM)	0-800
Dimensions (L x W x H)	310x52x88mm (12-1/4"x2-1/16"x3-1/2")
Net Weight	1.1kg (2.5lbs)



10.8V



Charger, Battery Cartridge, Battery Cover, (+)(-) Bit

**DA330DWE** 10mm (3/8") Cordless Angle Drill

The compact angle head and its small center height

Li-ion Ah 1.3

Capacity	Steel: 10 mm (3/8") Wood: 12 mm (1/2")
No Load Speed (RPM)	0-800
Dimensions (L x W x H)	298 x 52 x 77 mm (11-3/4 x 2-1/16 x 3")
Net Weight	1.1 kg (2.4 lbs.)



10.8V



Charger, Battery, Chuck Key, (+)(-) Bit

**DA3010F** 10mm (3/8") Angle Drill

Compact and light body weighs only 1.4kg (3.1lbs)

419

Continuous Rating Input	450W
Capacity	Steel: 10 mm (3/8") Wood: 25 mm (1")
No Load Speed (RPM)	0-2,400
Overall Length	270 mm (10-5/8")
Net Weight	1.6kg (3.5lbs)
Power Supply Cord	2.5m (8.2ft)



Chuck Key S10, Grip 36 Complete

**6412** 10mm (3/8") Drill

Compact and lightweight, yet with enough power

64

Continuous Rating Input	450W
Capacity	Steel: 10 mm (3/8") Wood: 25 mm (1")
No Load Speed (RPM)	0-3,400
Dimensions (L x W x H)	228x64x183mm (9"x2-1/2"x7-1/4")
Net Weight	1.3kg (2.9lbs)
Power Supply Cord	2.0m (6.6ft)



110V

6412/B



Chuck Key

**6413** 10mm (3/8") Drill

Compact and lightweight, yet with enough power

64

Continuous Rating Input	450W
Capacity	Steel: 10 mm (3/8") Wood: 25 mm (1")
No Load Speed (RPM)	0-3,400
Dimensions (L x W x H)	234x64x183mm (9-1/4"x2-1/2"x7-1/4")
Net Weight	1.3kg (2.9lbs)
Power Supply Cord	2.0m (6.6ft)



**6305** 13mm (1/2") Drill

13 mm (1/2") 850 W Drill with Keyed Chuck

303

Continuous rating input	850W
Capacity	Steel: 13 mm (1/2") Wood: 30 mm (1-3/16")
No Load Speed (RPM)	1,450
Dimensions (L x W x H)	346x84x152 mm (13-5/8"x3-5/16"x6")
Net weight	2.8 kg (6.2 lbs.)
Power supply cord	2.5 m (8.2 ft)



Chuck Key, Depth Gauge, Side Grip

**DP2010** 6.5mm (1/4") Drill

Designed For High Drilling Efficiency

419

Continuous rating input	370W
Capacity	Steel: 6.5 mm (1/4") Wood: 15 mm (9/16")
No Load Speed (RPM)	0-4,200
Dimensions (L x W x H)	209 x 64 x 175 mm (8-1/4 x 2-1/2 x 6-7/8")
Net weight	1.0 kg (2.2 lbs.)
Power supply cord	2.0 m (6.6 ft)



Depth Gauge (country-specific), Chuck Key

**DP4002/B** 13mm (1/2") Drill

Lightweight aluminum gear housing for durability

419

Continuous rating input	750W
Capacity	Steel: 13 mm (1/2") Wood: 38 mm (1-1/2")
No Load Speed (RPM)	0-700
Overall Length	304 mm (12")
Net weight	2.7 kg (5.8 lbs.)
Power supply cord	2.5 m (8.2 ft)



110V



**DP4700** 13mm (1/2") Drill

Heavy-duty performance drill for professionals

64



Continuous Rating Input	510W
Capacity	Steel: 13 mm (1/2") Wood: 36 mm (1-3/8")
No Load Speed (RPM)	0-550
Overall Length	275 mm (10-7/8")
Net Weight	2.2kg (4.8lbs)
Power Supply Cord	2.5m (8.2ft)



Chuck Key, Side Grip

**DS4011** 13mm (1/2") Drill

New aesthetic design

411



Continuous Rating Input	750W
Capacity	Steel: 13 mm (1/2") Wood: 36 mm (1-7/16")
No Load Speed (RPM)	600
Dimensions (L x W x H)	340x83x401mm (13-3/8"x3-1/4"x15-3/4")
Net Weight	2.8kg (6.3lbs)
Power Supply Cord	2.5m (8.2ft)



Chuck Key, Side Grip

PRODUCTS



**HAMMER DRILL**  
(Steel, Wood & Masonry)

**HP001GM201 (RM2J) / GD201 (RD2J) / GZ**  
13mm (1/2") Cordless Hammer Driver Drill

Delivers 35% or more higher speed than previous model

Li-ion Ah 8.0 5.0 4.0 2.5 2.0



Capacity	Steel: 20mm (13/16") Wood (Auger-Bit): 50mm (2") Wood (Self-Feed Bit): 76mm (3") Wood (Hole Saw): 152mm (6") Masonry: 20mm (13/16") 1.5-13mm (1/16-1/2")
Chuck Capacity	1.5-13mm (1/16-1/2")
Impacts Per Minute (IPM)	High/Low: 0-39,000/0-9,750
No Load Speed (RPM)	High/Low: 0-2,600/0-650
Max Fastening Torque	Hard/Soft: 140/68 N·m
Max lock torque	125 N·m (1,100 in.lbs.)
Dimensions (L x W x H)	w/ BL4025: 182x86x275 mm w/ BL4040: 182x86x282 mm
Net weight	2.7-3.0kg (6.0-6.6 lbs.)

40Vmax



Depth Gauge, Side Handle, Belt Clip, (+)(-) Bit, Bit Holder, Charger, Battery, Z: Battery and Charger are sold separately

**HP002GD201 (RD2J) / GA201 (SA2J) / GZ**  
13mm (1/2") Cordless Hammer Driver Drill

Compact and ergonomic design at only 180 mm (7-1/8") long

Li-ion Ah 8.0 5.0 4.0 2.5 2.0



Capacity	Steel/Wood/Masonry: 13/38/13mm (1/2-1/2/1/2")
Chuck Capacity	1.5-13mm (1/16-1/2")
Impacts Per Minute (IPM)	High/Low: 0-33,000/0-9,000
No Load Speed (RPM)	High/Low: 0-2,200/0-600
Max Fastening Torque	Hard/Soft: 64/30 N·m (570/270 in.lbs.)
Max lock torque	65 N·m (580 in.lbs.)
Dimensions (L x W x H)	w/ BL4025: 180x86x265 mm w/ BL4040: 180x86x290 mm
Net weight	2.0-2.9kg (4.4-6.4 lbs.)

40Vmax



Belt Clip, (+)(-) Bit, Battery, Charger, Z: Battery and Charger are sold separately



**DHP486RTE / RFE / Z**  
13mm (1/2") Cordless Hammer Driver Drill

18V LXT BL Brushless Cordless 13 mm (1/2") 125 N-m (1,100 in.lbs.)

Li-ion Ah 6.0 5.0 3.0 1.5



Capacity	Steel: 13mm (1/2"), Wood (Auger-Bit): 50mm (2"), Masonry: 16mm (5/8"), Siding Board: 170mm (6-11/16")
Chuck capacity	1.5-13mm (1/16-1/2")
Impacts Per Minute (IPM)	High/Low: 0-31,500/0-8,250
No Load Speed (RPM)	High/Low: 0-2,100/0-550
Max Fastening Torque	Hard/Soft: 130/65 N·m
Max lock torque	125 N·m (1,100 in.lbs.)
Dimensions (L x W x H)	w/ BL1830B/BL1850B/BL1860B: 178 x 81 x 265 mm
Net weight	2.3-2.7kg (5.1-6.0 lbs.)

18V



Depth Gauge, Side Handle, Belt Clip, (+)(-) Bit, Bit Holder, Charger, Battery, Z: Battery and Charger are sold separately



**DHP484RTE / RFE / Z**  
13mm (1/2") Cordless Hammer Driver Drill

Cordless 13 mm (1/2") 60 N-m (530 in.lbs.) Hammer Driver Drill

Li-ion Ah 6.0 5.0 3.0 1.5



Capacity	Steel: 13 mm (1/2") Wood: 38 mm (1-1/2") Masonry: 13 mm (1/2")
Impacts Per Minute (IPM)	High/Low: 0-30,000/0-7,500
No Load Speed (RPM)	High/Low: 0-2,000/0-500
Max Fastening Torque	Hard / Soft: 54 / 30 N-m (480 / 270 in.lbs.)
Max lock torque	60 N-m (530 in.lbs.)
Sound Power Level	99 dB(A)
Dimensions (L x W x H)	182x79x261mm
Net weight	1.6 kg (3.5 lbs)

18V **LXT BL XPT**

Fast Charger, Battery Cartridge, (+)(-) Bit, Side Grip, Depth Rod, Z: Battery and Charger are sold separately

**DHP482RTE / RFX1 / RFE / Z**  
13mm (1/2") Cordless Hammer Driver Drill

Extremely compact tool size

440

Li-ion Ah 6.0 5.0 3.0 1.5



Capacity	Steel: 13 mm (1/2") Wood: 38 mm (1-1/2") Masonry: 13 mm (1/2")
Impacts Per Minute (IPM)	High / Low: 0 - 28,500 / 0 - 9,000
No Load Speed (RPM)	High / Low: 0 - 1,900 / 0 - 600
Max Fastening Torque	Hard / Soft: 62 / 36 N-m (550 / 320 in.lbs.)
Max lock torque	54 N-m (480 in.lbs.)
Dimensions (L x W x H)	198x79x249mm (7-3/4"x3-1/8"x9-3/4")
Net weight	1.5 kg (3.4 lbs)

18V **LXT XPT**

Battery, Fast Charger, (+)(-) Bit, Z: Battery and Charger are sold separately

**DHP487RFJ / Z**  
13mm (1/2") Cordless Hammer Driver Drill

18V LXT BL Brushless Cordless 13 mm (1/2") 40 N-m (350 in.lbs.)

Li-ion Ah 6.0 5.0 3.0 1.5



Capacity	Steel / Wood (Auger Bit) / Wood (Self-Feed Bit) / Wood (Hole Saw) / Masonry: 13 / 36 / 35 / 51 / 13 mm (1/2 / 1-7/16 / 1-3/8 / 2 / 1/2")
Chuck Capacity	1.5 - 13 mm (1/16 - 1/2")
Impacts Per Minute (IPM)	High / Low: 0 - 25,500 / 0 - 7,500
No Load Speed (RPM)	High / Low: 0 - 1,700 / 0 - 500
Max Fastening Torque	Hard / Soft: 40 / 25 N-m
Max Lock Torque	40 N-m (350 in.lbs.)
Dimensions (L x W x H)	w/ BL1830B / BL1850B / BL1860B: 164 x 81 x 248 mm
Net weight	1.4 - 1.7 kg (3.1 - 3.7 lbs.)

18V **LXT BL XPT**

Belt Clip, (+)(-) Bit, Battery, Charger, Z: Battery and Charger are sold separately

**DHP453RFX4 / RYE**  
13mm (1/2") Cordless Hammer Driver Drill

Extremely compact tool size

Li-ion Ah 6.0 5.0 3.0 1.5



Capacity	Steel: 13 mm (1/2") Wood: 36 mm (1-7/16") Masonry: 13 mm (1/2")
Impacts Per Minute (IPM)	High: 0 - 19,500 Low: 0 - 6,000
No Load Speed (RPM)	High: 0 - 1,300 Low: 0 - 400
Max Fastening Torque	Hard / Soft: 42 / 27 N-m
Max lock torque	38 N-m (340 in.lbs.)
Dimensions (L x W x H)	240x79x244mm (9-7/16"x3-1/8"x9-5/8")
Net weight	1.7kg (3.7lbs)

18V **LXT** 4

Fast Charger, Battery, (+)(-) Bit, Z: Battery and Charger are sold separately

**HP488D002 / D006** 13mm (1/2") Cordless Hammer Driver Drill **New**

18V Li-Ion Cordless 13 mm (1/2") 38 N-m (340 in.lbs.) Hammer Driver Drill, G-Battery

Li-ion Ah 2.0 1.5



Capacity	Steel: 13 mm (1/2") Wood: 36 mm (1-7/16") Masonry: 13 mm (1/2")
Impacts Per Minute (IPM)	High: 0-21,000 Low: 0-6,000
No Load Speed (RPM)	High: 0-1,400 Low: 0-400
Max Fastening Torque	Hard / Soft: 42 / 24 N-m
Max lock torque	38 N-m (340 in.lbs.)
Dimensions (L x W x H)	239x83x240 mm (9-3/8"x3-1/4"x9-1/2")
Net weight	1.7 kg (3.7 lbs)

18V **G-Series**

(+)(-) Bit, Battery, Charger

**HP332DSAE / DZ** 10mm (3/8") Cordless Hammer Driver Drill

Compact and Ergonomic Design at Only 193 mm Long

Li-ion Ah 4.0 2.0 1.5



Capacity	Steel: 10mm (3/8") Wood: 28mm (1-1/8") Masonry: 8mm (5/16")
Chuck capacity	0.8 - 10 mm (1/32 - 3/8")
Impacts Per Minute (IPM)	High: 0 - 22,500 Low: 0 - 6,750
No Load Speed (RPM)	High: 0 - 1,500 Low: 0 - 450
Max Fastening Torque	Hard: 35 N-m Soft: 21 N-m
Max Lock Torque	32 N-m (280 in.lbs.)
Dimensions (L x W x H)	168x66x217mm (6-5/8"x2-5/8"x8-1/2")
Net Weight	1.1 - 1.3 kg (2.4 - 2.8 lbs)

12Vmax **CXT BL XPT**

Battery, Charger, Battery cover, Belt clip, Phillips bit, DZ: Battery and Charger are sold separately

**HP333DSAE / DWYE / DWYX3 / DZ**  
10mm (3/8") Cordless Hammer Driver Drill

12Vmax CXT Li-Ion Cordless 10 mm (3/8") 28 N-m (250 in.lbs.)

Li-ion Ah 4.0 2.0 1.5



Capacity	Steel / Wood / Masonry: 10 / 21 / 8 mm (3/8" / 13/16" / 5/16")
Impacts Per Minute (IPM)	High / Low: 0 - 25,500 / 0 - 6,750
No Load Speed (RPM)	High / Low: 0 - 1,700 / 0 - 450
Max Fastening Torque	Hard / Soft: 30 / 14 N-m
Max lock torque	28 N-m (250 in.lbs.)
Dimensions (L x W x H)	w/ BL1016/BL1021B: 193x66x212 mm w/ BL1041B: 193x66x229 mm
Net weight	1.1 - 1.3 kg (2.4 - 2.9 lbs.)

12Vmax **CXT**

Phillips Bit, Belt Clip, Battery, Charger, DZ: Battery and Charger are sold separately

**HP330DWE** 10mm (3/8") Cordless Hammer Driver Drill

Hammer drill mode

Li-ion Ah 1.3



Capacity	Steel: 10 mm (3/8") Wood: 21 mm (13/16") Masonry: 8 mm (5/16")
Impacts Per Minute (IPM)	High: 0-22,500 Low: 0-6,000
No Load Speed (RPM)	High: 0-1,500 Low: 0-400
Max Fastening Torque	Hard / Soft: 24 / 12 N-m
Dimensions (L x W x H)	201x53x183mm (7-7/8"x2-1/16"x7-1/4")
Net Weight	1.1kg (2.3lbs)

10.8V 2

Charger, Battery Cartridge, Phillips Bit, Holster, DZ: Battery and Charger are sold separately

**HP0300** 10mm (3/8") Hammer Driver Drill

10 mm (3/8") 320 W Hammer Driver Drill with Keyless Chuck

411



Continuous rating input Capacity	320W Concrete / Steel / Wood: 8 / 10 / 28mm (5/16" / 3/8" / 1-1/8")
Chuck Capacity	1.0 - 10 mm (1/32 - 3/8")
No Load Speed (RPM)	High / Low: 0 - 1,500 / 0 - 450
Blows Per Minute (BPM)	High / Low: 0 - 22,500 / 0 - 6,750
Max Fastening Torque	Hard / Soft: 56.0 / 21.0 N·m (500 / 190 in.lbs.)
Max lock torque	42.0 N·m (370 in.lbs.)
Dimensions (L x W x H)	235x67x206 mm (9-1/4"x2-5/8"x8-1/8")
Net weight	1.3 kg (2.8 lbs.)
Power supply cord	2.5 m (8.2 ft)



Bit

**HP1630** 16mm (5/8") Hammer Drill

High power 710W motor

85



110V  
**HP1630/B**

Continuous Rating Input Capacity	710W Concrete: 16 mm (5/8") Steel: 13 mm (1/2") Wood: 30 mm (1-3/16")
No Load Speed (RPM)	0 - 3,200
Impacts Per Minute (IPM)	0 - 48,000
Sound Power Level	108 dB(A)
Dimensions (L x W x H)	296x75x204mm (11-5/8"x2-15/16"x8")
Net Weight	2.1 kg (4.6 lbs)
Power Supply Cord	2.0 m (6.6 ft)



Side Grip, Chuck Key (HP1630)

**HP2050** 20mm (3/4") 2-Speed Hammer Drill

Slender and compact body with durable metal gear housing

419



Continuous Rating Input Capacity	720W Concrete: 20 mm (3/4") Steel Hi: 8mm (5/16") Steel Lo: 13mm (1/2") Wood Hi: 25mm (1") Wood Lo: 40mm (1-9/16")
Impacts Per Minute (IPM)	High: 0-58,000 Low: 0-24,000
No Load Speed (RPM)	High: 0-2,900 Low: 0-1,200
Overall Length	362 mm (14-1/4")
Net Weight	2.5kg (5.6lbs)
Power Supply Cord	2.5m (8.2ft)



Chuck Key, Side Grip, Depth Rod

**HP2070** 20mm (3/4") 2-Speed Hammer Drill

1,010W Power in slender and compact body with durable metal gear housing

419



Continuous Rating Input Capacity	1,010W Concrete: 20 mm (3/4") Steel High: 8mm (5/16") Steel Low: 16mm (5/8") Wood High: 25mm (1") Wood Low: 40mm (1-9/16")
Impacts Per Minute (IPM)	High: 0-58,000 Low: 0-24,000
No Load Speed (RPM)	High: 0-2,900 Low: 0-1,200
Overall Length	364 mm (14-3/8")
Net Weight	2.6kg (5.7lbs)
Power Supply Cord	2.5m (8.2ft)



Chuck Key, Side Grip, Depth Rod

PRODUCTS



IMPACT DRIVER

**TD001GM201 (RM2J) / GD201 (RD2J) / GZ**  
Cordless Impact Driver

High Power 220 N·m

Li-ion Ah 8.0 | 5.0 | 4.0 | 2.5 | 2.0



TD001GM201 / GD201 / GZ

Capacity- Machine screw	M4 - M8 (5/32" - 5/16")
Standard Bolt	M5 - M16 (3/16" - 5/8")
High Strength Bolt	M5 - M14 (3/16" - 9/16")
Coarse thread (in length):	22 - 125 mm (7/8" - 4-7/8")
Hex Shank	6.35 mm (1/4")
No Load Speed (RPM)	0 - 3,700 / 3,200 / 2,100 / 1,100
Impacts Per Minute (IPM)	0 - 4,400 / 3,600 / 2,600 / 1,100
Max Fastening Torque	220 N·m (1,950 in.lbs.)
Fastening Torque	Hard / Med / Soft: 170 / 50 / 20 N·m
Dimensions (L x W x H)	w/ BL4025: 120x86x245 mm w/ BL4040: 120x86x250 mm
Net weight	1.7 - 2.0 kg (3.7 - 4.4 lbs.)

40Vmax



Phillips Bit, Belt Clip, Battery, Charger, Z: Battery and Charger are sold separately



**TD003GA201 (SA2J) / GZ** Cordless Impact Driver

New

High Power 220 N·m

Li-ion Ah 8.0 | 5.0 | 4.0 | 2.5 | 2.0



Capacity- Machine screw	M4 - M8 (5/32" - 5/16")
Standard Bolt	M5 - M16 (3/16" - 5/8")
High Strength Bolt	M5 - M14 (3/16" - 9/16")
Coarse thread (in length):	22 - 125 mm (7/8" - 4-7/8")
Hex Shank	6.35 mm (1/4")
No Load Speed (RPM)	0 - 3,700 / 3,200 / 2,100 / 1,100
Impacts Per Minute (IPM)	0 - 4,100 / 3,600 / 2,600 / 1,400
Max Fastening Torque	220 N·m (1,950 in.lbs.)
Fastening Torque	Hard / Med / Soft: 170 / 50 / 20 N·m
Overall length	121mm
Net weight	1.7 - 2.9 kg (3.7 - 6.4 lbs.)

40Vmax



Belt clip, Hand strap (country-specific), Battery, Charger, Z: Battery and Charger are sold separately





# King of Impact

114 Overall length  
mm

180 Max. fastening torque  
N·m

Photo: DTD172

**Slim tool body**  
Tool head slimmer than Predecessor model enables easier screwdriving in tight corners or confined spaces.



**Anti-bit wobbling structure**  
Two ball bearings are used to securely hold the anvil for reduced bit wobbling.



### 4-stage impact power selection

Max / Hard / Medium / Soft

No load speed / Impacts per min  
Max: 0 - 3,600 / 0 - 3,800  
Hard: 0 - 3,200 / 0 - 3,600  
Medium: 0 - 2,100 / 0 - 2,600  
Soft: 0 - 1,100 / 0 - 1,100



### Light mode

- To turn on the light, set F/R change lever in the neutral position and pull the switch trigger. To turn off the light, pull the switch trigger again.
- This mode enables to use DTD172 as a handy light on dark job sites.

Left and right twin LED job lights with preglow and afterglow functions

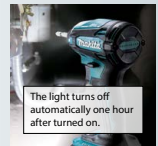

The light turns off automatically one hour after turned on.

## DTD172RFJ / RTE / Z Cordless Impact Driver

New

18V LXT BL Brushless Cordless Wood/Bolt/T-Mode 180 N-m Impact Driver

Li-ion Ah 6.0 5.0 3.0 1.5



1

Capacity - Machine screw M4 - M8 (5/32" - 5/16")  
Standard Bolt M5 - M16 (3/16" - 5/8")  
High Tensile Bolt M5 - M14 (3/16" - 9/16")  
Coarse thread (in length): 22 - 125 mm (7/8" - 4-7/8")  
Hex Shank 6.35 mm (1/4")  
No Load Speed (RPM) 0 - 3,600 / 3,200 / 2,100 / 1,100 / 1,800 / 3,600  
Impacts Per Minute (IPM) 0 - 3,800 / 3,600 / 2,600 / 1,100 / 3,800 / 3,800  
Max Fastening Torque 180 N-m (1,590 in.lbs.)  
Sound Power Level 108 dB(A)  
Dimensions (L x W x H) 116 x 79 x 236 mm (4-9/16 x 3-1/8 x 9-1/4")  
Net weight 1.2 - 1.6 kg (2.7 - 3.4 lbs.)

18V



Phillips Bit, Belt Clip, Battery, Charger, Z: Battery and Charger are sold separately

## DTD154RTE / Z Cordless Impact Driver

ULTRA-COMPACT and ergonomic design at only 117 mm long

Li-ion Ah 6.0 5.0 3.0 1.5



DTD154RTE / RFE

2

DTD154Z

6

Capacity - Machine screw M4 - M8 (5/32" - 5/16")  
Standard Bolt M5 - M16 (3/16" - 5/8")  
High Tensile Bolt M5 - M14 (3/16" - 9/16")  
Coarse thread (in length): 22 - 125 mm (7/8" - 4-7/8")  
Hex Shank 6.35 mm (1/4")  
No Load Speed (RPM) 0 - 3,600 / 0 - 2,100 / 0 - 1,100  
Impacts Per Minute (IPM) 0 - 3,800 / 0 - 2,600 / 0 - 1,100  
Max Fastening Torque 175 N-m (1,550 in.lbs.)  
Sound Power Level 107 dB(A)  
Dimensions (L x W x H) 117 x 79 x 236 mm (4-5/8" x 3-1/8" x 9-1/4")  
Net weight 1.2 kg (2.7 lbs.)

18V



Belt clip, Battery, Fast Charger, Z: Battery and Charger are sold separately

## DTD153RTE / Z Cordless Impact Driver

High Performance with Brushless DC Motor

Li-ion Ah 6.0 5.0 3.0 1.5



DTD153RTE

2

DTD153Z

3

Capacity - Machine screw M4 - M8 (5/32" - 5/16")  
Standard Bolt M5 - M16 (3/16" - 5/8")  
High Tensile Bolt M5 - M14 (3/16" - 9/16")  
Coarse thread (in length): 22 - 125 mm (7/8" - 4-7/8")  
Hex Shank 6.35 mm (1/4")  
No Load Speed (RPM) 0 - 3,400  
Impacts Per Minute (IPM) 0 - 3,600  
Max Fastening Torque 170 N-m (1,500 in.lbs.)  
Sound Power Level 107 dB(A)  
Dimensions (L x W x H) 126 x 79 x 238 mm (5" x 3-1/8" x 9-3/8")  
Net weight 1.3 kg (2.8 lbs.)

18V



Fast Charger, Battery Cartridge, Z: Battery and Charger are sold separately

## DTD152RTE / RFE / Z Cordless Impact Driver

Delivers 2,900 max RPM and 165 N-m (1,460 in.lbs.) of max torque

448

Li-ion Ah 6.0 5.0 3.0 1.5



DTD152RTE / RFE

2

DTD152Z

3

Capacity - Machine screw M4 - M8 (5/32" - 5/16")  
Standard Bolt M5 - M16 (3/16" - 5/8")  
High Tensile Bolt M5 - M12 (3/16" - 1/2")  
Coarse thread (in length): 22 - 125 mm (7/8" - 4-7/8")  
Hex Shank 6.35 mm (1/4")  
No Load Speed (RPM) 0 - 2,900  
Impacts Per Minute (IPM) 0 - 3,500  
Max Fastening Torque 165 N-m (1,460 in.lbs.)  
Sound Power Level 104 dB(A)  
Dimensions (L x W x H) 137 x 79 x 238 mm (5-3/8" x 3-1/8" x 9-3/8")  
Net weight 1.3 kg (2.8 lbs.)

18V



Belt clip, Battery, Fast Charger, Z: Battery and Charger are sold separately

## DTD156SYE / SF1J / Z Cordless Impact Driver

18V LXT Li-Ion Cordless 155 N-m (1,370 in.lbs.) Impact Driver

5

Li-ion Ah 6.0 5.0 3.0 1.5



DTD156SYE

2

Capacity - Machine screw M4 - M8 (5/32" - 5/16")  
Standard Bolt M5 - M14 (3/16" - 9/16")  
High Tensile Bolt M5 - M12 (3/16" - 1/2")  
Coarse thread (in length): 22 - 125 mm (7/8" - 4-7/8")  
Hex Shank 6.35 mm (1/4")  
No Load Speed (RPM) 0 - 2,500  
Impacts Per Minute (IPM) 0 - 3,000  
Max Fastening Torque 155 N-m (1,370 in.lbs.)  
Sound Power Level 103 dB(A)  
Dimensions (L x W x H) 43 x 79 x 241 mm (5-5/8" x 3-1/8" x 9-1/2")  
Net weight 1.3 - 1.6 kg (2.9 - 3.6 lbs.)

18V



Belt Clip, Battery, Fast Charger Bit, Z: Battery and Charger are sold separately

## DTD157RTJ / Z Cordless Impact Driver

New

Anti-bit wobbling structure

Li-ion Ah 6.0 5.0 3.0 1.5



DTD157RTJ

1

DTD157Z

4

Capacity - Machine screw M4 - M8 mm (5/32" - 5/16")  
Standard Bolt M5 - M14 (3/16" - 9/16")  
High Tensile Bolt M5 - M12 (3/16" - 1/2")  
Coarse thread (in length): 22 - 90 mm (7/8" - 3-1/2")  
Hex Shank 6.35 mm (1/4")  
No Load Speed (RPM) Hard/Soft: 0-3,000/0-1,300  
Impacts Per Minute (IPM) Hard/Soft: 0-3,900/0-1,600  
Max Fastening Torque 140 N-m (1,240 in.lbs.)  
Dimensions (L x W x H) 133 x 81 x 232 mm (5-1/4 x 3-3/16 x 9-1/8")  
Net weight 1.2 - 1.5 kg (2.7 - 3.3 lbs.)

18V



Belt Clip, Battery, Fast Charger, Z: Battery and Charger are sold separately

## TD111DSAE / DZ Cordless Impact Driver Drill

Ultra compact and slim design at only 135 mm (5-5/16") long

Li-ion Ah 4.0 2.0 1.5



TD111DSAE

2

TD111DZ

4

Capacity- Machine screw	M4 - M8 (5/32" - 5/16")
Standard Bolt	M5 - M14 (3/16" - 9/16")
High Tensile Bolt	M5 - M12 (3/16" - 1/2")
Coarse thread (in length):	22 - 90mm (7/8" - 3-1/2")
Hex Shank	6.35 mm (1/4")
No Load Speed (RPM)	High: 0 - 3,000 Low: 0 - 1,300
Impacts Per Minute (IPM)	High: 0 - 3,900 Low: 0 - 1,600
Max Fastening Torque	135 N-m (1,200 in.lbs.)
Dimensions (L x W x H)	135x66x210mm (5-5/16"x2-5/8"x8-1/4")
Net Weight	0.97 - 1.1kg (2.1 - 2.5lbs)

12Vmax



Battery, Charger, Belt Clip, Phillips Bit, DZ: Battery and Charger are sold separately

## TD110DSAE / DWYE / DZ Cordless Impact Driver Drill

12Vmax CXT Li-Ion Cordless 110 N-m (970 in.lbs.) Impact Driver

Li-ion Ah 4.0 2.0 1.5



TD110DSAE / DWYE

4

TD110DZ

3

Capacity- Machine screw	M4 - M8mm (5/32" - 5/16")
Standard Bolt	M5 - M12 (3/16" - 1/2")
High Tensile Bolt	M5 - M10 (3/16" - 3/8")
Coarse thread (in length):	22 - 90mm (7/8" - 3-1/2")
Hex Shank	6.35 mm (1/4")
No Load Speed (RPM)	0 - 2,600
Impacts Per Minute (IPM)	0 - 3,500
Max Fastening Torque	110 N-m (970 in.lbs.)
Dimensions (L x W x H)	153x66x204mm (6"x2-5/8"x8-1/8")
Net Weight	1 - 1.2kg (2.3 - 2.6 lbs)

12Vmax



Battery, Charger, Battery cover, Belt clip, Phillips bit, DZ: Battery and Charger are sold separately

## TD090DWE Cordless Impact Driver

High operation efficiency with 10.8V Li-ion battery

Li-ion Ah 1.3



Capacity- Machine screw	M4 - M8 (5/32" - 5/16")
Standard Bolt	M5 - M12 (3/16" - 1/2")
High Tensile Bolt	M5 - M10 (3/16" - 3/8")
Coarse thread (in length):	22 - 90mm (7/8" - 3-1/2")
No Load Speed (RPM)	0 - 2,400
Impacts Per Minute (IPM)	0 - 3,000
Max Fastening Torque	90 N-m (800 in.lbs.)
Dimensions (L x W x H)	155x54x178mm (6-1/8"x2-1/8"x7")
Net Weight	0.92kg (2.0lbs)

10.8V



5

Battery Charger, Battery Cartridge, Holster

## TD022DSE Cordless Impact Driver

Compact and lightweight for easy handling

Li-ion Ah 1.5



Capacity- Machine screw	M3 - M8 (1/8" - 5/16")
Standard Bolt	M3 - M8 (1/8" - 5/16")
High Tensile Bolt	M3 - M6 (1/8" - 1/4")
Coarse thread (in length):	22 - 45mm (7/8" - 1-3/4")
Hex Shank	6.35 mm (1/4")
No Load Speed (RPM)	0 - 2,450
Impacts Per Minute (IPM)	0 - 3,000
Max Fastening Torque	25 N-m (220 in.lbs.)
Dimensions Straight Type (L x W x H)	282x42x52mm (11-1/8"x1-5/8"x2-1/16")
Dimensions Pistol Type (L x W x H)	227x42x142mm (8-15/16"x1-5/8"x5-5/8")
Net Weight	0.55 - 0.56 kg (1.2 lbs)

7.2V



4

Holster, Bit set, Battery, Charger

## DTS141RTE / Z Cordless Oil-Pulse Driver

18V LXT BL Brushless Cordless Oil-Pulse Driver

Li-ion Ah 6.0 5.0 3.0 1.5



DTS141RTE

4

Capacity- Machine screw	M4 - M8 (5/32" - 5/16")
Standard Bolt	M5 - M8 (3/16" - 5/16")
High Strength Bolt	M5 - M6 (3/16" - 1/4")
Coarse thread (in length):	22 - 125 mm (7/8" - 4-7/8")
No Load Speed (RPM)	0 - 3,200/0 - 2,000/0 - 1,200
Impacts Per Minute (IPM)	0 - 2,700/0 - 2,200/0 - 1,400
Max Fastening Torque	40 N-m (355 in.lbs.)
Dimensions (L x W x H)	136 x 79 x 240 mm (5-3/8 x 3-1/8 x 9-1/2")
Net weight	1.3 - 1.6 kg (2.8 - 3.5 lbs.)

18V



3



Charger, Battery, Z: Battery and Charger are sold separately

## TD0101F Impact Driver

Compact design for perfect handling

411



Continuous Rating Input	230W
Capacity- Machine screw	M4 - M8 (5/32" - 5/16")
Standard Bolt	M5 - M14 (3/16" - 9/16")
High Tensile Bolt	M5 - M10 (3/16" - 3/8")
Coarse thread (in length):	22 - 90mm (7/8" - 3-1/2")
Driving Shank (Hex)	6.35mm (1/4")
Impacts Per Minute (IPM)	0 - 3,200
No Load Speed (RPM)	0 - 3,600
Max Fastening Torque	100 N-m (74 ft.lbs.)
Dimensions (L x W x H)	184x67x192mm (7-1/4"x2-5/8"x7-9/16")
Net Weight	0.99kg (2.2lbs)
Power Supply Cord	2.5m (8.2ft)



Phillips Bit

## DTL061Z Cordless Angle Impact Driver

Compact angle head for easy access in tight places

Li-ion Ah 6.0 5.0 3.0 1.5



Capacity- Machine screw	M4 - M8 (5/32" - 5/16")
Standard Bolt	M4 - M12 (5/32" - 1/2")
High Tensile Bolt	M4 - M8 (5/32" - 5/16")
Coarse thread (in length):	22 - 75 mm (7/8" - 2-31/32")
Hex Shank	6.35 mm (1/4")
No Load Speed (RPM)	0 - 2,000
Impacts Per Minute (IPM)	0 - 3,000
Max Fastening Torque	60 N-m (530 in.lbs.)
Dimensions (L x W x H)	387x78x116 mm (15-1/4"x3-1/16"x4-9/16")
Net weight	1.4 - 2.0 kg (3.1 - 4.3 lbs)

18V



5

Z: Battery and Charger are sold separately

## TL064DZ Cordless Angle Impact Driver

12Vmax CXT Li-Ion Cordless 60 N-m (530 in.lbs.) Angle Impact Driver

Li-ion Ah 4.0 2.0 1.5



Capacity	Machine Screw: M4 - M8 (5/32" - 5/16") Standard Bolt: M4 - M12 (5/32" - 1/2") High Tensile Bolt: M4 - M8 (5/32" - 5/16") Coarse thread (in length): 22 - 75 mm (7/8" - 2-31/32")
Hex Shank	6.35 mm (1/4")
No Load Speed (RPM)	0 - 2,000
Impacts Per Minute (IPM)	0 - 3,000
Max Fastening Torque	60 N-m (530 in.lbs.)
Dimensions (L x W x H)	361x66x86 mm (14-1/4"x2-5/8"x3-3/8")
Net Weight	1.2 - 1.6 kg (2.7 - 3.6 lbs)

12Vmax



5

Phillips Bit, Belt Clip, Battery, Charger, DZ: Battery and Charger are sold separately



PRODUCTS

# IMPACT WRENCH

## TW001GM204(RM2JX) / GD203(RD2JX) / GD201(RD2J) / GZ 19mm (3/4") Cordless Impact Wrench

Over 2,000 N-m of nut-busting torque

Li-ion Ah 8.0 | 5.0 | 4.0 | 2.5 | 2.0



<b>Fastening Capacities</b>	Standard Bolt: M12 - M36 (1/2" - 1-7/16") High Strength Bolt: M10 - M27 (3/8" - 1-1/16") 19 mm (3/4")
<b>Square Drive</b>	19 mm (3/4")
<b>No Load Speed (RPM)</b>	Max / Hard / Med / Soft: 0 - 1,800 / 0 - 1,400 / 0 - 1,150 / 0 - 950
<b>Impacts Per Minute (IPM)</b>	Max / Hard / Med / Soft: 0 - 2,500 / 0 - 2,400 / 0 - 2,200 / 0 - 1,900
<b>Max Fastening Torque</b>	1,800 N-m (1,330 ft.lbs.)
<b>Dimensions (L x W x H)</b>	w/ BL4025: 217 x 94 x 297 mm w/ BL4040: 217 x 94 x 303 mm
<b>Net weight</b>	3.9 - 4.2 kg (8.6 - 9.3 lbs.)

40Vmax



Belt Clip, Battery, Charger, Z: Battery and Charger are sold separately

## TW007GM201(RM2J) / GD201(RD2J) / GZ 12.7mm (1/2") Cordless Impact Wrench

Increased torque 730 N-m (540 ft.lbs.)

Li-ion Ah 8.0 | 5.0 | 4.0 | 2.5 | 2.0



<b>Fastening Capacities</b>	Standard Bolt: M10 - M24 (3/8" - 1") High Strength Bolt (Grade 10.9): M10 - M16 (3/8" - 5/8") High Strength Bolt (Grade F10T): M12, M16 (7/16, 5/8")
<b>Square Drive</b>	12.7 mm (1/2")
<b>No Load Speed (RPM)</b>	Max / Hard / Mid / Soft: 0 - 2,300 / 1,900 / 1,200 / 600
<b>Impacts Per Minute (IPM)</b>	Max / Hard / Mid / Soft: 0 - 2,900 / 2,700 / 1,900 / 1,200
<b>Max Fastening Torque</b>	730 N-m (540 ft.lbs.)
<b>Dimensions (L x W x H)</b>	w/ BL4025: 170 x 86 x 285 mm
<b>Net weight</b>	2.7 - 3.3 kg (6.0 - 7.3 lbs.)

40Vmax



Belt Clip, Battery, Charger, Z: Battery and Charger are sold separately

## TW004GM202(RM2J) / GD201(RD2J) / GZ 12.7mm (1/2") Cordless Impact Wrench

Increased motor speed under load delivers higher torque

Li-ion Ah 8.0 | 5.0 | 4.0 | 2.5 | 2.0



<b>Fastening Capacities</b>	Standard Bolt: M10 - M20 (3/8" - 3/4") High Strength Bolt: M10 - M16 (3/8" - 5/8") 12.7 mm (1/2")
<b>Square Drive</b>	12.7 mm (1/2")
<b>No Load Speed (RPM)</b>	Max / Hard / Med / Soft: 0 - 3,200 / 2,600 / 1,800 / 1,000
<b>Impacts Per Minute (IPM)</b>	Max / Hard / Med / Soft: 0 - 4,000 / 3,400 / 2,600 / 1,800
<b>Max Fastening Torque</b>	350 N-m (260 ft.lbs.)
<b>Dimensions (L x W x H)</b>	w/ BL4025: 144 x 86 x 248 mm w/ BL4040: 144 x 86 x 253 mm
<b>Net weight</b>	1.9 - 2.2 kg (4.2 - 4.9 lbs.)

40Vmax



Belt Clip, Battery, Charger, Z: Battery and Charger are sold separately

## DTW1001JX2 / Z 19mm (3/4") Cordless Impact Wrench

Electronic 3 stage impact power selection reduces fault tightening

Li-ion Ah 6.0 | 5.0 | 3.0 | 1.5



<b>Fastening Capacities</b>	Standard Bolt: M12 - M30 (1/2" - 1-1/4") High Tensile Bolt: M10 - M24 (3/8" - 1")
<b>Square Drive</b>	19 mm (3/4")
<b>No Load Speed (RPM)</b>	Hard / Medium / Soft: 0 - 1,800 / 0 - 1,000 / 0 - 900
<b>Impacts Per Minute (IPM)</b>	Hard / Medium / Soft: 0 - 2,200 / 0 - 2,000 / 0 - 1,800
<b>Max Fastening Torque</b>	1,050 N-m (780 ft.lbs.)
<b>Sound Power Level</b>	109 dB(A)
<b>Dimensions (L x W x H)</b>	229 x 91 x 289 mm (9" x 3-5/8" x 11-3/8")
<b>Net weight</b>	3.4 kg (7.6 lbs.)

18V



Fast charger, Battery cartridge (Tool does not come with socket), Z: Battery and Charger are sold separately

### Increased max fastening torque



Max fastening torque  
**350**  
N-m

Nut-busting torque  
**630**  
N-m

### Compact and High Torque

Compact design with a short overall length of 144mm



Photo: TW004G



High-strength anvil

Double spring

Excellent performance in continuous heavy operation due to Optimum power supply system

Able to use 2 batteries consecutively



Number of bolts consecutively tightened under heavy load\*\*  
approx  
**560**  
bolts

## DTW1002JX2 / Z 12.7mm (1/2") Cordless Impact Wrench

Cordless 3-Speed 1/2" (12.7mm) 1,000 N-m (740 ft.lbs.) Impact Wrench

Li-ion Ah 6.0 5.0 3.0 1.5



DTW1002RTJ



DTW1002Z



Fastening Capacities	Standard Bolt:	M12 - M30 (1/2" - 1-1/4")
	High Tensile Bolt:	M10 - M24 (3/8" - 1")
Square Drive		12.7 mm (1/2")
No Load Speed (RPM)	Hard / Medium / Soft:	0 - 1,800 / 0 - 1,000 / 0 - 900
Impacts Per Minute (IPM)	Hard / Medium / Soft:	0 - 2,200 / 0 - 2,000 / 0 - 1,800
		1,000 N-m (740 ft.lbs.)
Max Fastening Torque		108 dB(A)
Sound Power Level		229x91x289mm
Dimensions (L x W x H)		(9"x3-5/8"x11-3/8")
Net weight		3.3kg (7.3lbs)

18V



Fast charger, Battery cartridge (Tool does not come with socket), Z: Battery and Charger are sold separately

## DTW800RMJ 11.1mm (7/16") Cordless Impact Wrench

Cordless 3-Speed 7/16" (11.2mm) 800 N-m (590 ft.lbs.) Impact Wrench

Li-ion Ah 6.0 5.0 3.0 1.5



Fastening Capacities	Standard Bolt:	M12 - M24 (1/2" - 1")
	High Tensile Bolt:	M10 - M22 (3/8" - 7/8")
Hex Shank		11.1 mm (7/16")
No Load Speed (RPM)	Hard / Medium / Soft:	0 - 1,800 / 0 - 1,000 / 0 - 900
Impacts Per Minute (IPM)	Hard / Medium / Soft:	0 - 2,200 / 0 - 2,000 / 0 - 1,800
		800 N-m (590 ft.lbs.)
Max Fastening Torque		106 dB(A)
Sound Power Level		229x91x303mm
Dimensions (L x W x H)		(9"x3-5/8"x11-7/8")
Net weight		3.4kg (7.6lbs)

18V



Fast charger, Battery cartridge (Tool does not come with socket), Z: Battery and Charger are sold separately

## DTW700RTJ / RFJ / Z 12.7mm (1/2") Cordless Impact Wrench

BL motor delivers 700 N-m (520 ft.lbs.) of max torque

Li-ion Ah 6.0 5.0 3.0 1.5



DTW700RTJ



DTW700Z



Fastening Capacities	Standard Bolt:	M10 - M24 (3/8" - 1")
	High Strength Bolt:	M10 - M16 (3/8" - 5/8")
Square Drive		12.7 mm (1/2")
No Load Speed (RPM)	Max / Hard / Mid / Soft:	0 - 2,200 / 1,900 / 1,200 / 500
Impacts Per Minute (IPM)	Max / Hard / Mid / Soft:	0 - 2,700 / 2,400 / 1,700 / 1,000
		700 N-m (520 ft.lbs.)
Max Fastening Torque		w/ BL1830B / BL1850B / BL1860B:
Dimensions (L x W x H)		170x81x276 mm (6-11/16"x3-3/16"x10-7/8")
Net weight		2.3 - 2.7 kg (5.1 - 6.0 lbs.)

18V



Belt Clip, Battery, Charger, Z: Battery and Charger are sold separately



## DTW450RTE / Z 12.7mm (1/2") Cordless Impact Wrench

Maximum fastening torque of 440 N-m (3,900 in.lbs.)

441

Li-ion Ah 6.0 5.0 3.0 1.5



DTW450Z



DTW450RTE



Fastening Capacities	Standard Bolt:	M12 - M22 (1/2" - 7/8")
	High Tensile Bolt:	M12 - M16 (1/2" - 5/8")
Square Drive		12.7 mm (1/2")
No Load Speed (RPM)		1,600
Impacts Per Minute (IPM)		2,200
Max Fastening Torque		440 N-m (325 ft.lbs.)
Sound Power Level		105 dB(A)
Dimensions		266x82x290mm
Dimensions (L x W x H)		(10-1/2"x3-1/4"x11-3/8")
Net weight		3.4kg (7.5lbs)

18V



Fast Charger, Battery Cartridge, Z: Battery and Charger are sold separately (Tool does not come with socket)

## DTW300RTJ / RFJ / Z 12.7mm (1/2") Cordless Impact Wrench

BL motor delivers 330 N-m (240 ft.lbs.) of max torque

Li-ion Ah 6.0 5.0 3.0 1.5



DTW300RTJ



Fastening Capacities	Standard Bolt:	M10 - M20 (3/8" - 3/4")
	High Strength Bolt:	M10 - M16 (3/8" - 5/8")
Square Drive		12.7 mm (1/2")
No Load Speed (RPM)	Max / Hard / Mid / Soft:	0 - 3,200 / 0 - 2,600 / 0 - 1,800 / 0 - 1,000
Impacts Per Minute (IPM)	Max / Hard / Mid / Soft:	0 - 4,000 / 0 - 3,400 / 0 - 2,600 / 0 - 1,800
		330 N-m (240 ft.lbs.)
Max Fastening Torque		w/ BL1830B / BL1850B / BL1860B:
Dimensions (L x W x H)		144x81x246 mm (5-5/8"x3-3/16"x9-11/16")
Net weight		1.5 - 1.8 kg (3.4 - 4.1 lbs.)

18V



Belt Clip, Battery, Charger, Z: Battery and Charger are sold separately

## DTW251RTE / Z 12.7mm (1/2") Cordless Impact Wrench

High torque to weight ratio at 230 N-m (2,040 in.lbs.)

448

Li-ion Ah 6.0 5.0 3.0 1.5



Fastening Capacities	Standard Bolt:	M10 - M16 (3/8" - 5/8")
	High Tensile Bolt:	M10 - M14 (3/8" - 9/16")
Square Drive		12.7 mm (1/2")
No Load Speed (RPM)		0 - 2,100
Impacts Per Minute (IPM)		0 - 3,200
Max Fastening Torque		230 N-m (170 ft.lbs.)
Sound Power Level		105 dB(A)
Dimensions		165x79x234mm
Dimensions (L x W x H)		(6-1/2"x3-1/8"x9-1/4")
Net weight		1.5kg (3.3lbs)

18V



Fast Charger, Battery Cartridge, Z: Battery and Charger are sold separately (Tool does not come with socket)

## DTW181ZK 12.7mm (1/2") Cordless Impact Wrench

BL motor delivers 210 N-m (155 ft.lbs.) of max torque

Li-ion Ah 6.0 5.0 3.0 1.5



Fastening Capacities	Standard Bolt:	M8 - M16 (5/16" - 5/8")
	High Tensile Bolt:	M6 - M12 (1/4" - 1/2")
Square Drive		12.7 mm (1/2")
No Load Speed (RPM)	Hard / Soft:	0 - 2,400 / 0 - 1,300
Impacts Per Minute (IPM)	Hard / Soft:	0 - 3,600 / 0 - 2,000
		210 N-m (155 ft.lbs.)
Max Fastening Torque		151 x 79 x 235 mm
Dimensions		(5-15/16"x3-1/8"x9-1/4")
Dimensions (L x W x H)		
Net weight		1.2 - 1.5 kg (2.7 - 3.4 lbs)

18V



Belt Clip, Battery, Fast Charger, Z: Battery and Charger are sold separately



**DTW190RFE / Z**  
12.7mm (1/2") Cordless Impact Wrench

190 N-m (140 ft.lbs.) of Max torque optimal for scaffold bulding

Li-ion Ah 6.0 5.0 3.0 1.5



Fastening Capacities	Standard Bolt:	M8 - M16 (5/16" - 5/8")
	High Tensile Bolt:	M8 - M12 (5/16" - 1/2")
Square Drive		12.7 mm (1/2")
No Load Speed (RPM)		0 - 2,300
Impacts Per Minute (IPM)		0 - 3,000
Max Fastening Torque		190 N-m (140 ft.lbs.)
Sound Power Level		105 dB(A)
Overall Length		176 mm (6-15/16")
Net weight		1.4 kg (3.2 lbs)

18V LXT

Fast Charger, Battery Cartridge, Z: Battery and Charger are sold separately

**DTW180RFE / Z** 9.5mm (3/8") Cordless Impact Wrench

Lightweight & Compact 55 mm Width of Motor Portion

Li-ion Ah 6.0 5.0 3.0 1.5



DTW180RFE   
DTW180Z

Fastening Capacities	Standard Bolt:	M8 - M16 (5/16" - 5/8")
	High Tensile Bolt:	M6 - M12 (1/4" - 1/2")
Square Drive		9.5 mm (3/8")
No Load Speed (RPM)		Hard / Soft 0-2,400 / 0-1,300
Impacts Per Minute (IPM)		Hard / Soft 0-3,600 / 0-2,000
Max Fastening Torque		180 N-m (130 ft.lbs.)
Dimensions (L x W x H)		144 x 79 x 235 mm (5-5/8" x 3-1/8" x 9-1/4")
Net weight		1.2 kg (2.7 lbs)

18V LXT BL XPT

Belt Clip, Battery, Fast Charger, Z: Battery and Charger are sold separately

**TW160DSAE / DSME / DZ**  
9.5mm (3/8") Cordless Impact wrench

12Vmax CXT BL Brushless Impact Wrench

Li-ion Ah 4.0 2.0 1.5



TW160DSAE / DSME   
TW160DZ

Fastening Capacities	Standard Bolt:	M8 - M16 (5/16" - 5/8")
	High Tensile Bolt:	M6 - M12 (1/4" - 1/2")
Square Drive		9.5 mm (3/8")
No Load Speed (RPM)		0 - 2,400 / 0 - 1,300
Impacts Per Minute (IPM)		High / Low: 0 - 3,600 / 0 - 2,000
Max Fastening Torque		160 N-m (1,420 in.lbs.)
Dimensions (L x W x H)		w/ BL1041B: 144x66x232 mm (5-5/8"x2-5/8"x9-1/8")
Net weight		1.0 - 1.2 kg (2.2 - 2.6 lbs.)

12Vmax CXT BL

Belt Clip, Battery, Charger, DZ: Battery and Charger are sold separately

**TW141DSAE / DZ**  
12.7mm (1/2") Cordless Impact wrench

12Vmax CXT Li-Ion Cordless 1/2" (12.7 mm) 145 N-m (107 ft.lbs.) Impact Wrench

Li-ion Ah 4.0 2.0 1.5



Fastening Capacities	Standard Bolt:	M8 - M16 (5/16" - 5/8")
	High Tensile Bolt:	M6 - M12 (1/4" - 1/2")
Square Drive		12.7 mm (1/2")
No Load Speed (RPM)		0 - 2,600
Impacts Per Minute (IPM)		0 - 3,200
Max Fastening Torque		145 N-m (107 ft.lbs.)
Dimensions (L x W x H)		w/ BL1016/BL1021B: 168x66x205 mm (6-5/8"x2-5/8"x8-1/8") w/ BL1041B: 168x66x224 mm (6-5/8"x2-5/8"x8-7/8")
Net weight		1.1 - 1.2 kg (2.4 - 2.7 lbs.)

12Vmax CXT

Belt Clip, Battery, Charger, DZ: Battery and Charger are sold separately

**TW140DSAEX**  
9.5mm (3/8") Cordless Impact wrench

12Vmax CXT Li-Ion Cordless Impact Wrench

Li-ion Ah 4.0 2.0 1.5



Fastening Capacities	Standard Bolt:	M8 - M16 (5/16" - 5/8")
	High Tensile Bolt:	M6 - M12 (1/4" - 1/2")
Square Drive		9.5 mm (3/8")
No Load Speed (RPM)		0 - 2,600
Impacts Per Minute (IPM)		0 - 3,200
Max Fastening Torque		140 N-m (1,240 in.lbs.)
Dimensions (L x W x H)		w/ BL1016/BL1021B: 161x66x205 mm (6-3/8"x2-5/8"x8-1/8") w/ BL1041B: 161x66x224 mm (6-3/8"x2-5/8"x8-7/8")
Net weight		1 - 1.2 kg (2.3 - 2.7 lbs.)

12Vmax CXT

Belt Clip, Battery, Charger

**TW060DSAE / DZ** 6.35mm (1/4") Cordless Impact Wrench

Delivers 60 N-m (530 in.lbs.) of Max Torque in an Ultra Compact Size

Li-ion Ah 4.0 2.0 1.5



Fastening Capacities	Standard Bolt:	M8 - M12 (5/16" - 15/32")
	High Tensile Bolt:	M6 - M10 (1/4" - 3/8")
Square Drive		6.35 mm (1/4")
No Load Speed (RPM)		0 - 2,600
Impacts Per Minute (IPM)		0 - 3,200
Max Fastening Torque		60 N-m (530 in.lbs.)
Dimensions (L x W x H)		w/ BL1016/BL1021B: 161x66x205 mm (6-3/8"x2-5/8"x8-1/8") w/ BL1041B: 161x66x224 mm (6-3/8"x2-5/8"x8-7/8")
Net weight		1 - 1.2 kg (2.3 - 2.6 lbs.)

12Vmax CXT

Belt Clip, Battery, Charger, DZ: Battery and Charger are sold separately

**TW0200** 12.7mm (1/2") Impact Wrench

Aluminum hammer case with high durability (200N.m [150ft.lbs])

411



Continuous Rating Input	380W	
Fastening Capacities	Standard Bolt:	M10 - M16 (3/8" - 5/8")
	High Tensile Bolt:	M10 - M12 (3/8" - 1/2")
	Square Drive	12.7 mm (1/2")
No Load Speed (RPM)		0 - 2,200
Impacts Per Minute (IPM)		0 - 2,200
Max Fastening Torque		200 N-m (150 ft.lbs.)
Sound Power Level		104 dB(A)
Dimensions (L x W x H)		251 x 72 x 220mm (9-7/8" x 2-13/16" x 8-5/8")
Net Weight		2.1 kg (4.7 lbs)
Power Supply Cord		2.5m (8.2ft)

Socket (24mm)

**TW0350** 12.7mm (1/2") Impact Wrench

Incredibly high torque of 350N.m (260ft.lbs)

411



Continuous Rating Input	400W	
Fastening Capacities	Standard Bolt:	M12 - M22 (1/2" - 7/8")
	High Tensile Bolt:	M12 - M16 (1/2" - 5/8")
	Square Drive	12.7 mm (1/2")
No Load Speed (RPM)		2,000
Impacts Per Minute (IPM)		2,000
Max Fastening Torque		350 N-m (260 ft.lbs.)
Sound Power Level		104 dB(A)
Dimensions (L x W x H)		283x87x233mm (11-1/8" x 3-7/16" x 9-1/8")
Net Weight		3.0kg (6.6lbs)
Power Supply Cord		2.5m (8.2ft)

110V

Socket

## 6906 19mm (3/4") Impact Wrench

Powerful torque of 588N.m(441ft.lbs) for super-duty applications

100



Continuous Rating Input Capacity	850W
Standard Bolt:	M16 - M22 (5/8" - 7/8")
High Tensile Bolt:	M16 - M20 (5/8" - 3/4")
Square Drive	19 mm (3/4")
No Load Speed (RPM)	1,700
Impacts Per Minute (IPM)	1,600
Max Fastening Torque	588 N-m (441 ft.lbs.)
Sound Power Level	109 dB(A)
Overall Length	327 mm (12-7/8")
Net Weight	5.6kg (12.3lbs)
Power Supply Cord	2.5m (8.2ft)



Side Grip, Socket

## TW1000 25.4mm (1") Impact Wrench

Huge 1,000 N-m (738 ft.lbs.) of Power for Industrial Applications

153



110V

TW1000/B



Socket 41-80, Side Grip

Continuous Rating Input	1,200W
Fastening Capacities	Standard Bolt: M24-M30 (15/16" - 1-3/16") High Tensile Bolt: M22 - M24 (7/8" - 15/16")
Square Drive	25.4 mm (1")
No Load Speed (RPM)	1,400
Impacts Per Minute (IPM)	1,500
Max Fastening Torque	1,000 N-m (738 ft.lbs.)
Sound Power Level	114 dB(A)
Dimensions (L x W x H)	382x110x290mm (15"x4-5/16"x11-3/8")
Net Weight	8.8kg (19.4lbs)
Power Supply Cord	2.5m (8.2ft)

## DWR180RF / Z

9.5mm / 6.35mm (3/8 / 1/4") Cordless Ratchet Wrench

18V LXT Li-Ion Cordless 47.5 N-m (420 in.lbs.) Ratchet Wrench

Li-ion Ah 6.0 5.0 3.0 1.5



Capacity	Standard Bolt: M5 - M12 (3/16 - 1/2") High Strength Bolt: M5 - M10 (3/16 - 3/8")
Square Drive	9.5 / 6.35 mm (3/8 / 1/4")
No Load Speed (RPM)	0 - 800
Max Fastening Torque	47.5 N-m (420 in.lbs.)
Dimensions (L x W x H)	w/ BL1830B / BL1850B / BL1860B: 369 x 79 x 87 mm (14-1/2 x 3-1/8 x 3-7/16")
Net weight	1.2 - 1.6 kg (2.6 - 3.5 lbs.)



Socket Adapter, Battery, Charger, Tool Bag, Z: Battery and Charger are sold separately

## WR100DSAek / DZ

9.5mm / 6.35mm (3/8 / 1/4") Cordless Ratchet Wrench

Compatible with variable sockets with socket adapter

Li-ion Ah 4.0 2.0 1.5



WR100DSAek



Capacity	Standard Bolt: M5 - M12 (3/16" - 1/2") High Tensile Bolt: M5 - M10 (3/16" - 3/8")
Square Drive	9.5 / 6.35 mm (3/8" / 1/4")
No Load Speed (RPM)	0 - 800
Max Fastening Torque	47.5 N-m (420 in.lbs.)
Dimensions (L x W x H)	w/ BL1016/BL1021B: 341x67x63 mm (13-7/16"x2-5/8"x2-1/2") w/ BL1041B: 341x67x84 mm (13-7/16"x2-5/8"x3-5/16")
Net weight	1.0 - 1.2 kg (2.3 - 2.7 lbs.)



Socket Adapter, Battery, Charger, Tool Bag, DZ: Battery and Charger are sold separately

## DTL063Z 9.5mm (3/8") Cordless Angle Impact Wrench

Compact angle head for easy access to bolts in tight places

Li-ion Ah 6.0 5.0 3.0 1.5



Fastening Capacities	Standard Bolt: M4 - M12 (5/32" - 1/2") High Tensile Bolt: M4 - M8 (5/32" - 5/16")
Square Drive	9.5 mm (3/8")
No Load Speed (RPM)	0 - 2,000
Impacts Per Minute (IPM)	0 - 3,000
Max Fastening Torque	60 N-m
Sound Power Level	99 dB(A)
Dimensions (L x W x H)	387x78x116 mm (15-1/4"x3-1/16"x4-9/16")
Net weight	1.4 - 2.0 kg (3.1 - 4.3 lbs)



Z: Battery and Charger are sold separately

## TL065DZ 9.5mm (3/8") Cordless Angle Impact Wrench

12Vmax CXT Li-Ion Cordless 60 N-m (530 in.lbs.) Angle Impact Wrench

Li-ion Ah 4.0 2.0 1.5



Capacity	Standard Bolt: M4 - M12 (5/32" - 1/2") High Tensile Bolt: M4 - M8 (5/32" - 5/16")
No Load Speed (RPM)	0 - 2,000
Impacts Per Minute (IPM)	0 - 3,000
Max Fastening Torque	60 N-m (530 in.lbs.)
Dimensions (L x W x H)	361x66x86 mm (14-1/4"x2-5/8"x3-3/8")
Net Weight	1.2 - 1.6 kg (2.7 - 3.6 lbs)



Belt Clip, Battery, Charger, DZ: Battery and Charger are sold separately



## DWT310PG2 / ZK Cordless Shear Wrench

High-speed fastening beyond AC tool

Li-ion Ah 6.0 5.0 3.0 1.5



Capacity	Bolt: M16, M20, M22 (5/8"; 3/4"; 7/8")
No Load Speed (RPM)	14
Max Fastening Torque	804 N-m (593 ft.lbs.)
Sound Power Level	94 dB(A)
Dimensions (L x W x H)	296x130x377 mm (11-5/8"x5-1/8"x14-7/8")
Net weight	6.5 - 7.1 kg (14.3 - 15.7 lbs.)



Screwdriver, Battery, Fast Charger, Z: Battery and Charger are sold separately



IMPACT WRENCH / SCREWDRIVER

6924N M22 (7/8"), M24 (1"), SHTB22 Shear Wrench

Shear Wrench for tightening M24 (1") torque shear bolt

303



Continuous Rating Input Capacity	1,050W Bolt : M22, M24, 7/8", 1" Super high tensile bolt: M22
No Load Speed (RPM)	19
Max Fastening Torque	1,100 N-m (810 ft.lbs.)
Dimensions (L x W x H)	330x104x257mm (13"x4-1/8"x10-1/8")
Net Weight	7.5kg (16.5lbs)
Power Supply Cord	2.5m (8.2ft)



Screwdriver

6922NB M16 (5/8"), M20 (3/4"), M22 (7/8") Shear Wrench

Delivers 804 N-m (593 ft.lbs.) of max torque

411



Continuous Rating Input Capacity	1,330W Bolt : M16, M20, M22 (5/8"; 3/4"; 7/8")
No Load Speed (RPM)	18
Max Fastening Torque	804 N-m (593 ft.lbs.)
Dimensions (L x W x H)	249x84x252mm (9-13/16"x3-5/16"x9-15/16")
Net Weight	4.9 kg (10.8 lbs)
Power Supply Cord	2.5m (8.2ft)



Screwdriver

PRODUCTS



SCREWDRIVER

DFS251RTE Cordless Screwdriver

Suitable for self drilling screw applications

Li-ion Ah 6.0 5.0 3.0 1.5



DFS251RTE



Capacity	Self-Drilling Screw: 6 mm (1/4") Drywall Screw: 5 mm (3/16") Hex Socket Screw: 6 mm (1/4")
Driving Shank (Hex)	6.35 mm (1/4")
No Load Speed (RPM)	0 - 2,500
Dimensions (L x W x H)	237x79x259 mm (9-3/8"x3-1/8"x11-1/4")
Net weight	1.5 - 1.8 kg (3.2 - 3.9 lbs)

18V



LXT BL

Magnetic Socket Bit, Battery, Fast Charger, Z: Battery and Charger are sold separately

FS2500 Screwdriver

Best possible tool body for screwdriving

419



Continuous Rating Input Capacity	570W Drywall screw: 5mm (3/16") Self-Drilling Screw: 6mm (1/4")
Driving Shank (Hex)	6.35mm (1/4")
No Load Speed (RPM)	0-2,500
Sound Power Level	94 dB(A)
Dimensions (L x W x H)	280x70x207mm (11"x2-3/4"x8-1/8")
Net Weight	1.5kg (3.3lbs)
Power Supply Cord	2.5m (8.2ft)

Dimensions: for countries providing noise suppressor



Magnetic Socket Bit

FS2700 Screwdriver

6 Stage torque adjustment for a wide range of applications

419



Continuous Rating Input Capacity	570W Machine screw: 8mm (5/16") Wood screw: 6.2mm (1/4") Self-Drilling Screw: 6mm (1/4")
Driving Shank (Hex)	6.35mm (1/4")
No Load Speed (RPM)	0-2,500
Sound Power Level	94 dB(A)
Dimensions (L x W x H)	301x70x207mm (11-7/8"x2-3/4"x8-1/8")
Net Weight	1.8kg (4.0lbs)
Power Supply Cord	2.5m (8.2ft)

Dimensions: for countries providing noise suppressor



Phillip Insert Bit

FS4300 Drywall Screwdriver

Silent clutch for quiet operation

419



Continuous Rating Input Capacity	570W Drywall screw: 5mm (3/16") Self-Drilling Screw: 6mm (1/4")
Driving Shank (Hex)	6.35mm (1/4")
No Load Speed (RPM)	0-4,000
Sound Power Level	93 dB(A)
Dimensions (L x W x H)	279x65x207mm (11"x2-9/16"x8-1/8")
Net Weight	1.4kg (3.1lbs)
Power Supply Cord	2.5m (8.2ft)

Dimensions: for countries providing noise suppressor and connect bit 60



Phillips Insert Bit (2pcs.), Magnetic Bit Holder

PRODUCTS

# MIXER

## DUT130RTE / Z Cordless Mixer

Variable 2-Speed Mixer

Li-ion 6.0 5.0 3.0 1.5



Blade Diameter	165 mm (6-1/2")
No Load Speed (RPM)	High / Low: 0 - 1,300 / 0 - 350
Shank Size Of Tool Holder Portion	M12 or M14
Dimensions (L x W x H)	w/ Mixing Blade: 916x89x231 mm (36"x3-1/2"x9-1/8") w/o Mixing Blade: 320x89x231 mm (12-5/8"x3-1/2"x9-1/8")
Net Weight	2.6kg (5.7lbs) 2.5 - 2.8 kg (5.6 - 6.3 lbs.)

DUT130RTE / Z



18V



Mixing Blade, Shaft, Shaft Holder (country-specific), Grip, Front Cover, Wrenches, Battery, Charger, Z: Battery and Charger are sold separately

## UT1301 Power Mixer

Ideal for stirring of resin, paints and adhesives at high speeds

106



Continuous Rating Input	700W
Blade Diameter	130 mm (5-1/8")
No Load Speed (RPM)	1,300
Overall Length	820 mm (32-1/4")
Net Weight	3.6 kg (7.9 lbs)
Power Supply Cord	2.5 m (8.2 ft)



Mixing Blade, Hex Wrench, Wrench

## Mixing at any place



### Mixer run time

# 25 min

Blade: 165mm Battery: BL1850B  
Material: One liquid paint 4L  
Rotation mode: Hi speed mode

Photo: DUT130

#### Battery cover



prevents concrete to be scattered on the battery

Stainless Steel Shaft  
to avoid rust  
DUT130 only

Blade Diameter:  
165mm  
DUT130 only

**Mechanical 2-speed**  
(0-350 & 0-1,300 RPM)



For a wide range of applications

**Rear Handle with Soft Rubber Grip**



Ergonomically designed for comfortable operation



**UT1305 Mixer**

850W Heavy duty and high speed mixer

303

**110V**

**UT1305/B**



Continuous Rating Input	850W
Blade Diameter	165 mm (6-1/2")
No Load Speed (RPM)	1,300
Shank Size Of Tool	M12
Holder Portion	
Dimensions (L x W x H)	942x87x152mm (37"x3-7/16"x6")
Net Weight	2.6kg (5.7lbs)
Power Supply Cord	2.5m (8.2ft)



Wrenches, Side Grip, Mixing Blade, Shaft

**UT2204/B Mixer**

Heavy duty and high torque mixer

303

**110V**

**UT2204/B**



Continuous Rating Input	850W
Blade Diameter	220 mm (8-5/8")
No Load Speed (RPM)	550
Shank Size Of Tool	M12 or M14
Holder Portion	
Dimensions (L x W x H)	929x89x152mm (36-1/2"x3-1/2"x6")
Net Weight	2.7kg (5.9lbs)
Power Supply Cord	2.5m (8.2ft)



Wrenches, Side Grip

**PRODUCTS**

**STATIONARY DRILL**

**HB500 50mm (2") Magnetic Drill**

Heavy duty Magnetic Drill

EIB106C

**110V**

**HB500/B**



Capacity	Steel: 50 mm (2")
Chuck Capacity	16mm (5/8")
No Load Speed (RPM)	350 / 650
Magnetic Clamping Force	Minimum 9,300N (950kg)
Dimensions (L x W x H)	290x150x450mm (11-3/8"x5-7/8"x17-3/4")
Net Weight	18.5kg



Quick release arbor, Small oil cup assembly and clip, Safety guard, Polyester safety strap, Integral oil feed steady allen keys

**HB350 35mm (1-3/8") Magnetic Drill**

Compact and lightweight for easy transport

UD00EBD002

**New**



Continuous Rating Input	1,050W
Capacity	Steel: 35 mm (1-3/8")
No Load Speed (RPM)	850
Magnetic Clamping Force	8,000 N
Dimensions (L x W x H)	270 x 110 x 330 mm
Net Weight	11.5 kg



Small oil cup assembly and clip, Safety guard, Polyester safety strap, Allen keys



**TB131 13mm (1/2") Drilling Machine 13mm**

Compact drilling machine



Continuous rating input	250W
Capacity	Steel: 13mm (1/2") Wood: 24mm (15/16")
No Load Speed (RPM)	570, 890, 1,300, 1,900, 2,670 (50Hz), 690, 1,070, 1,560, 2,280, 3,200 (60Hz)
Net weight	20kg (44lbs)
Power supply cord	1.75m (5.7ft)



Chuck Key, Wrench

PRODUCTS

# ROTARY HAMMER

## HR006GZ(K) 52mm (2-1/16") Cordless Rotary Hammer

Powerful BL motor delivers 20 J of impact energy

Li-ion Ah 8.0 5.0 4.0 2.5 2.0



Impact Energy	EPTA-Procedure 05/2009: 21.4 J
Capacity	Concrete (w/ TCT Bit): 52 mm
Blows Per Minute (BPM)	1,100 - 2,250
No Load Speed (RPM)	150 - 310
Max Output	2,600 W
Dimensions (L x W x H)	w/ BL4040: 610 x 140 x 337 mm (24 x 5-1/2 x 13-1/4")
Net weight	12.9 - 14.3 kg (28.4 - 31.5 lbs.)

40Vmax x2



Side Handle, Side Grip, Depth Gauge, Grease vessel, Z: Battery and Charger are sold separately

## HR005GM201(RM2K) / GZ(K) 40mm (1-9/16") Cordless Rotary Hammer

8.0 Joules (EPTA) Impact Energy Delivers High Performance

Li-ion Ah 8.0 5.0 4.0 2.5 2.0



Impact Energy	EPTA-Procedure 05/2009: 8 J
Capacity	Concrete (w/ TCT Bit): 40 mm
Blows Per Minute (BPM)	1,450 - 2,900
No Load Speed (RPM)	250 - 500
Sound Power Level	102 dB(A)
Vibration Level	Hammer Drilling into Concrete: 5.0 m/s <sup>2</sup>
Dimensions (L x W x H)	w/ BL4025: 484 x 115 x 286 mm w/ BL4040: 500 x 115 x 286 mm
Net weight	7.4 - 8.2 kg (16.3 - 18.1 lbs.)

40Vmax



Side Handle, Side Grip, Depth Gauge, Bit Grease, Cloth, Wireless Unit (country-specific), Wireless Unit Adapter (country-specific), Battery, Charger, Z: Battery and Charger are sold separately

## HR008GM201(RM2K) / GZ 30mm (1-3/16") Cordless Combination Hammer

New

Cordless 30 mm (1-3/16") Combination Hammer, SDS-PLUS Bits, Quick Change Drill Chuck

Li-ion Ah 8.0 5.0 4.0 2.5 2.0



Impact Energy	EPTA-Procedure: 3.9 J
Capacity	Concrete / Steel / Wood / Core Bit / Diamond Core Bit (Dry Type): 30 / 13 / 32 / 80 / 80 mm (1-3/16 / 1/2 / 1-1/4 / 3-1/8 / 3-1/8")
Blows Per Minute (BPM)	0 - 4,500
No Load Speed (RPM)	0 - 840
Chuck Capacity	1.5 - 13 mm (1/16 - 1/2")
Dimensions (L x W x H)	w/ BL4040: 422 x 103 x 242 mm (16-5/8 x 4-1/16 x 9-1/2")
Net weight	5.2 - 6.2 kg (11.5 - 13.7 lbs.)

40Vmax



Side Grip, Depth Gauge, Battery, Charger, Z: Battery and Charger are sold separately

## HR009GM201(RM2K) / GZ 30mm (1-3/16") Cordless Combination Hammer

New

Cordless 30 mm (1-3/16") Combination Hammer, SDS-PLUS Bits, Quick Change Drill Chuck

Li-ion Ah 8.0 5.0 4.0 2.5 2.0



Impact Energy	EPTA-Procedure: 3.9 J
Capacity	Concrete / Steel / Wood / Core Bit / Diamond Core Bit (Dry Type): 30 / 13 / 32 / 80 / 80 mm (1-3/16 / 1/2 / 1-1/4 / 3-1/8 / 3-1/8")
Blows Per Minute (BPM)	0 - 4,500
No Load Speed (RPM)	0 - 840
Chuck Capacity	1.5 - 13 mm (1/16 - 1/2")
Dimensions (L x W x H)	w/ BL4040: 422 x 103 x 242 mm (16-5/8 x 4-1/16 x 9-1/2")
Net weight	5.2 - 6.2 kg (11.5 - 13.7 lbs.)

40Vmax



Quick Change Drill Chuck, Side Grip, Depth Gauge, Battery, Charger, Z: Battery and Charger are sold separately

## HR001GM201(RM2J) / GD201(RD2J) / GZ 28mm (1-1/8") Cordless Combination Hammer

Excellent tool balance for easy handling and control

Li-ion Ah 8.0 5.0 4.0 2.5 2.0



Impact Energy	EPTA-Procedure 05/2009: 2.8 J
Capacity	Concrete / Steel / Wood / Core Bit / Diamond Core Bit (Dry Type): 28 / 13 / 32 / 54 / 65 mm
Blows Per Minute (BPM)	0 - 5,000
No Load Speed (RPM)	0 - 980
Dimensions (L x W x H)	w/ BL4025: 358 x 102 x 232 mm (14-1/8" x 4" x 9-1/8") w/ BL4040: 373 x 102 x 238 mm (14-3/4" x 4" x 9-3/8")
Net weight	3.9 - 4.6 kg

40Vmax



Side Grip, Depth Gauge, Battery, Charger, Wireless Unit (country-specific), Dust Cup (country-specific), Cleaning cloth (country-specific), Bit Grease (country-specific), Z: Battery and Charger are sold separately

## HR002GM201(RM2J) / GD201(RD2J) / GZ 28mm (1-1/8") Cordless Combination Hammer

Excellent tool balance for easy handling and control

Li-ion Ah 8.0 5.0 4.0 2.5 2.0



Impact Energy	EPTA-Procedure 05/2009: 2.9 J
Capacity	Concrete / Steel / Wood / Core Bit / Diamond Core Bit (Dry Type): 28 / 13 / 32 / 54 / 65 mm
Blows Per Minute (BPM)	0 - 5,000
No Load Speed (RPM)	0 - 980
Dimensions (L x W x H)	w/ BL4025: 389 x 102 x 232 mm (15-1/4" x 4" x 9-1/8") w/ BL4040: 404 x 102 x 238 mm (15-7/8" x 4" x 9-3/8")
Net weight	4.1 - 4.6 kg

40Vmax



Side Grip, Depth Gauge, Battery, Charger, Wireless Unit (country-specific), Dust Cup (country-specific), Cleaning cloth (country-specific), Bit Grease (country-specific), Z: Battery and Charger are sold separately



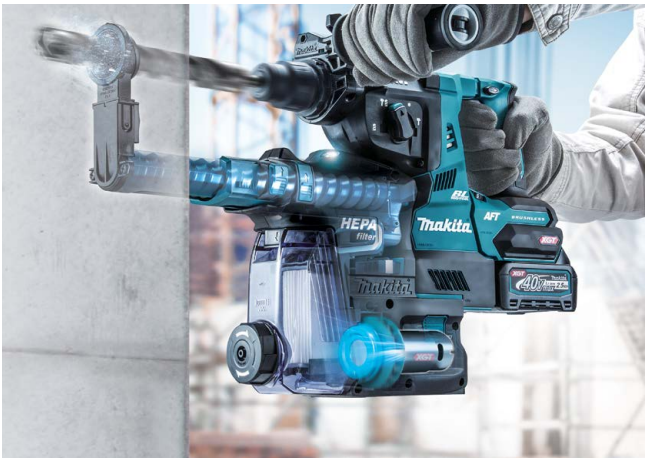

**HR003GM201 (RM2J) / GD201 (RD2J) / GZ**  
28mm (1-1/8") Cordless Combination Hammer

Anti-Vibration Technology (AVT) for extremely low vibration

Li-ion Ah	8.0	5.0	4.0	2.5	2.0
-----------	-----	-----	-----	-----	-----

HR003GM201 / GD201

1

HR003GZ

2

Impact Energy Capacity	EPTA-Procedure 05/2009: 2.8 J Concrete / Steel / Wood / Core Bit / Diamond Core Bit (Dry Type): 28 / 13 / 32 / 54 / 65 mm
Blows Per Minute (BPM)	0 - 5,000
No Load Speed (RPM)	0 - 980
Dimensions (L x W x H)	w/ BL4025: 358x121x232mm (14-1/8"x4-3/4"x9-1/8") w/ BL4040: 373x102x238mm (14-3/4"x4"x9-3/8")
Net weight	3.9 - 4.6kg

**40Vmax** **XGT BL AVT XPT**

Side Grip, Depth Gauge, Battery, Charger, Wireless Unit (country-specific), Dust Cup (country-specific), Cleaning cloth (country-specific), Bit Grease (country-specific), Z: Battery and Charger are sold separately

**HR004GM201 (RM2J) / GZ**  
28mm (1-1/8") Cordless Combination Hammer

Anti-Vibration Technology (AVT) for extremely low vibration

Li-ion Ah	8.0	5.0	4.0	2.5	2.0
-----------	-----	-----	-----	-----	-----

HR004GM201

1

HR004GZ

2

Impact Energy Capacity	EPTA-Procedure 05/2009: 2.9 J Concrete / Steel / Wood / Core Bit / Diamond Core Bit (Dry Type): 28 / 13 / 32 / 54 / 65 mm
Blows Per Minute (BPM)	0 - 5,000
No Load Speed (RPM)	0 - 980
Dimensions (L x W x H)	w/ BL4025: 389x102x232mm (15-1/4"x4"x9-1/8") w/ BL4040: 404x102x238mm (15-7/8"x4"x9-3/8")
Net weight	4.0 - 4.5 kg

Quick change drill chuck

**40Vmax** **XGT BL AVT XPT**

Side Grip, Depth Gauge, Battery, Charger, Wireless Unit (country-specific), Dust Cup (country-specific), Cleaning cloth (country-specific), Bit Grease (country-specific), Z: Battery and Charger are sold separately

**HR007GM201 (RM2J) / GZ**  
28mm (1-1/8") Cordless Combination Hammer

Cordless 28mm D-handle combination hammer

Li-ion Ah	8.0	5.0	4.0	2.5	2.0
-----------	-----	-----	-----	-----	-----

HR007GM201

1

Impact Energy Capacity	EPTA-Procedure 05/2009: 3.0 J Concrete / Steel / Wood / Core Bit / Diamond Core Bit (Dry Type): 28 / 13 / 32 / 54 / 65 mm
Blows Per Minute (BPM)	0 - 5,000
No Load Speed (RPM)	0 - 980
Vibration Level	Hammer Drilling into Concrete: 7.5 m/s <sup>2</sup> Chiselling Function w/ Side Grip: 8.6 m/s <sup>2</sup> Drilling into Metal: 2.8 m/s <sup>2</sup>
Dimensions (L x W x H)	w/ BL4040: 473 x 101 x 240 mm (18-5/8 x 4 x 9-1/2")
Net weight	3.8 - 4.8 kg (8.4 - 10.6 lbs.)

**40Vmax** **XGT BL AFT AWS AVT XPT**

Side Grip, Depth Gauge, Battery, Charger, Cloth, Grease vessel, Z: Battery and Charger are sold separately

**Dust Extraction System**

**HEPA filter**

HR007G + DX15 (191X39-9)

HR001G + DX12 (191E52-3)	HR002G + DX14 (191E58-1)
HR008G + DX10 (191F95-1)	HR009G + DX11 (191G00-4)
DHR282 + DX08 (199579-7)	DHR283 + DX09 (199583-6)



**DHR400G2N / ZKN 40mm (1-9/16") Cordless Rotary Hammer**

High Power similar to AC Tool

Li-ion Ah	6.0	5.0	3.0	1.5
-----------	-----	-----	-----	-----

DHR400G2N

1

Impact Energy Capacity	EPTA-Procedure 05/2009: 8.0 J experimental conditions 11.4 J Concrete (w/T.C.bit): 40 mm Concrete (w/Core bit): 105 mm
Blows Per Minute (BPM)	1,450 - 2,900
No Load Speed (RPM)	250 - 500
Sound Power Level	102 dB(A)
Dimensions (L x W x H)	473x120x285 mm (18-5/8"x4-3/4"x11-1/4")
Net weight	7.3 - 8.1 kg (16.1 - 17.9 lbs)

**18V x2** **LXT BL AFT AWS AVT SOLID XPT**

Side Handle, Side Grip, Depth Gauge, Bit Grease, Cloth, Wireless Unit, Battery, Fast Charger, Z: Battery and Charger are sold separately

Items of standard equipment and specifications may vary by country or area. Net weight and dimensions may differ by the type of battery.

**DHR280PG2J / PF2J / ZJ**  
28mm (1-1/8") Cordless Combination Hammer

High speed drilling and great work volume

Li-ion Ah 6.0 5.0 3.0 1.5



Impact Energy Capacity	EPTA-Procedure 05/2009:2.8J Concrete/Steel/Wood/Core Bit/ Diamond Core Bit (Dry Type): 28/13/32/54/65 mm (1-1/8"/1/2"/1-1/4"/2-1/8"/2-9/16")
Blows Per Minute (BPM)	0 - 5,000
No Load Speed (RPM)	0 - 980
Sound Power Level	104 dB(A)
Dimensions (L x W x H)	373x134x232 mm (14-3/4"x5-1/4"x9-1/8")
Net weight	3.9-4.9kg(8.6-10.8lbs)

18V x2



Side Grip, Depth Gauge, Battery, Fast Charger, Dust Cup, Cleaning cloth, Bit Grease, Z: Battery and Charger are sold separately

**DHR281PG2J / ZJ**  
28mm (1-1/8") Cordless Combination Hammer

High speed drilling and great work volume

Li-ion Ah 6.0 5.0 3.0 1.5



Impact Energy Capacity	EPTA-Procedure 05/2009:2.8J Concrete/Steel/Wood/Core Bit/ Diamond Core Bit (Dry Type): 28/13/32/54/65 mm (1-1/8"/1/2"/1-1/4"/2-1/8"/2-9/16")
Blows Per Minute (BPM)	0 - 5,000
No Load Speed (RPM)	0 - 980
Sound Power Level	103 dB(A)
Dimensions (L x W x H)	404x134x232 mm (15-7/8"x5-1/4"x9-1/8")
Net weight	4.0-5.1kg(8.8-11.2lbs)

18V x2



Quick Change Drill Chuck, Side Grip, Depth Gauge, Battery, Fast Charger, Dust Cup, Cleaning cloth, Bit Grease, Z: Battery and Charger are sold separately

**DHR282PG2J / ZJ**  
28mm (1-1/8") Cordless Combination Hammer

High speed drilling and great work volume

Li-ion Ah 6.0 5.0 3.0 1.5



Impact Energy Capacity	EPTA-Procedure 05/2009:2.8J Concrete/Steel/Wood/Core Bit/ Diamond Core Bit (Dry Type): 28/13/32/54/65 mm (1-1/8"/1/2"/1-1/4"/2-1/8"/2-9/16")
Blows Per Minute (BPM)	0 - 5,000
No Load Speed (RPM)	0 - 980
Sound Power Level	104 dB(A)
Dimensions (L x W x H)	373x134x232 mm (14-3/4"x5-1/4"x9-1/8")
Net weight	3.9-5.0kg(8.6-11.0lbs)

18V x2



Side Grip, Depth Gauge, Battery, Fast Charger, Dust Cup, Cleaning cloth, Bit Grease, Z: Battery and Charger are sold separately

**DHR283PG2J / ZJ**  
28mm (1-1/8") Cordless Combination Hammer

High speed drilling and great work volume

Li-ion Ah 6.0 5.0 3.0 1.5



Impact Energy Capacity	EPTA-Procedure 05/2009:2.8J Concrete/Steel/Wood/Core Bit/ Diamond Core Bit (Dry Type): 28/13/32/54/65 mm (1-1/8"/1/2"/1-1/4"/2-1/8"/2-9/16")
Blows Per Minute (BPM)	0 - 5,000
No Load Speed (RPM)	0 - 980
Sound Power Level	103 dB(A)
Dimensions (L x W x H)	404x134x232 mm (15-7/8"x5-1/4"x9-1/8")
Net weight	4.1-5.1kg(9.0-11.2lbs)

18V x2



Quick Change Drill Chuck, Side Grip, Depth Gauge, Battery, Fast Charger, Dust Cup, Cleaning cloth, Bit Grease, Z: Battery and Charger are sold separately

Under load

**AVT**  
ANTI VIBRATION TECHNOLOGY

Active dynamic vibration absorber

- ensures operation with extremely low vibration.
- allows tool design with flat body sides for better handling

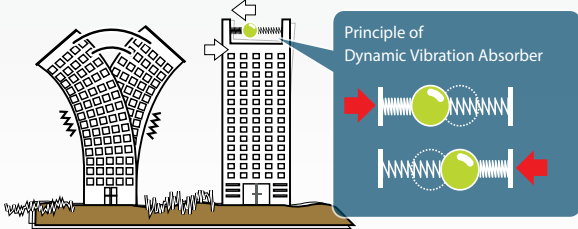
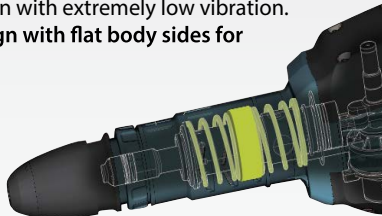

During no-load

**SOFT NOLOAD**

Suppression of motor speed

- reduces vibration of tool body when idling, accordingly decreases the amount of vibration to operator's hands during a day's operation
- minimizes deflection of bit tip from aiming point when starting chipping

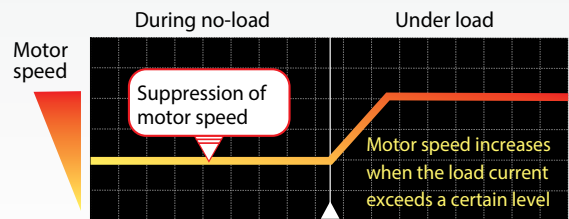



**DHR242RTE / Z** 24mm (15/16") Cordless Combination Hammer

Efficient Brushless DC motor provides higher productivity

Li-ion Ah 6.0 5.0 3.0 1.5



DHR242RTE / Z



Impact Energy	2 J
Capacity	Concrete: 24 mm (15/16") Steel: 13 mm (1/2") Wood: 27 mm (1-1/16")
Impacts Per Minute (IPM)	0-4,700
No Load Speed (RPM)	0-950
Sound Power Level	101 dB(A)
Dimensions (L x W x H)	328x85x213mm (12-7/8"x3-3/8"x8-3/8")
Net weight	3.1 - 3.8 kg (6.7 - 8.4 lbs)

18V



Fast Charger, Battery Cartridge, Depth Gauge, Side Grip, Z: Battery and Charger are sold separately (Tool does not come with bit)

**DHR202RTE / Z** 20mm (13/16") Cordless Combination Hammer

40 different chisel positions for increased comfort and performance

441

Li-ion Ah 6.0 5.0 3.0 1.5



Capacity	Concrete: 20 mm (13/16") Steel: 13 mm (1/2") Wood: 26 mm (1")
Impacts Per Minute (IPM)	0-4,000
No Load Speed (RPM)	0 - 1,100
Sound Power Level	101 dB(A)
Dimensions (L x W x H)	358 x 84 x 259 mm (14-1/8 x 3-5/16 x 10-1/4")
Net weight	3.2 - 4 kg (7.1 - 8.8 lbs.)

18V



Charger, Battery, Side Grip, Depth Gauge

**DHR182RGJ / RFJ / Z** 18mm (11/16") Cordless Rotary Hammer

BL Motor Delivers 0-1,350 RPM, 0-5,000 BPM and 1.7 Joules of Impact Energy

Li-ion Ah 6.0 5.0 3.0 1.5



DHR182Z



DHR182RGJ / RFJ



Impact Energy	EPTA-Procedure 05/2009: 1.7 J
Capacity	Concrete: 18 mm (11/16") Steel: 13 mm (1/2") Wood: 24 mm (15/16")
Blows Per Minute (BPM)	0 - 5,000
No Load Speed (RPM)	0 - 1,350
Dimensions (L x W x H)	w/ BL1830B / BL1840B / BL1850B / BL1860B: 301x82x285 mm (11-7/8"x3-1/4"x11-1/4")
Net weight	2.4 - 3.2 kg (5.3 - 7.0 lbs.)

18V



Dust Cup (country-specific), Side Grip, Depth Gauge, Battery, Fast Charger, Z: Battery and Charger are sold separately

**DHR171RTJ / Z** 17mm (11/16") Cordless Rotary Hammer

Compact and lightweight for reduced operator fatigue

Li-ion 6.0 5.0 3.0 1.5



DHR171RTJ



Impact Energy	Our experimental conditions: 1.1 J
Capacity	Concrete: 17 mm (11/16") Steel: 10 mm (3/8") Wood: 13 mm (1/2")
Blows Per Minute (BPM)	0 - 4,800
No Load Speed (RPM)	0 - 680
Sound Power Level	97 dB(A)
Dimensions (L x W x H)	with BL1830B / BL1840B / BL1850B / BL1860B: 273x86x211mm (10-3/4"x3-3/8"x8-5/16")
Net weight	2.1 - 2.8 kg (4.6 - 6.2 lbs)

18V



Dust Cup (country-specific), Side Grip, Depth Gauge, Battery, Fast Charger, Z: Battery and Charger are sold separately



**HR166DSAE1 / DZ** 16mm (5/8") Adapted for SDS-PLUS bits

12Vmax CXT BL Brushless Cordless 16 mm (5/8") Rotary Hammer, SDS-PLUS Bits

Li-ion Ah 4.0 2.0 1.5



HR166DSAE1

HR166DSAE1 HR166DZ



Impact Energy	1.1 J
Capacity	Concrete: 16 mm (5/8") Steel: 10 mm (3/8") Wood: 13 mm (1/2")
Blows Per Minute (BPM)	0 - 4,800
No Load Speed (RPM)	0 - 680
Sound Power Level	97 dB(A)
Dimensions (L x W x H)	250x74x187 mm (9-7/8"x2-15/16"x7-3/8")
Net Weight	1.8 - 2.4kg (4.1 - 5.4lbs)

12Vmax



Battery, Charger, DZ: Battery and Charger are sold separately

**HR1840J** 18mm (11/16") Rotary Hammer

2-Mode operation for "Rotation Only" or "Hammering with Rotation"

459



Continuous Rating Input	470W
Capacity	Our experimental conditions: 1.4 J Concrete (with T.C.T. bit): 18 mm (11/16") Steel: 13 mm (1/2") Wood: 24 mm (15/16")
Blows Per Minute (BPM)	0 - 4,800
No Load Speed (RPM)	0 - 1,900
Dimensions (L x W x H)	285x75x208mm (11-1/4"x3"x8-3/16")
Net Weight	2.0 - 2.4 kg (4.3 - 5.3 lbs.)

2 modes



Depth Gauge, Side Grip

**HR2020** 20mm (3/4") Rotary Hammer

Simple and solid construction, yet powerful performance

419



Continuous Rating Input	710W
Capacity	Concrete: 20 mm (3/4") Steel: 13 mm (1/2") Wood: 32 mm (1-1/4")
Blows Per Minute (BPM)	0 - 4,050
No Load Speed (RPM)	0 - 1,050
Overall Length	352 mm (13-7/8")
Net Weight	2.3 kg (5.1 lbs)
Power Supply Cord	2.5kg (8.2ft)

2 modes



Depth Gauge, Side Grip

## nemesis II drill bit for SDS-PLUS Hammers

# NEMESIS II



- \*One piece solid carbide tip (5-10mm)
- \*No seizing up on hitting reinforcing steel
- \*Ensure precision drill holes
- \*Drills more precisely
- \*Low vibration and high fracture resistance



Five-star range



## HR2470X5 24mm (15/16") Combination Hammer

High durability in mechanical parts, motor and carbon brush

325



Continuous Rating Input	780W
Capacity	Concrete: 24 mm (15/16") Core Bit: 54 mm (2-1/8") Steel: 13 mm (1/2") Wood: 32 mm (1-1/4")
Blows Per Minute (BPM)	0 - 4,500
No Load Speed (RPM)	0 - 1,100
Sound Power Level	101 dB(A)
Dimensions (L x W x H)	370x84x214 mm (14-1/2"x3-5/16"x8-3/8")
Net Weight	2.9-3.3kg (6.4-7.3lbs)
Power Supply Cord	2.5kg (8.2ft)

110V

HR2470X5/B



Side Handle, Depth Gauge, Quick Change Drill Chuck, SDS-Plus Bit Set (country-specific), Bull Point (country-specific)(HR2470FT), Scaling Chisel (country-specific) (HR2470T)

## HR2300 23mm (7/8") Rotary Hammer

Easy-to-grip handle ergonomically designed to give maximum power thrust

325



Continuous Rating Input	720W
Capacity	Concrete: 23 mm (7/8") Steel: 13 mm (1/2") Wood: 32 mm (1-1/4")
Blows Per Minute (BPM)	0-4,600
No Load Speed (RPM)	0-1,200
Sound Power Level	101 dB(A)
Dimensions (L x W x H)	356x77x209mm (14"x3"x8-1/4")
Net Weight	2.7 - 3.1kg (5.9 - 6.9lbs)
Power Supply Cord	2.5kg (8.2ft)

110V

HR2300/B



Side Grip, Depth Gauge (Tool does not come with bit)

## HR2470X5 24mm (15/16") Combination Hammer

High durability in mechanical parts, motor and carbon brush

325



Continuous Rating Input	780W
Capacity	Concrete: 24 mm (15/16") Core Bit: 54 mm (2-1/8") Steel: 13 mm (1/2") Wood: 32 mm (1-1/4")
Blows Per Minute (BPM)	0 - 4,500
No Load Speed (RPM)	0 - 1,100
Sound Power Level	101 dB(A)
Dimensions (L x W x H)	370x84x214 mm (14-1/2"x3-5/16"x8-3/8")
Net Weight	2.9-3.3kg (6.4-7.3lbs)
Power Supply Cord	2.5kg (8.2ft)

110V

HR2470X5/B



Side Handle, Depth Gauge, Quick Change Drill Chuck, SDS-Plus Bit Set (country-specific), Bull Point (country-specific)(HR2470FT), Scaling Chisel (country-specific) (HR2470T)

## HR2600 26mm (1") Rotary Hammer

Easy-to-grip handle ergonomically designed to give maximum power thrust

325



Continuous Rating Input	800W
Capacity	Concrete (w/TCT Bit): 26 mm (1") Steel: 13 mm (1/2") Wood: 32 mm (1-1/4")
Blows Per Minute (BPM)	0 - 4,600
No Load Speed (RPM)	0 - 1,200
Sound Power Level	102 dB(A)
Dimensions (L x W x H)	361x77x209mm (14-1/4"x3"x8-1/4")
Net Weight	3 - 3.4kg (6.5 - 7.5lbs)
Power Supply Cord	2.5m (8.2ft)

2 modes



Side Grip, Depth Gauge (Tool does not come with bit)

## HR2630X3 26mm (1") Combination Hammer

26mm (1") Combination Hammer

325

110V

HR2630/B



Continuous Rating Input	800W
Capacity	Concrete: 26 mm (1") Core Bit: 68 mm (2-11/16") Diamond Core Bit (Dry Type): 80 mm (3-1/8") Steel: 13 mm (1/2") Wood: 32 mm (1-1/4")
Blows Per Minute (BPM)	0 - 4,600
No Load Speed (RPM)	0 - 1,200
Sound Power Level	101 dB(A)
Dimensions (L x W x H)	385x77x209 mm (15-1/8"x3"x8-1/4")
Net Weight	3.0 kg (6.6 lbs)
Power Supply Cord	2.5 m (8.2 ft)

Tool does not come with bit



Side Grip, Depth Gauge

HR2652X3 26mm (1")  
Combination Hammer with Self Dust Collection

New

Filter Cleaning Mechanism for More Efficient Drilling

325



Continuous rating input	800W
Impact Energy	EPTA-Procedure 05/2009: 2.2 J
Capacity	Concrete: 26 mm (1") Steel: 13 mm (1/2") Wood: 32 mm (1-1/4")
Blows Per Minute (BPM)	0 - 4,600
No Load Speed (RPM)	0 - 1,200
Dimensions (L x W x H)	604x89x260 mm (23-3/4"x3-1/2"x10-1/4")
Net weight	3.1 - 4.3 kg (6.9 - 9.6 lbs.)
Power supply cord	2.5 m (8.2 ft.)



Side grip, Depth Gauge, Sealing Cap

## HR2810 28mm (1-1/8") Combination Hammer

3 operation modes - hammering, hammering with rotation, rotation

325

110V

HR2810/B



Continuous Rating Input	800W
Capacity	Concrete (with T.C.T. bit): 28mm (1-1/8") Steel: 13 mm (1/2") Wood: 32 mm (1-1/4")
Blows Per Minute (BPM)	0-4,500
No Load Speed (RPM)	0-1,100
Sound Power Level	100 dB(A)
Dimensions (L x W x H)	314x89x225 mm (12-3/8"x3-1/2"x8-7/8")
Net Weight	3.4 - 3.8kg (7.5 - 8.5lbs)
Power Supply Cord	4.0 m (13.1 ft)

Tool does not come with bit



Side Grip, Depth Gauge





**HR3001CJ 30mm (1-3/16") Combination Hammer**

Drilling efficiency drastically increased by redesigned hammering mechanism **350** 



Continuous Rating Input	1,050W
Impact Energy	EPTA-Procedure 05/2009: 3.9 J Our experimental conditions: 4.5 J
Capacity	Concrete (w/ TCT Bit): 30 mm (1-3/16") Concrete (w/ Core Bit): 80 mm (3-1/8") Concrete (w/ Diamond Core Bit): 80 mm (3-1/8") Steel: 13 mm (1/2") Wood: 32 mm (1-1/4")
Blows Per Minute (BPM)	0 - 4,500
No Load Speed (RPM)	0 - 840
Dimensions (L x W x H)	369 x 98 x 226 mm
Net Weight	4.1 - 4.5 kg (9.0 - 9.9 lbs.)
Power Supply Cord	4.0 m (13.1 ft)

**3 modes**



Depth Gauge, Side Grip

**HR3011FCJ 30mm (1-3/16") Combination Hammer**

Powerful yet with low vibration due to 2 Counterweights **350** 



Continuous Rating Input	1,050W
Impact Energy	EPTA-Procedure 05/2009: 3.9 J Our experimental conditions: 4.5 J
Capacity	Concrete (w/ TCT Bit): 30 mm (1-3/16") Concrete (w/ Core Bit): 80 mm (3-1/8") Concrete (w/ Diamond Core Bit): 80 mm (3-1/8") Steel: 13 mm (1/2") Wood: 32 mm (1-1/4")
Blows Per Minute (BPM)	0 - 4,500
No Load Speed (RPM)	0 - 840
Dimensions (L x W x H)	369 x 98 x 242 mm
Net Weight	4.4 - 4.8 kg (9.7 - 10.6 lbs.)
Power Supply Cord	4.0 m (13.1 ft)

**3 modes**



Depth Gauge, Side Grip

**HR3200C 32mm (1-1/4") Combination Hammer**

3 operation modes - hammering, hammering with rotation, rotation **350** 



Continuous Rating Input	850W
Capacity	Concrete (with T.C.T. bit): 32mm (1-1/4") Steel: 13 mm (1/2") Wood: 32 mm (1-1/4")
Blows Per Minute (BPM)	1,650-3,300
No Load Speed (RPM)	315-630
Dimensions (L x W x H)	398x108x239 mm (15-5/8"x4-1/4"x9-3/8")
Net Weight	4.8 - 5.2kg (10.5 - 11.5 lbs)
Power Supply Cord	5.0m (16.4ft)

**3 modes**



Depth Gauge, Side Grip, Grease Vessel

**HR4003C 40mm (1-9/16") Rotary Hammer**

Most powerful and efficient in the class **350** 



Continuous Rating Input	1,100W
Capacity	Concrete (with T.C.T. bit): 40mm (1-9/16") Concrete (with Core bit): 105mm (4-1/8")
Blows Per Minute (BPM)	1,450 - 2,900
No Load Speed (RPM)	250-500
Dimensions (L x W x H)	479x106x263mm (18-11/16"x4-3/8"x10-3/8")
Net Weight	6.2kg (13.8lbs)
Power Supply Cord	5.0m (16.4ft)

**110V**

**HR4003C/B**

**2 modes**



Depth Gauge, Side Handle, Bit Grease

**HR4013C 40mm (1-9/16") Rotary Hammer**

High efficiency and unrivalled low level of vibration **350** 



Continuous Rating Input	1,100W
Capacity	Concrete (with T.C.T. bit): 40mm (1-9/16") Concrete (with Core bit): 105mm (4-1/8")
Blows Per Minute (BPM)	1,450 - 2,900
No Load Speed (RPM)	250 - 500
Dimensions (L x W x H)	479x112x263mm (18-11/16"x4-3/8"x10-3/8")
Net Weight	6.8 - 6.9kg (14.9 - 15.3lbs)
Power Supply Cord	5.0m (16.4ft)

**2 modes**

Tool does not come with bit



AVT SOFT ROTOR

Depth Gauge, Side Handle, Bit Grease

**HR4501C 45mm (1-3/4") Rotary Hammer**

High performance and durability **175** 



Continuous Rating Input	1,350W
Capacity	Concrete (with T.C.T. bit): 45mm (1-3/4") Concrete (with Core bit): 125mm (5")
Blows Per Minute (BPM)	1,250 - 2,750
No Load Speed (RPM)	130 - 280
Dimensions (L x W x H)	458x121x288mm (18"x4-3/4"x11-3/8")
Net Weight	8.2 - 8.4kg (18.1 - 18.5lbs)
Power Supply Cord	5.0m (16.4ft)

**2 modes**

Tool does not come with bit



Side Handle(D), Side Grip, Depth Gauge, Grease Vessel

**HR5202C 52mm (2-1/16") Rotary Hammer**

High efficiency and durability **175** 



Continuous Rating Input	1,510W
Capacity	Concrete (with T.C.T. bit): 52mm (2") Concrete (with Core bit): 160mm (6-5/16")
Blows Per Minute (BPM)	1,100 - 2,250
No Load Speed (RPM)	150 - 310
Sound Pressure Level	99 dB(A)
Sound Power Level	110 dB(A)
Dimensions (L x W x H)	599x134x287mm (23-1/2"x5-1/4"x11-1/4")
Net Weight	10.9 - 11.1kg (24.1-24.4lbs)
Power Supply Cord	5.0m (16.4ft)

**110V**

**HR5202C/B**

**2 modes**

Tool does not come with bit



Side handle (D), Side grip, Depth gauge, Grease vessel

**HR5212C 52mm (2-1/16") Rotary Hammer**

High efficiency and unrivalled low level of vibration **175** 



Continuous Rating Input	1,510W
Capacity	Concrete (with T.C.T. bit): 52mm (2") Concrete (with Core bit): 160mm (6-5/16")
Blows Per Minute (BPM)	1,100 - 2,250
No Load Speed (RPM)	150 - 310
Dimensions (L x W x H)	599x140x287mm (23-1/2"x5-1/2"x11-1/4")
Net Weight	11.9-12.0kg (26.2-26.5lbs)
Power Supply Cord	5.0m (16.4ft)

**2 modes**

Tool does not come with bit



AVT SOFT ROTOR

Side Handle (D), Side Grip, Depth Gauge, Grease Vessel

PRODUCTS

# DEMOLITION HAMMER

## DHK180RTJ / Z Cordless Power Scraper

18V LXT BL AVT Cordless Power Scraper, SDS-PLUS Bits

Li-ion Ah 6.0 5.0 3.0 1.5



DHK180RTJ / Z  
1

Impact Energy	EPTA-Procedure 05/2009: 3.1 J Our experimental conditions: 3.9 J
Blows Per Minute (BPM)	0 - 3,200
Vibration Level	Chiselling: 4.5 m/s <sup>2</sup>
Sound Pressure Level	83 dB(A)
Sound Power Level	94 dB(A)
Dimensions (L x W x H)	368x99x211 mm (14-1/2"x3-7/8"x8-5/16")
Net weight	3.3 - 3.6 kg (7.3 - 7.9 lbs.)

18V



Bull Point, Cold Chisel (country-specific), Scaling chisel (for tile), Hook, Battery, Charger, Z: Battery and Charger are sold separately

## HK1820 Power Scraper

Compact and lightweight. One-touch sliding chuck

350 mm



Continuous Rating Input	550W
Blows Per Minute (BPM)	0-3,200
Dimensions (L x W x H)	351x102x203 mm (13-3/4"x4"x8")
Net Weight	3.4kg (7.5lbs)
Power Supply Cord	5.0m (16.4ft)



Bull Point, Scaling Chisel, Scaling Chisel (For Tile), Hook Complete

## Excellent performance as AC power scraper

### 12 bit angle settings

Adjustable chisel angle allows for easy operation in various applications.



### Variable speed control by dial

enables to adjust scraping power to the material of subfloor/subwall.



### 1 High Power and High efficiency

BL motor delivers high power equivalent to AC models.



### Impact Energy

3.1 J

EPTA-Procedure 05/2009:

### 2 Vibration absorbing housing

The housing construction reduces vibration of the rear handle and the barrel portion.

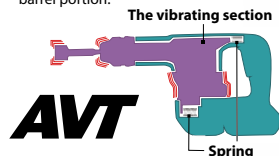

### Vibration Level

4.5 m/s<sup>2</sup>

Adapted for SDS-PLUS bits



Photo: DHK180

## HM002GZ03(K) Cordless Demolition Hammer

40Vmax X2 & BL motor for 20.0 J high power

Li-ion Ah 8.0 5.0 4.0 2.5 2.0



1

Impact Energy	EPTA-Procedure 05/2009: 20.9 J
Blows Per Minute (BPM)	950 - 1,900
Max Output	2,600W
Shank Diameter	18mm (11/16")
Dimensions (L x W x H)	w/BL4025: 574 x 146 x 324 mm (22-5/8 x 5-3/4 x 12-3/4") w/BL4040: 574 x 146 x 324 mm (22-5/8 x 5-3/4 x 12-3/4")
Net weight	12.0 - 13.3 kg (26.5 - 29.3 lbs.)

40Vmax x2



Grease for bit, Side Handle, Wireless Unit (country-specific), Wireless Unit Adapter (country-specific), Battery, Charger, Z: Battery and Charger are sold separately

## HM001GM204(RM2K) / GZ03(K) Cordless Demolition Hammer

High power and compact

Li-ion Ah 8.0 5.0 4.0 2.5 2.0



1

Impact Energy	EPTA-Procedure 05/2009: 9.4 J
Blows Per Minute (BPM)	0 - 2,650
Shank Diameter	18mm (11/16")
Sound Power Level	100 dB(A)
Dimensions (L x W x H)	w/BL4025: 481 x 113 x 258 mm (19 x 4-7/16 x 10-1/8") w/BL4040: 496 x 113 x 258 mm (19-1/2 x 4-7/16 x 10-1/8")
Net weight	6.3 - 7.1 kg (13.9 - 15.7 lbs.)

40Vmax



Bit Grease, Side Grip (country-specific), Wireless Unit (country-specific), Wireless Unit Adapter (country-specific), Cloth, Battery, Charger, Z: Battery and Charger are sold separately



# High power and Low vibration

Impact energy  
[EPTA-Procedure 05/2009]  
**20.9**  
Joule

Photo: HM002G



High power brushless motor

## AVT

Anti-Vibration Technology

Vibration level at main handle

**8.0** m/s<sup>2</sup>



## SOFT NOLOAD

Suppression of motor speed during no-load

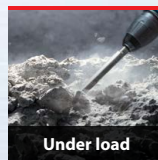
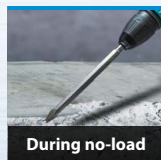

## AWS

Auto-start Wireless System



### HM0810A 17mm (11/16") Hex Shank Demolition Hammer

Perfect combination of power, durability and compact design

105

Continuous Rating Input	900W
Blows Per Minute (BPM)	2,900
Sound Power Level	103 dB(A)
Overall Length	410 mm (16-1/8")
Net Weight	6.7kg (14.7lbs)
Power Supply Cord	5.0m (16.4ft)



Bull Point, Hex Wrench, Side Grip

### HM0810TA 17mm (11/16") Hex Shank Demolition Hammer

Perfect combination of power, durability and compact design

105

Continuous Rating Input	900W
Blows Per Minute (BPM)	2,900
Sound Power Level	103 dB(A)
Overall Length	410 mm (16-1/8")
Net Weight	6.7kg (14.7lbs)
Power Supply Cord	5.0m (16.4ft)



110V

HM0810TA/B



Bull Point, Hex Wrench, Side Grip

### HM0870C Demolition Hammer

High durability and excellent demolition performance

350

Continuous Rating Input	1,100W
Blows Per Minute (BPM)	1,100-2,650
Sound Power Level	98 dB(A)
Dimensions (L x W x H)	449x109x230mm (17-3/4"x4-1/4"x9")
Net Weight	5.1-5.3kg (11.1-11.6lbs)
Power Supply Cord	5.0m (16.4ft)

Tool does not come with bull point



110V

HM0870C/B



Grease for Bit, Side Handle

### HM0871C Demolition Hammer

AVT (Anti-Vibration Technology) ensures extra-low vibration performance

350

Continuous Rating Input	1,100W
Blows Per Minute (BPM)	1,100-2,650
Sound Power Level	97 dB(A)
Vibration Level	Chiseling: 8.0 m/s <sup>2</sup>
Dimensions (L x W x H)	466x116x230mm (18-3/8"x4-9/16"x9")
Net Weight	5.6-5.8kg (12.4-12.8lbs)
Power Supply Cord	5.0m (16.4ft)

Tool does not come with bull point



Grease for Bit, Side Handle

## HM1205C Demolition Hammer

19.1 J Demolition Hammer, SDS-MAX Bits

175



Continuous Rating Input	1,510W
Blows Per Minute (BPM)	950 - 1,900
Dimensions (L x W x H)	576x128x265mm (22-3/4"x5" x10-3/8")
Net Weight	9.7kg (21.4lbs)
Power Supply Cord	5.0m (16.4ft)



Bull Point, Bit Grease, Side Handle

## HM1213C Demolition Hammer

AVT (Anti-Vibration Technology) ensures extra-low vibration performance

175



Continuous Rating Input	1,510W
Blows Per Minute (BPM)	950-1,900
Sound Power Level	95 dB(A)
Dimensions (L x W x H)	576x149x265mm (22-3/4"x5-7/8"x10-3/8")
Net Weight	10.8kg (23.6lbs)
Power Supply Cord	5.0m (16.4ft)



Bull Point, Bit Grease, Side Handle

## HM1214C Demolition Hammer

Comfortable operation at hammering downward

175



Continuous Rating Input	1,510W
Blows Per Minute (BPM)	950-1,900
Sound Power Level	98 dB(A)
Dimensions (L x W x H)	700x129x265mm (27-1/2"x5-1/8"x10-3/8")
Net Weight	12.3kg (27.1lbs)
Power Supply Cord	5.0m (16.4ft)



HM1214C/B



Bull Point, Bit Grease, Side Handle

## HM1306 30mm (1-3/16") Hex Shank Demolition Hammer

21.7 J Demolition Hammer, 30 mm Hex Shank

204



Continuous Rating Input	1,510W
Blows Per Minute (BPM)	1,450
Dimensions (L x W x H)	652x121x231mm (25-3/4"x4-3/4"x9-1/8")
Net Weight	15.1kg (33.3lbs)
Power Supply Cord	5.0m (16.4ft)



HM1306/B



Bull Point, Wrench, Side Handle, Oil Supply 100ml



## HM1501 30mm (1-3/16") Electric Breaker

48.1 J Electric Breaker, 30 mm Hex Shank

218



Continuous rating input	1,850W
Impact Energy	EPTA-Procedure 05/2009: 48.0 J
Blows Per Minute (BPM)	1,300
Dimensions (L x W x H)	781 x 130 x 265 mm (30-3/4 x 5-1/8 x 10-3/8")
Net weight	18.4 kg (40.6 lbs.)
Power supply cord	5.0 m (16.4 ft)



Side Handle

## HM1511 30mm (1-3/16") Electric Breaker

48.9 J AVT SOFT NO LOAD Electric Breaker, 30 mm Hex Shank

218



Continuous rating input	1,850W
Impact Energy	EPTA-Procedure 05/2009: 48.0 J
Blows Per Minute (BPM)	1,300
Dimensions (L x W x H)	781 x 130 x 265 mm (30-3/4 x 5-1/8 x 10-3/8")
Net weight	19.2 kg (42.4 lbs.)
Power supply cord	5.0 m (16.4 ft)



Side Handle

## HM1812 28.6mm (1-1/8") Electric Breaker

Highest-in-class demolition power with AVT

218



Continuous Rating Input	2,000W
Blows Per Minute (BPM)	870
Sound Power Level	107 dB(A)
Dimensions (L x W x H)	843x210x608mm (33-1/4"x8-1/4"x24")
Net Weight	31.3kg (69.1lbs)
Power Supply Cord	5.0m (16.4ft)



HM1812/B



Bull point, Hex wrench



PRODUCTS

RECIPRO SAW

JR002GM201(RM2J) / GD201(RD2J) / GZ  
32mm (1-1/4") Cordless Recipro Saw

New

Compatible with a wide range of cutting applications

Li-ion Ah 8.0 5.0 4.0 2.5 2.0



Length of Stroke	32 mm (1-1/4")
Strokes Per Minute (SPM)	0 - 3,000
Capacity	Pipe: 130 mm (5-1/8") Wood: 255 mm (10")
Dimensions (L x W x H)	w/ BL4020 / BL4025: 436 x 97 x 250 mm (17-1/8 x 3-13/16 x 9-7/8")
Net weight	4.6 - 5.2 kg (10.1 - 11.5 lbs.)

40Vmax



XGT BL AVT XPT



Recipro Saw Blades, Charger, Battery, Z: Battery and Charger are sold separately



JR001GM201(RM2J) / GD201(RD2J) / GZ  
32mm (1-1/4") Cordless Recipro Saw

Compact & High Power

Li-ion Ah 8.0 5.0 4.0 2.5 2.0



Length of Stroke	32 mm (1-1/4")
Strokes Per Minute (SPM)	High / Low: 0 - 3,000 / 0 - 2,300
Capacity	Pipe: 130 mm (5-1/8") Wood: 255 mm (10")
Dimensions (L x W x H)	w/ BL4025: 457x88x233 mm (18"x3-1/2"x9-1/8") w/ BL4040: 472x88x239 mm (18-5/8"x3-1/2"x9-3/8")
Net weight	4.2 - 4.5 kg (9.3 - 9.9 lbs.)



40Vmax



XGT BL XPT

Recipro Saw Blades, Charger, Battery, Z: Battery and Charger are sold separately

DJR360PT2 / Z 32mm (1-1/4") Cordless Recipro Saw

Improvement in specifications of cutting speed and stroke length

Li-ion Ah 6.0 5.0 3.0 1.5



Capacity	Pipe: 130mm (5-1/8") Wood: 255mm (10")
Length of stroke	32mm (1-1/4")
Strokes per minute (spm)	High: 0-3,000 Low: 0-2,300
Sound power Level	96 dB(A)
Dimensions (L x W x H)	449x116x243mm (17-3/4"x4-9/16"x9-9/16")
Net weight	4.0kg (8.9lbs)



18V x2

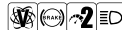

LXT BL XPT

Fast Charger, Batteries, Recipro saw blades, Z: Battery and Charger are sold separately

DJR187RTE / ZK 32mm (1-1/4") Cordless Recipro Saw

Upgraded model of basic model DJR186 high efficiency by Brushless DC Motor

Li-ion Ah 6.0 5.0 3.0 1.5



Length of Stroke	32 mm (1-1/4")
Strokes Per Minute (SPM)	High / Low: 0 - 3,000 / 0 - 2,300
Capacity	Pipe: 130 mm (5-1/8") Wood: 255 mm (10")
Sound Power Level	95 dB(A)
Dimensions (L x W x H)	439x83x231 mm (17-1/4"x3-1/4"x9-1/8")
Net weight	3.4 - 3.8 kg (7.6 - 8.3 lbs)

18V

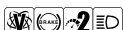

LXT BL XPT



Fast Charger, Batteries, Recipro saw blades, Z: Battery and Charger are sold separately

DJR186RTE / ZK 32mm (1-1/4") Cordless Recipro Saw

Higher cutting speed (Max 2,800 SPM)

441

Li-ion Ah 6.0 5.0 3.0 1.5



Length of Stroke	32 mm (1-1/4")
Strokes Per Minute (SPM)	0 - 2,800
Capacity	Pipe: 130 mm (5-1/8") Wood: 255 mm (10")
Sound Power Level	95 dB(A)
Dimensions (L x W x H)	486x81x223 mm (19-1/8"x3-3/16"x8-3/4")
Net weight	3.5 - 3.8 kg (7.6 - 8.3 lbs)

18V



LXT XPT



Fast Charger, Batteries, Recipro saw blades, Z: Battery and Charger are sold separately

**DJR188RTJ / Z 20mm (13/16") Cordless Recipro Saw**

Two switch levers are available with variable speed control

Li-ion Ah 6.0 5.0 3.0 1.5



Length of Stroke	20 mm (13/16")
Strokes Per Minute (SPM)	0 - 3,000
Capacity	Pipe: 130 mm (5-1/8") Wood: 255 mm (10")
Sound Power Level	94 dB(A)
Dimensions (L x W x H)	with BL1815N / BL1820B: 316x81x203 mm (12-1/2"x3-3/16"x8") with BL1830B / BL1840B / BL1850B / BL1860B: 316x81x220 mm (12-1/2"x3-3/16"x8-5/8")
Net weight	2.6 - 2.9 kg (5.7 - 6.4 lbs)

18V



Recipro Saw Blades, Battery, Fast Charger, Z: Battery and Charger are sold separately

**DJR189RTE / Z 22 mm (7/8") Cordless Recipro Saw**

New

Good combination of compact design and high power

Li-ion Ah 6.0 5.0 3.0 1.5



Capacity	Pipe: 130 mm (5-1/8") Wood: 255 mm (10")
Length of stroke	22 mm (7/8")
Strokes Per Minute (SPM)	0-3,100
Dimensions (L x W x H)	410 x 81 x 182 mm (16-1/8 x 3-3/16 x 7-1/8")
Net weight	2.2 - 2.5 kg (4.9 - 5.5 lbs.)

18V



Recipro saw blades, Battery, Charger, Z: Battery and Charger are sold separately

**DJR183RTE / Z 13mm (1/2") Cordless Recipro Saw**

Two switch levers are available with variable speed control

Li-ion Ah 6.0 5.0 3.0 1.5



Capacity	Pipe: 50 mm (2") Wood: 50 mm (2")
Length of Stroke	13 mm (1/2")
Strokes Per Minute (SPM)	0-3,000
Dimensions (L x W x H)	392x81x209 mm (15-1/2"x3-3/16"x8-1/4")
Net weight	1.5 - 1.7 kg (3.3 - 3.8 lbs)

18V



Fast Charger, Battery Cartridge X2, Recipro Saw Blades, Z: Battery and Charger are sold separately



**JR103DWYE 13mm (1/2") Cordless Recipro Saw**

Slide style battery and improved ergonomic grip

Li-ion Ah 4.0 2.0 1.5



Length of Stroke	13mm (1/2")
Strokes Per Minute (SPM)	0 - 3,300
Capacity	Pipe: 50mm (2") Wood: 50mm (2")
Dimensions (L x W x H)	376x66x186mm (14-3/4"x2-5/8"x7-3/8")
Net Weight	1.3 - 1.5kg (2.9 - 3.3lbs)

12Vmax



Battery, Charger, Recipro Saw Blades, Hex Wrench

**JR3051TK 30mm (1-3/16") Recipro Saw**

1,200 W Recipro Saw

303



Continuous rating input	1,200W
Length of Stroke	30 mm (1-3/16")
Strokes Per Minute (SPM)	0 - 3,000
Capacity	Pipe: 130 mm (5-1/8") Wood: 255 mm (10")
Sound Power Level	99 dB(A)
Dimensions (L x W x H)	447x97x176mm (17-5/8"x3-13/16"x6-15/16")
Net Weight	3.2 - 3.3 kg (7.1 - 7.3 lbs.)
Power supply cord	2.5 m (8.2 ft)



Recipro Saw Blades

**JR3061T 32mm (1-1/4") Recipro Saw**

1,250 W Recipro Saw

303



Continuous rating input	1,250W
Length of Stroke	32 mm (1-1/4")
Strokes Per Minute (SPM)	0 - 3,000
Capacity	Pipe: 130 mm (5-1/8") Wood: 255 mm (10")
Sound Power Level	99 dB(A)
Dimensions (L x W x H)	487x95x177 mm (19-3/16"x3-3/4"x7")
Net Weight	3.8 kg (8.4 lbs.)
Power supply cord	2.5 m (8.2 ft)



Recipro Saw Blades

**JR3070CT 32mm (1-1/4") Recipro Saw**

Extra-low vibration and extra power

303



Continuous rating input	1,510W
Length of Stroke	32 mm (1-1/4")
Strokes Per Minute (SPM)	0 - 2,800
Capacity	Pipe: 130 mm (5-1/8") Wood: 255 mm (10")
Sound Power Level	100 dB(A)
Overall Length	485 mm (19-1/8")
Net Weight	4.6 kg (10.0 lbs)
Power supply cord	2.5 m (8.2 ft)

110V

JR3070CT/B



Recipro Saw Blade Set





PRODUCTS

CUTTING  
(Masonry & Concrete)

DCC500RTE / Z 125mm (5") Cordless Cutter

18V LXT BL AWS ADT Cordless 125 mm (5") Cutter, Dry Type

Li-ion Ah 6.0 | 5.0 | 3.0 | 1.5

Blade Diameter	125 mm (5")
Hole Diameter	20 mm (13/16")
Max Cutting Capacity	90°: 40.0 mm (1-9/16") 45°: 27 mm
No Load Speed (RPM)	8,500
Dimensions (L x W x H)	w/ BL1830B / BL1850B / BL1860B: 283 x 158 x 172 mm
Net weight	2.6 - 3.1 kg (5.7 - 6.8 lbs.)



DCC500RTE / Z  
1

18V LXT BL AWS ADT XPT

Dust Bag, Hex Wrench, Z: Battery and Charger are sold separately

DMC300RTJ / Z Cordless Compact Cut Off

New

18V LXT BL AFT Cordless 76 mm (3") Compact Cut Off

Li-ion Ah 6.0 | 5.0 | 3.0 | 1.5

Blade Diameter	76 mm (3")
No Load Speed (RPM)	20,000
Dimensions (L x W x H)	274 x 105 x 192 mm
Net weight	1.2 - 1.5 kg



18V LXT BL AFT XPT

Dust Collection Cover, Diamond Wheel, Hex Wrench, Battery, Charger, Z: Battery and Charger are sold separately

CC301DSYE / DZ 85mm (85-3/8") Cordless Cutter

Smooth and powerful cutting at the high rotational speed

Li-ion Ah 4.0 | 2.0 | 1.5

Blade Diameter	85 mm (3-3/8")
Max Cutting Capacity	90°: 25.5 mm (1") 45°: 16.5 mm (5/8")
No Load Speed (RPM)	1,600
Tank Capacity	Water : 0.5 L
Vibration Level	Concrete Cutting: 2.5 m/s <sup>2</sup>
Sound Power Level	95 dB(A)
Dimensions (L x W x H)	313x170x125mm (12-3/8"x6-11/16"x4-7/8")
Net Weight	1.9kg (4.1lbs)



12Vmax CXE 2

Fast Charger, Battery Cartridge, Diamond Wheel, Hex Wrench, Water Supply Tank Ass'y, DZ: Battery and Charger are sold separately



SG1251J 125mm (5") Wall Chaser

Compact design for perfect handling

318

Continuous Rating Input Capacity	1,400W
Depth:	0-30mm (0 - 1-3/16")
Width:	6-30 mm (1/4 - 1-3/16")
Blade Diameter	125 mm (5")
No Load Speed (RPM)	10,000
Dimensions (L x W x H)	350x151x178mm (13-3/4"x5-15/16"x7")
Net Weight	4.3kg (9.5lbs)
Power Supply Cord	5.0m (16.4ft)



Diamond Wheel x 2, Hex Wrench, Lock Nut Wrench 1

Diamond Wheel x 2, Hex Wrench, Lock Nut Wrench

4100NH 110mm (4-3/8") Cutter

More powerful cutting in stone, masonry, tile and concrete

303

Continuous Rating Input	1,300W
Blade Diameter	110 mm (4-3/8")
Max Cutting Capacity	90°: 34 mm (1-3/8")
No Load Speed (RPM)	14,500
Dimensions (L x W x H)	234x210x165 mm (9-1/4"x8-1/4"x6-1/2")
Net Weight	2.9 kg (6.5 lbs)
Power Supply Cord	2.5 m (8.2 ft)



Wrench, Socket Wrench (Tool does not come with diamond wheel) 2

Wrench, Socket Wrench (Tool does not come with diamond wheel)

**4100NH3Z 110mm (4-3/8") Cutter**

Powerful 1,300 W motor delivers 13,800 RPM

303

**110V**  
**4100NH3Z/B**

Continuous Rating Input	1,300W
Blade Diameter	110 mm (4-3/8")
Max Cutting Capacity	90°: 32 mm (1-1/4")
No Load Speed (RPM)	13,800
Dimensions (L x W x H)	227x209x166mm (8-15/16"x8-1/4"x6-1/2")
Net Weight	2.8 kg (6.2 lbs)
Power Supply Cord	2.0 m (6.6 ft)

Tool does not come with diamond wheel.  
Items of standard equipment and specifications may vary by country or area



Wrench, Hex Wrench

**4100KB 125mm (5") Dustless Cutter**

125 mm (5") 1,400 W Dustless Cutter, Dry Type

303



Continuous Rating Input	1,400W
Blade Diameter	125 mm (5")
Max Cutting Capacity	40.0 mm (1-9/16")
No Load Speed (RPM)	12,200
Dimensions (L x W x H)	231x220x179 mm (9-1/8"x8-5/8"x7")
Net Weight	3.0 kg (6.6 lbs.)
Power Supply Cord	2.5 m (8.2 ft.)



Diamond Wheel, Dust Bag, Wrench, Hex Wrench

**4107R 180mm (7-1/8") Cutter**

Quick and clean cutting

153



Continuous Rating Input	1,400W
Capacity	Max cutting: 60mm (2-3/8")
Blade Diameter	180 mm (7-1/8")
No Load Speed (RPM)	5,000
Overall Length	370 mm (14-9/16")
Net Weight	6.3kg (14.5lbs)
Power Supply Cord	5.0m (16.4ft)

Tool does not come with diamond wheel



Socket Wrench, Offset Wrench, Water Plug &amp; Tube

**4112HS 305mm (12") Angle Cutter**

305mm (12") diamond wheel provides max. cutting depth of 100mm (4")

204



Continuous Rating Input	2,400W
Capacity	Max cutting: 100mm (4")
Blade Diameter	305 mm (12")
No Load Speed (RPM)	5,000
Overall Length	648 mm (25-1/2")
Net Weight	10.4kg (22.9lbs)
Power Supply Cord	2.5m (8.2ft)

Tool does not come with diamond wheel



Socket Wrench

**4114S 355mm (14") Angle Cutter**

High torque delivered at low motor speed of 3,500 rpm

204

**110V**  
**4114S/B**

Wrench

Continuous Rating Input	2,400W
Capacity	Max cutting: 125mm (5")
Wheel Diameter	355 mm (14")
Hole Diameter	25.4mm (1")
No Load Speed (RPM)	3,500
Dimensions (L x W x H)	673x240x329mm (26-1/2"x9-1/2"x13")
Net Weight	10.8kg (23.9lbs)
Power Supply Cord	2.5m (8.2ft)

Tool does not come with diamond wheel

**PC5000C/B 125mm (5") Concrete Planer**

Most Suitable for Planing Concrete

253



Lock Nut Wrench, Hex Wrench, Dust Bag Assembly, Brush Set

Continuous Rating Input	1,400W
Wheel Diameter	125 mm (5")
Hole Diameter	22.23mm (7/8")
No Load Speed (RPM)	10,000
Dimensions (L x W x H)	437x235x195mm (17-1/8"x9-1/4"x7-5/8")
Net Weight	4.0kg (8.9lbs)
Power Supply Cord	5.0m (16.4ft)

**PC5010C 125mm (5") Concrete Planer**

Superior handling in horizontal and overhead applications

318

**110V**  
**PC5010C/B**

Continuous rating input	1,400W
Wheel Diameter	125 mm (5")
Hole Diameter	22.23 mm (7/8")
No Load Speed (RPM)	4,000 - 9,000
Sound Power Level	96.0 dB(A)
Dimensions (L x W x H)	350x231x179 mm (13-3/4"x9-1/8"x7")
Net weight	2.5 - 3.6 kg (5.5 - 7.9 lbs.)
Power supply cord	4.0 m (13.1 ft)



Offset Diamond Wheel, Lock Nut Wrench

**PW5001C 125mm (5") Stone Polisher**

Powerful 900 W motor with less weight

318



Rubber Pad 100 (M14), Side Grip, Wrench, Head Cover

Continuous Rating Input	900W
Capacity	Pad : 100-125mm (4-5")
No Load Speed (RPM)	2,000-4,000
Overall Length	359 mm (14-1/8")
Net Weight	2.3kg (5.1lbs)
Power Supply Cord	4.0m (13.1ft)



PRODUCTS

METAL CUTTING

CS002GZ 185mm (7-1/4") Cordless Metal Cutter

New

Equipped with a Lever for opening/closing Safety cover

Li-ion Ah 8.0 | 5.0 | 4.0 | 2.5 | 2.0



Wheel DiameterMax	185 mm (7-1/4")
Cutting Capacity	67 mm (2-5/8")
No Load Speed (RPM)	3,500
Sound Power Level	113 dB(A)
Dimensions (LxWxH)	350 x 232 x 270 mm (13-3/4 x 9-1/8 x 10-5/8")
Net weight	4.2 - 5.4 kg (9.3 - 11.9 lbs.)

40Vmax



TCT Saw Blade, Hex wrench, Safety goggles (country-specific), Guide rule (country-specific), Battery, Charger, Z: Battery and Charger are sold separately

DCS553Z 150mm (5-7/8") Cordless Metal Cutter

ADT Cordless Metal Cutter, Electric Brake, Soft Start, Dual LED Lights

Li-ion Ah 6.0 | 5.0 | 3.0 | 1.5



Blade Diameter	150 mm (5-7/8")
Max Cutting Capacity	90°: 57.5 mm (2-1/4")
No Load Speed (RPM)	4,200
Sound Power Level	114 dB(A)
Dimensions (LxWxH)	267x186x250 mm (10-1/2"x7-3/8"x9-7/8")
Net weight	2.8 - 3.1 kg (6.1 - 6.8 lbs.)

18V



TCT Saw Blade, Hex Wrench, Safety Goggles, Guide Rule, Z: Battery and Charger are sold separately

High Speed cutting 20%\* UP



Improvement in ease to attach/ detach Dust box



using a mechanism which allows for attaching/detaching simply by one-hand operation of a plastic lever.

Cutting work amount  
Work volume on a single full battery charge

About **140** cuts

**XPT** eXtreme Protection Technology



DCS552Z 136mm (5-3/8") Cordless Metal Cutter

Self-Dust Collection Box for Cleaner Work Environment

Li-ion Ah 6.0 | 5.0 | 3.0 | 1.5



Blade Diameter	136 mm (5-3/8")
Max Cutting Capacity	90°: 50.5 mm (2")
No Load Speed (RPM)	3,600
Sound Power Level	113 dB(A)
Dimensions (LxWxH)	348x196x203 mm (13-3/4"x7-3/4"x8")
Net weight	2.4 - 2.7 kg (5.3 - 6.0 lbs.)

18V



TCT Saw Blade, Hex Wrench, Safety Goggles, Z: Battery and Charger are sold separately

DSC251ZK 25mm (1") Cordless Steel Rod Cutter

New

Ideal for edge cutting of threaded rods and rebars

Li-ion Ah 6.0 | 5.0 | 3.0 | 1.5



Blade Diameter	110 mm (4-5/16")
Cutting Capacity	Dia.: 10 - 25 mm (3/8" - 1")
No Load Speed (RPM)	2,200
Dimensions (LxWxH)	471 x 137 x 139 mm (18-1/2 x 5-25/64 x 5-15/32")
Net weight	4.0 kg (8.8 lbs.)

18V



Tipped Saw, Dust Bag, Side Grip, Hex Wrench, Battery, Charger, Z: Battery and Charger are sold separately

## 4131 185mm (7-1/4") Metal Cutter

185mm (7-1/4") metal cutter for cutting steel up to 6mm (1/4") in thickness 303



Continuous rating input	1,100W
Blade Diameter	185 mm (7-1/4")
Capacity	Max cutting: 63mm (2-1/2")
No Load Speed (RPM)	3,500
Overall Length	358 mm (14-1/8")
Net Weight	4.8kg (11.3lbs)
Power supply cord	2.5m (8.2ft)



Carbide-Tipped Saw Blade, Hex Wrench, Safety Goggles

## LC1230 305mm (12") Metal Cutting Saw

Fast cuts in light pipe, angle iron, tubing, conduit and channels 203

110V  
LC1230/B

Continuous rating input	1,750W
Blade Diameter	305 mm (12")
Max Cutting Capacity	90°: 115 mm (4-1/2") 90°: 75 x 150 mm (2-15/16" x 5-7/8") 45°: 90 mm (3-1/2") 45°: 85 x 85 mm (3-5/16" x 3-5/16")
No Load Speed (RPM)	1,300
Dimensions (L x W x H)	516x306x603mm (20-1/4"x12"x23-3/4")
Net Weight	19.3kg (42.5lbs)
Power supply cord	2.5m (8.2ft)

Refer to Cutting Capacity table below



Carbide-Tipped Saw Blade (for mild steel), Socket Wrench, Safety Goggles

## PB002GM201(RM2K) / GZ Cordless Portable Band Saw

New

40Vmax XGT BL Cordless Portable Band Saw

Li-ion Ah 8.0 5.0 4.0 2.5 2.0



Capacity	Square: 127 x 127 mm (5 x 5") 0 - 3.2 m/min (0 - 630 ft/min)
Blade Speed	
Blade Size	Length: 1,140 mm (45") Width: 13 mm (1/2") Thickness: 0.5 mm (0.02")
Dimensions (L x W x H)	510 x 218 x 314 mm (20 x 8-5/8 x 12-3/8")
Net weight	6.5 - 7.1 kg (14.3 - 15.7 lbs.)

40Vmax



XGT BL XPT



Band Saw Blade, Hex Wrench, Battery, Charger, Z: Battery and Charger are sold separately

## DPB180Z Cordless Portable Band Saw

Light weight and well balanced tool design 430

Li-ion Ah 6.0 5.0 3.0 1.5



Capacity	Round: 120 mm (4-3/4") Rectangular workpiece without stand : 120x120 mm (4-3/4"x4-3/4")
Blade speed	1.4-2.7 m/s (275-530 ft/min.)
Dimensions (L x W x H)	523x231x313 mm (20-5/8"x9-1/8"x12-3/8")
Net weight	6.8 - 7.1 kg (14.9 - 15.7 lbs)

18V



LXT



Hss Bimetal Band Saw Blade (18 Teeth Per Inch), Hex Wrench, Z: Battery and Charger are sold separately



## DPB183Z Cordless Portable Band Saw

18V LXT BL Cordless Portable Band Saw

Li-ion Ah 6.0 5.0 3.0 1.5



Capacity	Round: 66 mm (2-5/8") Square: 66 x 66 mm (2-5/8" x 2-5/8")
Blade Speed	0 - 3.2 m/s (0 - 630 ft/min.)
Dimensions (L x W x H)	w/ BL1830B / BL1850B / BL1860B: 392x174x242 mm (15-1/2"x6-7/8"x9-1/2")
Net weight	3.6 - 3.9 kg (7.9 - 8.6 lbs.)

18V



LXT BL



Band Saw Blade, Hex Wrench, Hook (country-specific), Grip (country-specific), Battery, Charger, Z: Battery and Charger are sold separately

## DPB184Z Cordless Portable Band Saw

Stable cutting with highly rigid aluminium structure

Li-ion Ah 6.0 5.0 3.0 1.5



Capacity	Round: 51 mm (2") Square: 51 x 51 mm (2" x 2")
Blade Speed	0 - 3.2 m/s (0 - 630 ft/min.)
Dimensions (L x W x H)	w/ BL1830B / BL1850B / BL1860B: 373x162x223 mm (14-3/4"x6-3/8"x8-3/4")
Net weight	3.3 - 3.6 kg (7.3 - 7.9 lbs.)

18V



LXT BL



Band Saw Blade, Hex Wrench, Hook (country-specific), Battery, Charger, Z: Battery and Charger are sold separately

## DPB182Z Cordless Portable Band Saw

18V LXT Li-Ion Cordless Portable Band Saw

Li-ion Ah 6.0 5.0 3.0 1.5



Capacity	Round: 64 mm (2-1/2") Rectangular: 64x64 mm (2-1/2"x2-1/2")
Blade speed	3.2 m/s (630 ft/min.) 477x197x229 mm (18-3/4"x7-3/4"x9")
Dimensions (L x W x H)	
Net weight	3.8 - 4.1 kg (8.3 - 9.0 lbs.)

18V



LXT



Band Saw Blade, Wheel Cover (country-specific), Hook (country-specific), Hex Wrench, Battery, Z: Battery and Charger are sold separately



2107FK Portable Band Saw

Large 120 x 120mm (4-3/4" x 4-3/4") capacity with excellent tool balance 303



Continuous rating input 710W  
Capacity Round: 120 mm (4-3/4")  
Rectangular workpiece Without stand: 120x120mm (4-3/4"x4-3/4")  
Blade speed 1.0 - 1.7 m/s (60m (200 ft) - 105m (350 ft) / min)  
Dimensions (L x W x H) 508x188x256mm (20"x7-3/8"x10-1/8")  
Net Weight 6.3kg (13.9lbs)  
Power supply cord 2.5m (8.2ft)



Carbon Steel Band Saw Blade (18 teeth per inch) 1 pc, Hex Wrench

DSC121ZK Cordless Threaded Rod Cutter

18V LXT BL Brushless Cordless Threaded Rod Cutter

Li-ion Ah 6.0 5.0 3.0 1.5



Capacity Mild Steel: W5/16, M3/8, M1/2, M8, M10, M12  
Stainless Steel: W5/16, M3/8, M1/2, M8, M10, M12  
Work Amount (pcs) W3/8 (Stainless) w/ BL1860B: 560  
Cutting Speed (sec) 3.0  
Dimensions (L x W x H) 212x323x260 mm (8-3/8"x12-3/4"x10-1/4")  
Net weight 6.0 kg (13.2 lbs.)



Cutter Blade, Stand, Oil, Hex Wrench, Battery, Charger, Z: Battery and Charger are sold separately

SC103DZ Cordless Threaded Rod Cutter

12Vmax CXT BL Brushless Cordless Threaded Rod Cutter

Li-ion Ah 4.0 2.0 1.5



Capacity Mild Steel: M10  
Stainless Steel: W3/8  
Min. Cutting Length 20 mm (13/16")  
Max Output 280 W  
Work Amount (pcs) W3/8 (Mild Steel) w/ BL1041B: 700  
W3/8 (Stainless) w/ BL1041B: 550  
M10 (Mild Steel) w/ BL1041B: 550  
Dimensions (L x W x H) w/ BL1041B: 180x107x289 mm (7-1/8"x4-1/4"x11-3/8")  
Net weight 2.7 - 2.8 kg (6.0 - 6.2 lbs.)



Cutter Blade, Hex socket head bolt, Blade Cover, Depth Gauge, Thumb screw, Hex Wrench, Battery, Charger, DZ: Battery and Charger are sold separately

DSC163ZK Cordless Steel Rod Cutter

18V LXT BL Brushless Cordless 16 mm (5/8") Steel Rod Cutter

Li-ion Ah 6.0 5.0 3.0 1.5



Cutting Capacity Dia.: 3 - 16 mm (1/8" - 5/8")  
Cutting Speed (sec) 2.8  
Dimensions (L x W x H) 360x108x276 mm (14-1/8"x4-1/4"x10-7/8")  
Net weight 6.9 kg (15.2 lbs.)



Wrench, Hex Wrench, Oil, Z: Battery and Charger are sold separately

DSC191Z Cordless Steel Rod Cutter

Cutting capacity range of 3 - 20 mm standard rebar 440

Li-ion Ah 6.0 5.0 3.0 1.5



Cutting Capacity Dia.: 3 - 20 mm (1/8" - 3/4")  
Cutting Speed (sec) 6.5  
Sound Power Level 90.1 dB(A)  
Dimensions (L x W x H) 412x121x284 mm (16-1/5"x8-3/8"x11-1/8")  
Net weight 11.1 - 11.2 kg (24.5 - 24.6 lbs.)



Wrench, Hex Wrench, Oil supply, Z: Battery and Charger are sold separately

DPP200ZK Cordless Hole Puncher

18V LXT Li-Ion Cordless Hole Puncher

Li-ion Ah 6.0 5.0 3.0 1.5



Capacity Steel: 20 mm (13/16")  
Stainless Steel: 20 mm (13/16")  
Max Throat Depth 40 mm (1-9/16")  
Dimensions (L x W x H) 417x127x315 mm (16-3/8"x5"x12-3/8")  
Net weight 10.5 kg (23.2 lbs.)



Punch, Dice, Hex Wrench, Spanner, Bar for fastening nuts, Grip, Oil, Z: Battery and Charger are sold separately



Photo: DPP200

Ø20mm / Thickness 8mm  
For mild steel of 65,000 psi tensile strength

The cordless one is now available.



After a punching cycle is completed, hydraulic pressure automatically pulls off the punch from workpiece and returns it to the initial position to enable efficient continuous hole punching.

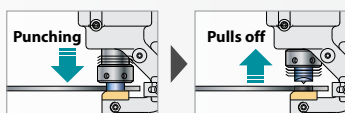

Motor section swivels full 360 degrees.

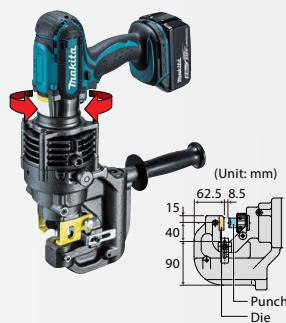

Versatile punch is applicable to a variety of materials: mild steel, stainless steel, channel, aluminum and copper.



Punching capacity

Flat bar	Max: 80mm x t8 (Center punching)
Angle	Min: 40mm x 40mm x t3 Max: 80mm x 80mm x t8
Channel	Min: 75mm x 40mm Max: 100mm x 50mm (Flange punching)

**Abrasive cut-off wheel for portable cut-off**

For all ferrous materials (Steel, cast iron) and other hard metals

Size (mm)	Grit	Pc. per pkg.	Part No.
355 x 2.5 x 25.4	A36P	5	B-49448-5
355 x 2.5 x 25.4	A36P	25	B-49448-25



**Features**

**1. Thinner**



3.0mm



**2. Less burred**



2.5mm

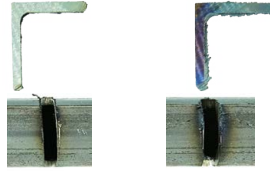

New 2.5mm thickness

Current 3.0mm thickness

**Cutting Capacity**

Form of materials	Miter angle	
	0°	45°
	D: $\varnothing 127\text{mm}$ (2")	D: $\varnothing 127\text{mm}$ (2")
	H x W: 102 x 194mm (4" x 7-5/8") 70 x 233mm (2-3/4" x 9-1/8")	H x W: 115 x 103mm (4-1/2" x 4-1/16")
	H x W: 119 x 119mm (4-11/16" x 4-11/16")	H x W: 106 x 106mm (4-3/16" x 4-3/16")
	S x S: 137 x 137mm, T: 10mm (5-3/8" x 5-3/8", 3/8")	S x S: 100 x 100mm, T: 10mm (4" x 4", 3/8")

D: Diameter W: Width H: Height S: Side T: Thickness

**DLW140Z 355mm (14") Portable Cut-off**

18V X2 (36V) LXT BL 355 mm (14") Toolless Portable Cut-Off

Li-ion Ah 6.0 5.0 3.0 1.5



Wheel Diameter	355 mm (14")
Hole Diameter	25.4 mm (1")
No Load Speed (RPM)	3,800
Max Output	1,300 W
Sound Power Level	115dB
Dimensions (L x W x H)	537x290x640 mm (21-1/8"x11-3/8"x25-1/4")
Net weight	17.2 - 17.8 kg (37.9 - 39.3 lbs.)

18V x2



Abrasive Cut-Off Wheel, Z: Battery and Charger are sold separately

**LW1401 355mm (14") Portable Cut-off**

Powerful 2,200W motor 355mm (14") Portable Cut-off, successor to 2414NB

110V  
LW1401/B



Continuous rating input	2,200W
Wheel Diameter	355 mm (14")
No Load Speed (RPM)	3,800
Capacity at 90°	Round: 127 mm (5") Rectangular: 102x194 mm (4"x7-5/8")
Sound Power Level	110 dB(A)
Dimensions (L x W x H)	500x295x640mm (19-3/4"x11-5/8"x25-1/4")
Net Weight	18.3 kg (40.3 lbs)
Power supply cord	2.5m (8.2ft)

Refer to Cutting Capacity table below



Abrasive cut-off wheel, Socket wrench

**2416S 405mm (16") Portable Cut-off**

405mm (16") blade for more cutting capacity



Continuous rating input	1,430W
Wheel Diameter	405 mm (16")
Hole Diameter	25.4mm (1")
No Load Speed (RPM)	2,300
Dimensions (L x W x H)	610x265x535mm (24"x10-3/8"x21")
Net Weight	19.2kg (42.3lbs)
Power supply cord	2.5m (8.2ft)

Refer to Cutting Capacity table below



Abrasive Cut-Off Wheel, Socket Wrench

**DJS161Z 1.6mm Cordless Straight Shear**

High cutting capacity: cuts up to 1.6 mm thick mild steel sheet

Li-ion Ah 6.0 5.0 3.0 1.5



Capacity	Steel up to 400 N/mm <sup>2</sup> : 1.6 mm Steel up to 600 N/mm <sup>2</sup> : 1.2 mm Aluminum up to 200 N/mm <sup>2</sup> : 2.5 mm
Strokes Per Minute (SPM)	4,300
Dimensions (L x W x H)	362x78x118 mm (14-1/4"x3-1/16"x4-5/8")
Net weight	1.8 - 2.2 kg (4.1 - 4.8 lbs)

18V



Hex Wrench, Thickness Gauge, Z: Battery and Charger are sold separately

**DJS101Z 1.0mm Cordless Metal Shear**

Easy curve cutting

Li-ion Ah 6.0 5.0 3.0 1.5



Capacity	Steel up to 400 N/mm <sup>2</sup> : 1.0 mm Steel up to 600 N/mm <sup>2</sup> : 0.7 mm Aluminum up to 200 N/mm <sup>2</sup> : 2.5 mm
Strokes Per Minute (SPM)	4,300
Dimensions (L x W x H)	364x78x118 mm (14-3/8"x3-1/16"x4-5/8")
Net weight	1.8 - 2.2 kg (4.0 - 4.7 lbs)

18V



Hex Wrench, Z: Battery and Charger are sold separately

**DJS130Z 1.3mm Cordless Metal Shear**

Nibbler without cord expands more operating field

Li-ion Ah 6.0 5.0 3.0 1.5



Capacity	Steel up to 400 N/mm <sup>2</sup> : 1.3 mm Steel up to 600 N/mm <sup>2</sup> : 1.0 mm
No Load Speed (RPM)	2,800
Dimensions (L x W x H)	350x80x193 mm (13-3/4"x3-1/8"x7-5/8")
Net weight	2.3 - 2.6 kg (5.0 - 5.8 lbs)

18V



Hex Wrench, Hook, Z: Battery and Charger are sold separately



**JS1601 1.6mm (16Ga) Straight Metal Shear**

Minimum outside cutting radius of 250 mm (9-7/8")

459



Hex Wrench, Thickness Gauge

Continuous rating input	380W
Capacity	Steel up to 400 N/mm <sup>2</sup> : 1.6mm Steel up to 600 N/mm <sup>2</sup> : 1.2mm Steel up to 800 N/mm <sup>2</sup> : 0.8mm Aluminum up to 200N/mm <sup>2</sup> : 2.5mm
Min. cutting radius	250mm (9-7/8")
Strokes Per Minute (SPM)	4,500
Dimensions (L x W x H)	320x70x78mm (12-5/8"x2-3/4"x3-1/16")
Net Weight	1.4kg (3.1lbs)
Power supply cord	2.5m (8.2ft)

**JS1300 1.3mm Straight Shear**

Low noise level (only 80dB) for quieter operation

419



Hex Wrench

Continuous rating input	570W
Capacity	Steel up to 400 N/mm <sup>2</sup> : 1.3 mm Steel up to 600 N/mm <sup>2</sup> : 1.0 mm Steel up to 800 N/mm <sup>2</sup> : 0.5 mm Aluminum up to 200N/mm <sup>2</sup> : 2.5 mm
Strokes Per Minute (SPM)	0-2,500
Overall Length	302 mm (11-7/8")
Net Weight	1.8 kg (3.9 lbs)
Power supply cord	2.5 m (8.2 ft)

**JS1602 1.6mm (16Ga) Metal Shear**

Cuts 16 Ga. Mild Steel and 18 Ga. Stainless

459



Hex Wrench

Continuous rating input	380W
Capacity	Steel up to 400 N/mm <sup>2</sup> : 1.6mm Steel up to 600 N/mm <sup>2</sup> : 1.2mm Steel up to 800 N/mm <sup>2</sup> : 0.8mm Aluminum up to 200N/mm <sup>2</sup> : 2.5mm
Min. cutting radius	30mm (1-3/16")
Strokes Per Minute (SPM)	4,000
Dimensions (L x W x H)	255x74x146mm (10"x2-15/16"x5-3/4")
Net Weight	1.6kg (3.4lbs)
Power supply cord	2.5m (8.2ft)

**JS3201J 3.2mm (10Ga) Metal Shear**

Robust design with elastomer coated handle provides easy operation

303



Shear Blades Set, Hex Wrench, Thickness Gauge

Continuous rating input	710W
Capacity	Steel up to 400 N/mm <sup>2</sup> : 3.2mm Steel up to 600 N/mm <sup>2</sup> : 2.5mm Steel up to 800 N/mm <sup>2</sup> : 1.5mm Aluminum up to 200N/mm <sup>2</sup> : 4.0mm
Min. cutting radius	50mm (2")
Strokes Per Minute (SPM)	1,600
Dimensions (L x W x H)	213x90x239mm (8-3/8"x3-1/2"x9-3/8")
Net Weight	3.4kg (7.4lbs)
Power supply cord	2.5m (8.2ft)

**DJN161Z 1.6mm (16Ga) Cordless Nibbler**

Nibbler without cord expands more operating field

430

Li-ion Ah 6.0 5.0 3.0 1.5



Hex Wrench, Wrench, Punch, Die, Z; Battery and Charger are sold separately

Capacity	Steel up to 400 N/mm <sup>2</sup> : 1.6 mm Steel up to 600 N/mm <sup>2</sup> : 1.2 mm Aluminum up to 200 N/mm <sup>2</sup> : 2.5 mm
Min. cutting radius	Inside edge : 45 mm (1-3/4") Outside edge : 50 mm (2")
Strokes Per Minute (SPM)	1,900
Dimensions (L x W x H)	313x78x189 mm (12-3/8"x3-1/16"x7-7/16")
Net weight	1.9 - 2.3 kg (4.3 - 5.0 lbs)

**JN1601 1.6mm (16Ga) Nibbler**

2,200 SPM for faster and smooth cutting

411



Hex Wrench, Wrench, Punch, Die

Continuous rating input	550W
Capacity	Steel up to 400 N/mm <sup>2</sup> : 1.6mm Steel up to 600 N/mm <sup>2</sup> : 1.2mm Steel up to 800 N/mm <sup>2</sup> : 0.8mm Aluminum up to 200N/mm <sup>2</sup> : 2.5mm
Min. cutting radius	Outside edge: 50mm (2") Inside edge: 45mm (1-3/4")
Strokes Per Minute (SPM)	2,200
Overall Length	261 mm (10-1/4")
Net Weight	1.6kg (3.6lbs)
Power supply cord	2.0m (6.6ft)

**JN3201J 3.2mm (10Ga) Nibbler**

Robust design with elastomer coated handle provides easy operation

303



Punch, Die, Wrench 50, Hex Wrench, Washer

Continuous rating input	710W
Capacity	Steel up to 400 N/mm <sup>2</sup> : 3.2mm Steel up to 600 N/mm <sup>2</sup> : 2.5mm Steel up to 800 N/mm <sup>2</sup> : 1.0mm Aluminum up to 200N/mm <sup>2</sup> : 3.5mm
Strokes Per Minute (SPM)	1,300
Dimensions (L x W x H)	225x90x254mm (8-7/8"x1-1/2"x10")
Net Weight	3.4kg (7.4lbs)
Power supply cord	2.5m (8.2ft)

**CA5000X 118mm (4-5/8") Aluminum Groove Cutter**

Developed for cutting grooves in aluminum composite materials

303



Cutter blade, Plate, Hex Wrench 5

Continuous Rating Input	1,300W
Blade	Type: Cutter blade / TCT saw blade
Max Cutting Capacity with Cutter blade	with Guide rail: 11 mm (7/16")
Max Cutting Capacity with TCT Saw blade	with Guide rail: 36mm (1-7/16") without Guide rail: 41mm (1-5/8")
No Load Speed (RPM)	2,200-6,400
Dimension (L x W x H)	346x250x250mm (13-5/8"x9-7/8"x9-7/8")
Net Weight	4.7kg (10.4lbs)
Power Supply Cord	2.5m (8.2ft)



### GA038GZ

230mm (9") Cordless Angle Grinder

40Vmax XGT BL Cordless 230 mm (9") Angle Grinder, Large Trigger Switch

Li-ion Ah 8.0 | 5.0 | 4.0 | 2.5 | 2.0



Wheel Diameter	230 mm (9")
Hole Diameter	22.23 mm (7/8")
No Load Speed (RPM)	6,600
Dimensions (L x W x H)	w/ BL4025: 497 x 250 x 156 mm (19-1/2 x 9-7/8 x 6-1/8") w/ BL4040: 509 x 250 x 164 mm (20 x 9-7/8 x 6-1/2")
Net weight	4.6 - 7.4 kg (10.1 - 16.3 lbs.)

### GA037GZ

180mm (7") Cordless Angle Grinder

40Vmax XGT BL Cordless 180mm (7") Angle Grinder, Large Trigger Switch

Li-ion Ah 8.0 | 5.0 | 4.0 | 2.5 | 2.0



Wheel Diameter	180 mm (7")
Hole Diameter	22.23 mm (7/8")
No Load Speed (RPM)	7,800
Dimensions (L x W x H)	w/ BL4025: 497 x 200 x 156 mm (19-1/2 x 7-7/8 x 6-1/8") w/ BL4040: 509 x 200 x 164 mm (20 x 7-7/8 x 6-1/2")
Net weight	4.4 - 5.4 kg (9.7 - 11.9 lbs.)

40Vmax 1  
 Toolless Wheel Cover, Anti-Vibration Grip, Wireless Unit (country-specific), Interchangeable Adapter ADP10 (country-specific), Toolless Lock Nut (country-specific), Battery, Charger, Z: Battery and Charger are sold separately

40Vmax 1  
 Toolless Wheel Cover, Anti-Vibration Grip, Wireless Unit (country-specific), Interchangeable Adapter ADP10 (country-specific), Toolless Lock Nut (country-specific), Battery, Charger, Z: Battery and Charger are sold separately

### GA036GZ / GA035GZ

150mm (6") Cordless Angle Grinder

40Vmax XGT BL AFT, Anti-Restart Function, Electric Brake

Li-ion Ah 8.0 | 5.0 | 4.0 | 2.5 | 2.0



Wheel Diameter	150 mm (6")
Hole Diameter	22.23 mm (7/8")
No Load Speed (RPM)	8,500
Dimensions (L x W x H)	w/ BL4020 / BL4025: 398 x 171 x 156 mm (15-5/8 x 6-3/4 x 6-1/8") w/ BL4040: 410 x 171 x 168 mm (16-1/8 x 6-3/4 x 6-5/8")
Net weight	3.0 - 3.7 kg (6.6 - 8.2 lbs.)

GA035GZ Slide switch  
GA036GZ Paddle switch

GA036GZ / GA035GZ

40Vmax 3  
 Grinding Wheel, Toolless Wheel Cover, Side Grip, Lock Nut Wrench, Battery, Charger, Z: Battery and Charger are sold separately

### GA044GM201(RM2J) / GD201(RD2J) / GZ

125mm (5") Cordless Angle Grinder

40Vmax XGT BL AWS AFT Cordless Angle Grinder, Electric Brake, Paddle Switch, X-LOCK

Li-ion Ah 8.0 | 5.0 | 4.0 | 2.5 | 2.0



Wheel Diameter	125 mm (5")
Hole Diameter	22.23 mm (7/8")
No Load Speed (RPM)	3,000 - 8,500
Dimensions (L x W x H)	w/ BL4040: 433 x 140 x 168 mm (17 x 5-1/2 x 6-5/8")
Net weight	3.0 - 4.8 kg (6.6 - 10.6 lbs.)

40Vmax 1  
 Band Saw Blade, Hex Wrench, Battery, Charger, Z: Battery and Charger are sold separately

### GA029GM201(RM2J) / GD201(RD2J) / GZ

125mm (5") Cordless Angle Grinder

40Vmax XGT BL AWS AFT Cordless Angle Grinder, Electric Brake, Paddle Switch

Li-ion Ah 8.0 | 5.0 | 4.0 | 2.5 | 2.0



Wheel Diameter	125 mm (5")
Hole Diameter	22.23 mm (7/8")
No Load Speed (RPM)	3,000 - 8,500
Dimensions (L x W x H)	w/ BL4025: 413 x 140 x 156 mm (16-1/4 x 5-1/2 x 6-1/8") w/ BL4040: 425 x 140 x 168 mm (16-3/4 x 5-1/2 x 6-5/8")
Net weight	3.0 - 4.5 kg (6.6 - 9.9 lbs.)

GA029GZ 3  
GA029GM201 / GD201 1

40Vmax 3  
 Grinding Wheel, Toolless Wheel Cover, Side Grip, Lock Nut Wrench, Battery, Charger, Z: Battery and Charger are sold separately

### GA013GM201(RM2J) / GD201(RD2J) / GZ

125mm (5") Cordless Angle Grinder

40Vmax XGT BL AFT Cordless Angle Grinder, Electric Brake, Paddle Switch

Li-ion Ah 8.0 | 5.0 | 4.0 | 2.5 | 2.0



Wheel Diameter	125 mm (5")
Hole Diameter	22.23 mm (7/8")
No Load Speed (RPM)	8,500
Dimensions (L x W x H)	w/ BL4025: 398 x 140 x 156 mm (15-5/8 x 5-1/2 x 6-1/8") w/ BL4040: 410 x 140 x 168 mm (16-1/8 x 5-1/2 x 6-5/8")
Net weight	3.0 - 3.6 kg (6.6 - 7.9 lbs.)

GA013GZ 3  
GA013GM201 / GD201 1

40Vmax 3  
 Grinding Wheel, Toolless Wheel Cover, Side Grip, Lock Nut Wrench, Battery, Charger, Z: Battery and Charger are sold separately



**GA023GM201(RM2J) / GD201(RD2J) / GZ**  
125mm (5") Cordless Angle Grinder

40Vmax XGT BL AWS AFT Cordless Angle Grinder, Electric Brake, Slide Switch Lock-On

Li-ion Ah 8.0 5.0 4.0 2.5 2.0



Wheel Diameter	125 mm (5")
Hole Diameter	22.23 mm (7/8")
No Load Speed (RPM)	3,000 - 8,500
Dimensions (L x W x H)	w/BL4025: 413x140x156 mm (16-1/4"x5-1/2"x6-1/8") w/BL4040: 425x140x168 mm (16-3/4"x5-1/2"x6-5/8")
Net weight	3.0 - 4.4 kg (6.6 - 9.7 lbs.)

40Vmax XGT BL AFT AWS XPT

Grinding Wheel, Toolless Wheel Cover, Side Grip, Lock Nut Wrench, Battery, Charger, Z: Battery and Charger are sold separately

**GA005GM201(RM2J) / GD201(RD2J) / GZ**  
125mm (5") Cordless Angle Grinder

40Vmax XGT BL AFT Cordless Angle Grinder, Electric Brake, Slide Switch Lock-On

Li-ion Ah 8.0 5.0 4.0 2.5 2.0



Wheel Diameter	125 mm (5")
Hole Diameter	22.23 mm (7/8")
No Load Speed (RPM)	8,500
Dimensions (L x W x H)	w/BL4025: 398x140x156 mm (15-5/8"x5-1/2"x6-1/8") w/BL4040: 410x140x168 mm (16-1/8"x5-1/2"x6-5/8")
Net weight	2.9 - 3.6 kg (6.4 - 7.9 lbs.)

40Vmax XGT BL AFT AWS XPT

Grinding Wheel, Toolless Wheel Cover / Wheel Cover, Side Handle, Lock Nut Wrench, Battery, Charger, Z: Battery and Charger are sold separately

**GA028GM201(RM2J) / GD201(RD2J) / GZ**  
115mm (4-1/2") Cordless Angle Grinder

40Vmax XGT BL AWS AFT Cordless Angle Grinder, Electric Brake, Paddle Switch

Li-ion Ah 8.0 5.0 4.0 2.5 2.0



Wheel Diameter	115 mm (4-1/2")
Hole Diameter	22.23 mm (7/8")
No Load Speed (RPM)	3,000 - 8,500
Dimensions (L x W x H)	w/BL4025: 413x130x156 mm (16-1/4"x5-1/8"x6-1/8") w/BL4040: 425x130x168 mm (16-3/4"x5-1/8"x6-5/8")
Net weight	3.0 - 3.6 kg (6.6 - 7.9 lbs.)

40Vmax XGT BL AFT AWS XPT

Grinding Wheel, Toolless Wheel Cover, Side Grip, Lock Nut Wrench, Battery, Charger, Z: Battery and Charger are sold separately

**GA012GM201(RM2J) / GD201(RD2J) / GZ**  
115mm (4-1/2") Cordless Angle Grinder

40Vmax XGT BL AFT Cordless Angle Grinder, Electric Brake, Paddle Switch

Li-ion Ah 8.0 5.0 4.0 2.5 2.0



Wheel Diameter	115 mm (4-1/2")
Hole Diameter	22.23 mm (7/8")
No Load Speed (RPM)	8,500
Dimensions (L x W x H)	w/BL4025: 398x130x156 mm (15-5/8"x5-1/8"x6-1/8") w/BL4040: 410x130x168 mm (16-1/8"x5-1/8"x6-5/8")
Net weight	3.0 - 3.6 kg (6.6 - 7.9 lbs.)

40Vmax XGT BL AFT AWS XPT

Grinding Wheel, Toolless Wheel Cover, Side Grip, Lock Nut Wrench, Battery, Charger, Z: Battery and Charger are sold separately

**GA022GM201(RM2J) / GD201(RD2J) / GZ**  
115mm (4-1/2") Cordless Angle Grinder

40Vmax XGT BL AWS AFT Cordless Angle Grinder, Electric Brake, Slide Switch Lock-On

Li-ion Ah 8.0 5.0 4.0 2.5 2.0



Wheel Diameter	115 mm (4-1/2")
Hole Diameter	22.23 mm (7/8")
No Load Speed (RPM)	3,000 - 8,500
Dimensions (L x W x H)	w/BL4025: 413x130x156 mm (16-1/4"x5-1/8"x6-1/8") w/BL4040: 425x130x168 mm (16-3/4"x5-1/8"x6-5/8")
Net weight	3.0 - 3.6 kg (6.6 - 7.9 lbs.)

40Vmax XGT BL AFT AWS XPT

Grinding Wheel, Toolless Wheel Cover, Side Grip, Lock Nut Wrench, Battery, Charger, Z: Battery and Charger are sold separately

**GA004GM201(RM2J) / GD201(RD2J) / GZ**  
115mm (4-1/2") Cordless Angle Grinder

40Vmax XGT BL AFT Cordless Angle Grinder, Electric Brake, Slide Switch Lock-On

Li-ion Ah 8.0 5.0 4.0 2.5 2.0



Wheel Diameter	115 mm (4-1/2")
Hole Diameter	22.23 mm (7/8")
No Load Speed (RPM)	8,500
Dimensions (L x W x H)	w/BL4025: 398x130x156 mm (15-5/8"x5-1/8"x6-1/8") w/BL4040: 410x130x168 mm (16-1/8"x5-1/8"x6-5/8")
Net weight	2.9 - 3.5 kg (6.4 - 7.7 lbs.)

40Vmax XGT BL AFT AWS XPT

Grinding Wheel, Toolless Wheel Cover / Wheel Cover, Side Handle, Lock Nut Wrench, Battery, Charger, Z: Battery and Charger are sold separately

**GA042GM201(RM2J) / GD201(RD2J) / GZ**  
100mm (4") Cordless Angle Grinder **New**

40Vmax XGT BL AWS AFT Cordless Angle Grinder, Electric Brake, Paddle Switch, X-LOCK

Li-ion Ah 8.0 5.0 4.0 2.5 2.0



Wheel Diameter	100 mm (4")
Hole Diameter	16 mm (5/8")
No Load Speed (RPM)	3,000 - 8,500
Dimensions (L x W x H)	w/BL4040: 433 x 117 x 162 mm (17 x 4-5/8 x 6-3/8")
Net weight	3.0 - 4.8 kg (6.6 - 10.6 lbs.)

40Vmax XGT BL AFT AWS X-LOCK XPT

Band Saw Blade, Hex Wrench, Battery, Charger, Z: Battery and Charger are sold separately

**GA027GM201(RM2J) / GD201(RD2J) / GZ**  
100mm (4") Cordless Angle Grinder

40Vmax XGT BL AWS AFT Cordless Angle Grinder, Electric Brake, Paddle Switch

Li-ion Ah 8.0 5.0 4.0 2.5 2.0



Wheel Diameter	100 mm (4")
Hole Diameter	16 mm (5/8")
No Load Speed (RPM)	3,000 - 8,500
Dimensions (L x W x H)	w/BL4025: 413x117x150 mm (16-1/4"x4-5/8"x5-7/8") w/BL4040: 425x117x162 mm (16-3/4"x4-5/8"x6-3/8")
Net weight	2.9 - 3.4 kg (6.4 - 7.5 lbs.)

40Vmax XGT BL AFT AWS XPT

Grinding Wheel, Toolless Wheel Cover, Side Grip, Lock Nut Wrench, Battery, Charger, Z: Battery and Charger are sold separately

**GA011GM201(RM2J) / GD201(RD2J) / GZ**  
100mm (4") Cordless Angle Grinder

40Vmax XGT BL AFT Cordless Angle Grinder, Electric Brake, Paddle Switch

Li-ion Ah 8.0 | 5.0 | 4.0 | 2.5 | 2.0



Wheel Diameter	100 mm (4")
Hole Diameter	16 mm (5/8")
No Load Speed (RPM)	8,500
Dimensions (L x W x H)	w/BL4025: 398x117x150 mm (15-5/8"x4-5/8"x5-7/8") w/BL4040: 410x117x162 mm (16-1/8"x4-5/8"x6-3/8")
Net weight	2.8 - 3.4 kg (6.2 - 7.5 lbs.)

40Vmax XGT BL AFT XPT

Grinding Wheel, Toolless Wheel Cover / Wheel Cover, Side Handle, Lock Nut Wrench, Battery, Charger, Z: Battery and Charger are sold separately

**GA021GM201(RM2J) / GD201(RD2J) / GZ**  
100mm (4") Cordless Angle Grinder

40Vmax XGT BL AWS AFT Cordless Angle Grinder, Electric Brake, Slide Switch Lock-On

Li-ion Ah 8.0 | 5.0 | 4.0 | 2.5 | 2.0



Wheel Diameter	100 mm (4")
Hole Diameter	16 mm (5/8")
No Load Speed (RPM)	3,000 - 8,500
Dimensions (L x W x H)	w/BL4025: 413x117x150 mm (16-1/4"x4-5/8"x5-7/8") w/BL4040: 425x117x162 mm (16-3/4"x4-5/8"x6-3/8")
Net weight	2.8 - 3.4 kg (6.2 - 7.5 lbs.)

40Vmax XGT BL AFT AWS XPT

Grinding Wheel, Toolless Wheel Cover, Side Grip, Lock Nut Wrench, Battery, Charger, Z: Battery and Charger are sold separately



**Auto-start Wireless System**

Switch on the tool, and Vacuum cleaner is activated

It has been impossible, but now Vacuum cleaner can be automatically activated by Cordless tools with our newly developed wireless system.



delivers optimal performance and efficiency even for heavy-duty applications



**Bluetooth® AWS connects to power tool with Bluetooth**

The Bluetooth® word mark and logos are registered trademarks owned by the Bluetooth SIG, Inc. and any use of such marks by Makita is under license. Other trademarks and trade names are those of their respective owners.



**Electric brake**

maximizes productivity and increases safety for operator



**Automatic torque Drive Technology** automatically changes the cutting speed according to load conditions for an optimum operation

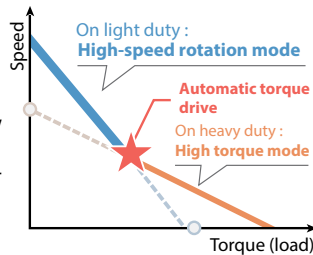

**Active Feedback sensing Technology**

Shuts down the tool to protect the user, if the rotation speed suddenly slows down.

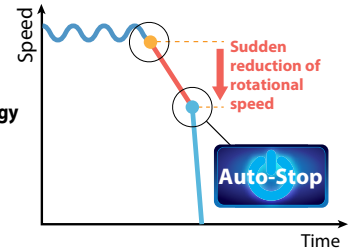

**GA003GM201(RM2J) / GD201(RD2J) / GZ**  
100mm (4") Cordless Angle Grinder

40Vmax XGT BL AFT Cordless Angle Grinder, Electric Brake, Slide Switch Lock-On

Li-ion Ah 8.0 | 5.0 | 4.0 | 2.5 | 2.0



Wheel Diameter	100 mm (4")
Hole Diameter	16 mm (5/8")
No Load Speed (RPM)	8,500
Dimensions (L x W x H)	w/BL4025: 398x117x150 mm (15-5/8"x4-5/8"x5-7/8") w/BL4040: 410x117x162 mm (16-1/8"x4-5/8"x6-3/8")
Net weight	2.8 - 3.3 kg (6.2 - 7.3 lbs.)

40Vmax XGT BL AFT XPT

Grinding Wheel, Toolless Wheel Cover / Wheel Cover, Side Handle, Lock Nut Wrench, Battery, Charger, Z: Battery and Charger are sold separately

**DGA901Z 230mm (9") Cordless Angle Grinder**

High power Cordless Angle Grinder

Li-ion Ah 6.0 | 5.0 | 3.0 | 1.5



Wheel Diameter	230 mm (9")
No Load Speed (RPM)	6,000
Sound Power Level	99 dB(A)
Dimensions (L x W x H)	499x250x158 mm (19-5/8"x9-7/8"x6-1/4")
Net weight	5.2 - 8.0 kg (11.46 - 17.64 lbs)

18V x2 XGT BL ADT AFT AWS XPT

Toolless Wheel Cover / Wheel Cover, Side Grip, Lock Nut Wrench, Z: Battery and Charger are sold separately



**DGA900ZX1** 230mm (9") Cordless Angle Grinder

High power Cordless Angle Grinder

Li-ion Ah 6.0 5.0 3.0 1.5



Wheel Diameter 230 mm (9")  
 No Load Speed (RPM) 6,000  
 Sound Power Level 99 dB(A)  
 Dimensions 499x250x158 mm  
 (L x W x H) (19-5/8"x9-7/8"x6-1/4")  
 Net weight 5.2 - 8.0 kg  
 (11.46 - 17.64 lbs)

18V x2



LXT BL ADT AFT XPT 3

Toolless Wheel Cover / Wheel Cover, Side Grip, Lock Nut Wrench, Z: Battery and Charger are sold separately

**DGA701Z** 180mm (7") Cordless Angle Grinder

High power Cordless Angle Grinder

Li-ion Ah 6.0 5.0 3.0 1.5



Wheel Diameter 180 mm (7")  
 No Load Speed (RPM) 7,800  
 Sound Power Level 99 dB(A)  
 Dimensions 499x200x158 mm  
 (L x W x H) (19-5/8"x7-7/8"x6-1/4")  
 Net weight 5.0 - 6.0 kg  
 (11.0 - 13.2 lbs)

18V x2



LXT BL ADT AFT AWS XPT 3

Toolless Wheel Cover / Wheel Cover, Side Grip, Lock Nut Wrench, Z: Battery and Charger are sold separately

**DGA700ZX1** 180mm (7") Cordless Angle Grinder

High power Cordless Angle Grinder

Li-ion Ah 6.0 5.0 3.0 1.5



Wheel Diameter 180 mm (7")  
 No Load Speed (RPM) 7,800  
 Sound Power Level 99 dB(A)  
 Dimensions 499x200x158 mm  
 (L x W x H) (19-5/8"x7-7/8"x6-1/4")  
 Net weight 5.0 - 6.0 kg  
 (11.0 - 13.2 lbs)

18V x2



LXT BL ADT AFT XPT

Toolless Wheel Cover / Wheel Cover, Side Grip, Lock Nut Wrench, Z: Battery and Charger are sold separately

**DGA519RTJ / Z** 125mm (5") Cordless Angle Grinder

X-LOCK for toolless accessory changes

Li-ion Ah 6.0 5.0 3.0 1.5



Wheel Diameter 125 mm (5")  
 Hole Diameter 22.23 mm (7/8")  
 Max Wheel Thickness 6 mm (1/4")  
 No Load Speed (RPM) 3,000 - 8,500  
 Dimensions 396x140x147 mm  
 (L x W x H) (15-1/2"x5-1/2"x5-3/4")  
 Net weight 2.5 - 3.1 kg (5.5 - 6.8 lbs.)

18V



LXT BL ADT AFT X-LOCK XPT

Grinding Wheel, Wheel Cover, Side Grip, Lock Nut Wrench, Battery, Charger, Z: Battery and Charger are sold separately

**DGA517RTE / Z** 125mm (5") Cordless Angle Grinder

Variable Speed, Anti-Restart Function, Electric Brake, Paddle Switch

Li-ion Ah 6.0 5.0 3.0 1.5



Wheel Diameter 125 mm (5")  
 No Load Speed (RPM) 3,000 - 8,500  
 Dimensions with BL1815N: 368x140x151 mm  
 (L x W x H) (14-1/2"x5-1/2"x6")  
 with BL1830B / BL1850B / BL1860B: 382x140x151 mm  
 (L x W x H) (15"x5-1/2"x6")  
 Net weight 2.4 - 3.1 kg (5.2 - 6.7 lbs.)

18V



LXT BL ADT AFT XPT

Grinding Wheel, Wheel Cover, Side Grip, Lock Nut Wrench, Battery, Fast Charger, Z: Battery and Charger are sold separately

**DGA508RTE / RFE / Z** 125mm (5") Cordless Angle Grinder

Excellent performance and User protection

Li-ion Ah 6.0 5.0 3.0 1.5



Wheel Diameter 125 mm (5")  
 No Load Speed (RPM) 8,500  
 Dimensions 362x140x151 mm  
 (L x W x H) (14-1/4"x5-1/2"x5-15/16")  
 Net weight 2.35 - 3.83 kg  
 (5.18 - 8.45 lbs)

18V



LXT BL ADT AFT XPT

Fast charger, Battery cartridge, Depressed center grinding wheel, Lock nut wrench, Side grip, Z: Battery and Charger are sold separately



**Variable speed control dial (3,000 - 8,500 RPM)**

Matches the speed to your application.



	No load speed (RPM)	Cutting / Rough grinding	Grinding / Finish grinding	Rust removal / Paint removal	Stainless steel polishing
1	3,000				✓
2	4,500			✓	✓
3	6,000		✓	✓	✓
4	7,500		✓		
5	8,500	✓			



**DGA513RTE / Z 125mm (5") Cordless Angle Grinder**

Variable Speed, Anti-Restart Function, Electric Brake, Slide Switch Lock-On

Li-ion Ah 6.0 5.0 3.0 1.5



DGA513RTE 2  
DGA513Z 3

Wheel Diameter	125 mm (5")
No Load Speed (RPM)	3,000 - 8,500
Dimensions (L x W x H)	with BL1815N: 368x140x151 mm (14-1/2"x5-1/2"x5-15/16") with BL1830B / BL1850B / BL1860B: 382x140x151 mm (15"x5-1/2"x5-15/16")
Net weight	2.4 - 3.0 kg (5.2 - 6.7 lbs.)

18V LXT BL ADT AFT XPT

Grinding Wheel, Wheel Cover, Side Grip, Lock Nut Wrench, Battery, Fast Charger, Z: Battery and Charger are sold separately

**DGA506RTE / RFE / Z 125mm (5") Cordless Angle Grinder**

Excellent performance and user protection

Li-ion Ah 6.0 5.0 3.0 1.5



DGA506RTE / RFE 2  
DGA506Z 3

Wheel Diameter	125 mm (5")
No Load Speed (RPM)	8,500
Dimensions (L x W x H)	362x140x151 mm (14-1/4"x5-1/2"x5-15/16")
Net weight	2.35 - 3.83 kg (5.18 - 8.45 lbs)

18V LXT BL ADT AFT XPT

Fast charger, Battery cartridge, Depressed center grinding wheel, Lock nut wrench, Side grip, Z: Battery and Charger are sold separately

**DGA419RTJ / Z 100mm (4") Cordless Angle Grinder**

X-LOCK for toolless accessory changes

Li-ion Ah 6.0 5.0 3.0 1.5



DGA419RTJ 1  
DGA419Z 3

Wheel Diameter	100 mm (4")
Hole Diameter	22.23 mm (7/8")
Max Wheel Thickness	6 mm (1/4")
No Load Speed (RPM)	3,000 - 8,500
Dimensions (L x W x H)	396x117x147mm (15-1/2"x4-5/8"x5-3/4")
Net weight	2.4 - 3.0 kg (5.3 - 6.6 lbs.)

18V LXT BL ADT AFT X-LOCK XPT

Grinding Wheel, Wheel Cover, Side Grip, Lock Nut Wrench, Battery, Charger, Z: Battery and Charger are sold separately

**DGA417RTE / Z 100mm (4") Cordless Angle Grinder**

Variable Speed, Anti-Restart Function, Electric Brake, Paddle Switch

Li-ion Ah 6.0 5.0 3.0 1.5



2

Wheel Diameter	100 mm (4")
No Load Speed (RPM)	3,000 - 8,500
Dimensions (L x W x H)	with BL1815N: 368x117x146 mm (14-1/2"x4-5/8"x5-3/4") with BL1830B / BL1850B / BL1860B: 382x117x146 mm (15"x4-5/8"x5-3/4")
Net weight	2.2 - 2.9 kg (4.9 - 6.3 lbs.)

18V LXT BL ADT AFT XPT

Grinding Wheel, Wheel Cover, Side Grip, Lock Nut Wrench, Battery, Fast Charger, Z: Battery and Charger are sold separately



**Just One Click**

**X-LOCK** Quick and Effortless Wheel Change System

Just Snap-in

Just Pull It



**DGA408RTJ1 / Z 100mm (4") Cordless Angle Grinder**

Excellent performance and User protection

Li-ion Ah 6.0 5.0 3.0 1.5



DGA408RTJ1 1  
DGA408Z 3

Wheel Diameter	100 mm (4")
No Load Speed (RPM)	8,500
Dimensions (L x W x H)	362x117x146 mm (14-1/4"x4-5/8"x5-3/4")
Net weight	2.18 - 2.80 kg (4.81 - 6.17 lbs)

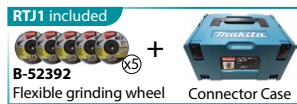

18V LXT BL ADT AFT XPT

Fast charger, Battery cartridge, Depressed center grinding wheel, Lock nut wrench, Side grip, Z: Battery and Charger are sold separately

**DGA413RTE / Z 100mm (4") Cordless Angle Grinder**

Variable Speed, Anti-Restart Function, Electric Brake, Slide Switch Lock-On

Li-ion Ah 6.0 5.0 3.0 1.5



DGA413RTE 2  
DGA413Z 3

Wheel Diameter	100 mm (4")
No Load Speed (RPM)	3,000 - 8,500
Dimensions (L x W x H)	with BL1815N: 368x117x147 mm (14-1/2"x4-5/8"x5-3/4") with BL1830B / BL1850B / BL1860B: 382x117x147 mm (15"x4-5/8"x5-3/4")
Net weight	2.2 - 2.8 kg (4.9 - 6.2 lbs.)

18V LXT BL ADT AFT XPT

Grinding Wheel, Wheel Cover, Side Grip, Lock Nut Wrench, Battery, Fast Charger, Z: Battery and Charger are sold separately



**DGA406RTE / RFE / Z**  
100mm (4") Cordless Angle Grinder

Excellent performance and User protection

Li-ion Ah 6.0 5.0 3.0 1.5



Wheel Diameter	100 mm (4")
No Load Speed (RPM)	8,500
Dimensions (L x W x H)	362x117x146 mm (14-1/4"x4-5/8"x5-3/4")
Net weight	2.18 - 2.77 kg (4.81 - 6.12 lbs)



18V LXT BL ADT AFT XPT

Fast charger, Battery cartridge, Depressed center grinding wheel, Lock nut wrench, Side grip, Z: Battery and Charger are sold separately

**9500NB** 100mm (4") Angle Grinder

Compact and lightweight body works well in close quarters

411



Continuous Rating Input	570W
Wheel Diameter	100 mm (4")
No Load Speed (RPM)	12,000
Overall Length	253 mm (10")
Net Weight	1.9kg (3.5 - 4.3lbs)
Power Supply Cord	2.5m (8.2ft)



Depressed Center Wheel, Wheel Cover, Lock Nut Wrench

**9553HNG** 100mm (4") Angle Grinder

Reliable machined gears provide twice or more longer service life

325



Continuous Rating Input	710W
Wheel Diameter	100 mm (4")
No Load Speed (RPM)	11,000
Dimensions (L x W x H)	258 x 118 x 97 mm (10-1/8" x 4-5/8" x 3-13/16")
Net Weight	1.5 - 1.8 kg (3.2 - 4.1 lbs.)
Power Supply Cord	2.5 m (8.2 ft.)



Depressed Center Wheel, Side grip, Wheel Cover, Lock nut wrench

**GA4031** 100mm (4") Angle Grinder

Powerful 720 W motor with excellent heat resistance

459



Continuous Rating Input	720W
Wheel Diameter	100 mm (4")
No Load Speed (RPM)	11,000
Dimensions (L x W x H)	259x118x104mm (10-1/4"x4-5/8"x4-1/8")
Net Weight	1.7 - 2.0 kg (3.77 - 4.41 lbs)
Power Supply Cord	2.5m (8.2ft)



Depressed Center Wheel, Lock Nut Wrench

**GA4030** 100mm (4") Angle Grinder

Small diameter barrel grip for added comfort

459



Continuous Rating Input	720W
Wheel Diameter	100 mm (4")
No Load Speed (RPM)	11,000
Vibration Level	Surface Grinding: 7.0 m/s <sup>2</sup> Disc Sanding: 2.5 m/s <sup>2</sup> or less
Sound Power Level	96 dB(A)
Dimensions (L x W x H)	266x117x95mm (10-1/2"x4-5/8"x3-3/4")
Net Weight	1.73 - 2.02kg (3.81 - 4.45lbs)
Power Supply Cord	2.5m (8.2ft)



Depressed Center Wheel, Lock Nut Wrench, Side Grip

**9556HNG** 100mm (4") Angle Grinder

Ergonomic paddle switch featured

325



Continuous Rating Input	840W
Wheel Diameter	100 mm (4")
No Load Speed (RPM)	11,000
Dimensions (L x W x H)	271x118x97 mm (10-5/8"x4-5/8"x3-13/16")
Net Weight	1.6 - 2.0 kg (3.6 - 4.4 lbs.)
Power Supply Cord	2.5 m (8.2 ft.)



Depressed Center Wheel, Side Grip, Wheel Cover, Lock Nut Wrench

**GA4040** 100mm (4") Angle Grinder

"Super Joint System II" developed for effective vibration absorption

325



Continuous Rating Input	1,100W
Wheel Diameter	100 mm (4")
No Load Speed (RPM)	11,000
Sound Power Level	97 dB(A)
Dimensions (L x W x H)	303x117x111 mm (11-7/8"x4-5/8"x4-3/8")
Net Weight	2.2 - 2.5 kg (4.9 - 5.6 lbs)
Power Supply Cord	2.5 m (8.2 ft)



Depressed Center Wheel, Lock Nut Wrench, Side Grip

**GA4050R** 100mm (4") Angle Grinder

100 mm (4") 1,300 W Angle Grinder, Anti-Restart Function, Paddle Switch

260



Continuous Rating Input	1,300W
Wheel Diameter	100 mm (4")
No Load Speed (RPM)	11,000
Vibration Level	Surface Grinding w/ Normal Side Grip: 6.5 m/s <sup>2</sup>
Sound Power Level	102 dB(A)
Dimensions (L x W x H)	325 x 117 x 100 mm (12-3/4" x 4-5/8" x 4-5/16")
Net Weight	2.3 - 2.6 kg (5.1 - 5.7 lbs.)
Power Supply Cord	2.5 m (8.2 ft)



Depressed Center Wheel, Side Grip, Wheel Cover, Lock Nut Wrench



# SJST II

## SUPER JOINT SYSTEM

### To suppress vibration to operator

without SJS



SJST II  
SUPER JOINT SYSTEM

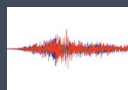

### Structure of Super Joint System II

Leaf spring absorbs vibration and relieves shock during operation



Absorption mechanism of vibration

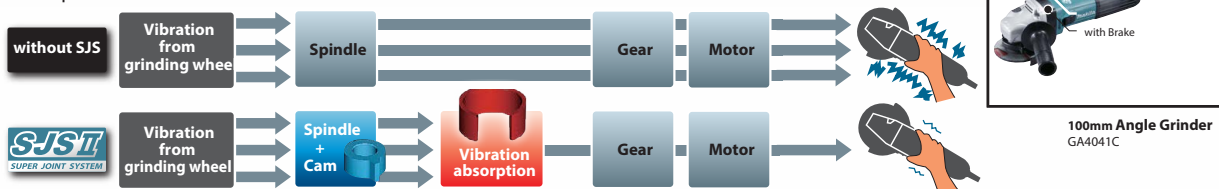

### GA4040C 100mm (4") Angle Grinder

"Super Joint System II" developed for effective vibration absorption

318



Continuous Rating Input	1,400W
Wheel Diameter	100 mm (4")
No Load Speed (RPM)	2,800-11,000
Sound Power Level	97 dB(A)
Dimensions (L x W x H)	303x117x111mm (11-7/8"x4-5/8"x4-3/8")
Net Weight	2.3 - 2.6kg (5.1 - 5.7lbs)
Power Supply Cord	2.5m (8.2ft)



Depressed Center Wheel, Lock Nut Wrench, Side Grip

### GA4041C 100mm (4") Angle Grinder

Anti-Restart Function, Soft start, Mechanical Brake, Slide Switch

318



Continuous Rating Input	1,400W
Wheel Diameter	100 mm (4")
No Load Speed (RPM)	2,800-11,000
Dimensions (L x W x H)	325x117x117mm (12-3/4"x4-5/8"x4-5/8")
Net Weight	2.5 - 2.8kg (5.6 - 6.2 lbs)
Power Supply Cord	2.5m (8.2ft)



Depressed Center Wheel, Lock Nut Wrench, Side Grip

### GA4034 100mm (4") Angle Grinder

Easy to operate paddle switch by the hand gripping motor housing

459



Continuous Rating Input	720W
Wheel Diameter	100 mm (4")
No Load Speed (RPM)	11,000
Vibration Level	Surface Grinding: 7.5 m/s <sup>2</sup> Disc Sanding: 2.5 m/s <sup>2</sup> or less
Sound Power Level	97 dB(A)
Dimensions (L x W x H)	265x118x95mm (10-3/8"x4-5/8"x3-3/4")
Net Weight	1.77 - 2.06kg (3.9 - 4.54 lbs)
Power Supply Cord	2.5m (8.2ft)



Depressed Center Wheel, Lock Nut Wrench, Side Grip

### 9556PBG 100mm (4") Angle Grinder

Ergonomic paddle switch featured

325



Continuous Rating Input	840W
Wheel Diameter	100 mm (4")
No Load Speed (RPM)	11,000
Sound Power Level	96 dB(A)
Dimensions (L x W x H)	273x118x97mm (10-3/4"x4-5/8"x3-13/16")
Net Weight	1.6 - 2.0 kg (3.6 - 4.5 lbs)
Power Supply Cord	2.5 m (8.2 ft.)



Depressed Center Wheel, Lock Nut Wrench, Side Grip



**GA4530 115mm (4-1/2") Angle Grinder**

Small diameter barrel grip for added comfort

459



Continuous Rating Input	720W
Wheel Diameter	115 mm (4-1/2")
No Load Speed (RPM)	11,000
Sound Power Level	96 dB(A)
Dimensions (L x W x H)	266x128x103mm (10-1/2"x5"x4-1/16")
Net Weight	1.89 - 2.23kg (4.17 - 4.91lbs)
Power Supply Cord	2.5m (8.2ft)



Depressed Center Wheel, Lock Nut Wrench, Side Grip

**9557HNG 115mm (4-1/2") Angle Grinder**

840 W Angle Grinder, Anti-Restart Function, Soft Start, Slide Switch

325



Continuous Rating Input	840W
Wheel Diameter	115 mm (4-1/2")
No Load Speed (RPM)	11,000
Sound Power Level	97 dB(A)
Dimensions (L x W x H)	271x129x106 mm (10-5/8"x5-1/8"x4-3/16")
Net Weight	1.7 - 2.2 kg (3.8 - 5.3 lbs.)
Power Supply Cord	2.5 m (8.2 ft.)



Depressed Center Wheel, Side Grip, Wheel Cover, Lock Nut Wrench

**GA4550R 115mm (4-1/2") Angle Grinder**

115 mm (4-1/2") 1,300W Angle Grinder, Anti-Restart Function, Paddle Switch

260



Continuous Rating Input	1,300W
Wheel Diameter	115 mm (4-1/2")
No Load Speed (RPM)	11,000
Vibration Level	Surface Grinding w/ Normal Side Grip: 7.0 m/s <sup>2</sup>
Sound Power Level	102 dB(A)
Dimensions (L x W x H)	325 x 130 x 117 mm (12-3/4 x 5-1/8 x 4-5/8")
Net Weight	2.4 - 2.8 kg (5.3 - 6.2 lbs.)
Power Supply Cord	2.5 m (8.2 ft)



Depressed Center Wheel, Side Grip, Wheel Cover, Lock Nut Wrench

**GA5030 125mm (5") Angle Grinder**

Small diameter barrel grip for added comfort

459



Continuous Rating Input	720W
Wheel Diameter	125 mm (5")
No Load Speed (RPM)	11,000
Sound Power Level	96 dB(A)
Dimensions (L x W x H)	266x138x103mm (10-1/2"x5-7/16"x4-1/16")
Net Weight	1.92 - 3.07kg (4.23 - 6.77lbs)
Power Supply Cord	2.5m (8.2ft)



Depressed Center Wheel, Lock Nut Wrench, Side Grip

**GA5034 125mm (5") Angle Grinder**

Easy to operate paddle switch by the hand gripping motor housing

459



Continuous Rating Input	720W
Wheel Diameter	125 mm (5")
No Load Speed (RPM)	11,000
Sound Power Level	97 dB(A)
Dimensions (L x W x H)	265x139x103mm (10-3/8"x5-1/2"x4-1/16")
Net Weight	2 - 3.15kg (4.41 - 6.94lbs)
Power Supply Cord	2.5m (8.2ft)



Depressed Center Wheel, Lock Nut Wrench, Side Grip

**GA5040CZ 125mm (5") Angle Grinder**

SJS II Variable Speed Angle Grinder, Anti-Restart Function, Soft Start, Slide Switch

318



Continuous Rating Input	1,400W
Wheel Diameter	125 mm (5")
No Load Speed (RPM)	2,800-11,000
Sound Power Level	97 dB(A)
Dimensions (L x W x H)	303x140x116 mm (11-7/8"x5-1/2"x4-9/16")
Net Weight	2.5 - 3.6 kg (5.6 - 8.0 lbs.)
Power Supply Cord	2.5 m (8.2 ft)

Tool does not come with depressed center wheel



Side Grip, Wheel Cover, Lock Nut Wrench

**9558HNG 125mm (5") Angle Grinder**

840 W Angle Grinder, Slide Switch

325



Continuous Rating Input	840W
Wheel Diameter	125 mm (5")
No Load Speed (RPM)	11,000
Sound Power Level	97 dB(A)
Dimensions (L x W x H)	273x139x106 mm (10-3/4"x5-1/2"x4-3/16")
Net Weight	1.7 - 3 kg (3.8 - 6.6 lbs.)
Power Supply Cord	2.5 m (8.2 ft)



Depressed Center Wheel, Side Grip, Wheel Cover, Lock Nut Wrench

**GA5010 125mm (5") Angle Grinder**

Refined design for reduced operator fatigue

303



Continuous Rating Input	1,050W
Wheel Diameter	125 mm (5")
No Load Speed (RPM)	12,000
Sound Power Level	100 dB(A)
Dimensions (L x W x H)	356x139x112mm (14"x5-1/2"x4-3/8")
Net Weight	2.6 - 3.8kg (5.8 - 8.4lbs)
Power Supply Cord	2.5m (8.2ft)



Depressed Center Wheel, Lock Nut Wrench, Side Grip

## GA5050R 125mm (5") Angle Grinder

125 mm (5") 1,300 W Angle Grinder, Anti-Restart Function, Paddle Switch 260 

Continuous Rating Input	1,300W
Wheel Diameter	125 mm (5")
No Load Speed (RPM)	11,000
Vibration Level	Surface Grinding w/ Normal Side Grip: 7.5 m/s <sup>2</sup>
Sound Power Level	102 dB(A)
Dimensions (L x W x H)	325 x 140 x 117 mm (12-3/4 x 5-1/2 x 4-5/8")
Net Weight	2.5 - 2.8 kg (5.5 - 6.2 lbs.)
Power Supply Cord	2.5 m (8.2 ft)



Depressed Center Wheel, Side Grip, Wheel Cover, Lock Nut Wrench

## GA5080R 125mm (5") Angle Grinder

125 mm (5") 1,400 W Angle Grinder, Soft Start, Slide Switch, X-LOCK 318 

Continuous rating input	1,400W
Wheel Diameter	125 mm (5")
Hole Diameter	22.3 mm (7/8")
Max cutting depth	31 mm (1-1/4")
No Load Speed (RPM)	12,000
Dimensions (L x W x H)	309 x 141 x 113 mm (12-1/8 x 5-9/16 x 4-7/16")
Net weight	2.5 - 3.6 kg (5.5 - 7.9 lbs.)
Power supply cord	2.5 m (8.2 ft)



Depressed Center Wheel, Side Grip, Wheel Cover



## GA6010 150mm (6") Angle Grinder

Externally accessible brushes for greater serviceability 303 110V 

## GA6010X3/B



Continuous Rating Input	1,050W
Wheel Diameter	150 mm (6")
No Load Speed (RPM)	10,000
Sound Power Level	101 dB(A)
Dimensions (L x W x H)	356x169x112mm (14"x6-5/8"x4-3/8")
Net Weight	2.7 - 3.1 kg (5.9 - 6.9 lbs)
Power Supply Cord	2.5m (8.2ft)



Depressed Center Wheel, Lock Nut Wrench, Side Grip

## GA6020C 150mm (6") Angle Grinder

Trigger Switch with Lock-On Button 253 

Continuous Rating Input	1,450W
Wheel Diameter	150 mm (6")
No Load Speed (RPM)	9,000
Sound Power Level	102 dB(A)
Dimensions (L x W x H)	390 x 169 x 120 mm (15-3/8 x 6-5/8 x 4-3/4")
Net Weight	3 - 3.5 kg (6.7 - 7.6 lbs.)
Power Supply Cord	2.5m (8.2ft)



Depressed Center Wheel, Side grip, Wheel Cover, Lock nut wrench

## GA7020 180mm (7") Angle Grinder

Outstanding durability 204 

Continuous Rating Input	2,200W
Wheel Diameter	180 mm (7")
No Load Speed (RPM)	8,500
Sound Power Level	100 dB(A)
Dimensions (L x W x H)	473x200x140mm (18-5/8"x7-7/8"x5-1/2")
Net Weight	5.5 - 6.06kg (12.26 - 13.36 lbs)
Power Supply Cord	2.5m (8.2ft)

Tool does not come with depressed center wheel



Lock Nut Wrench, Side Grip

## GA7060 180mm (7") Angle Grinder

Developed for heavy duty applications such as foundry grinding 218 110V 

## GA7060R/B

Continuous Rating Input	2,200W
Wheel Diameter	180 mm (7")
No Load Speed (RPM)	8,500
Sound Power Level	102 dB(A)
Dimensions (L x W x H)	450x200x144mm (17-3/4"x7-7/8"x5-5/8")
Net Weight	5.38 - 5.89 kg (11.9 - 13 lbs)
Power Supply Cord	2.5 m (8.2 ft)

Tool does not come with depressed center wheel



Side grip, Lock nut wrench

## GA7061R 180mm (7") Angle Grinder

SJS II Angle Grinder, Anti-Restart Function, Soft Start, Large Trigger Switch 218 

Continuous Rating Input	2,200W
Wheel Diameter	180 mm (7")
No Load Speed (RPM)	8,500
Sound Power Level	102 dB(A)
Dimensions (L x W x H)	450x200x145mm (17-3/4"x7-7/8"x5-3/4")
Net Weight	5.57 - 6.08kg (12.3 - 13.4 lbs)
Power Supply Cord	2.5 m (8.2 ft)

Tool does not come with depressed center wheel



Side grip, Lock nut wrench



**GA7081 180mm (7") Angle Grinder**

**New**

2,700 W Angle Grinder, Large Trigger Switch



Continuous rating input	2,700W
Wheel Diameter	180 mm (7")
No Load Speed (RPM)	8,500
Dimensions (L x W x H)	499 x 200 x 144 mm (19-5/8 x 7-7/8 x 5-5/8")
Net weight	6.1 - 6.6 kg
Power supply cord	2.5 m (8.2 ft)

without Rotatable Handle



Side Grip, Wheel Cover, Lock Nut Wrench

**GA7070X1 180mm (7") Angle Grinder**

**New**

2,800 W AFT Angle Grinder, Anti-Restart Function, Soft Start, Electric Brake, Large Trigger Switch



**GA7070X1/B**



Continuous rating input	2,800W
Wheel Diameter	180 mm (7")
Hole Diameter	22.23 mm (7/8")
No Load Speed (RPM)	8,500
Dimensions (L x W x H)	506 x 200 x 146 mm (20 x 7-7/8 x 5-3/4")
Net weight	6.1 - 6.6 kg (13.5 - 14.6 lbs.)
Power supply cord	2.5 m (8.2 ft)



Side Grip, Wheel Cover, Lock Nut Wrench

**GA9060 230mm (9") Angle Grinder**

Developed for heavy duty applications such as foundry grinding

**218**



Continuous Rating Input	2,200W
Wheel Diameter	230 mm (9")
No Load Speed (RPM)	6,600
Sound Power Level	102 dB(A)
Dimensions (L x W x H)	450x250x144mm (17-3/4"x9-7/8"x5-5/8")
Net Weight	5.50 - 7.86kg (12.1 - 17.3 lbs)
Power Supply Cord	2.5 m (8.2 ft)

Tool does not come with depressed center wheel



Side grip, Lock nut wrench

**GA9020 230mm (9") Angle Grinder**

Outstanding durability

**204**



Continuous Rating Input	2,200W
Wheel Diameter	230 mm (9")
No Load Speed (RPM)	6,000
Sound Power Level	100 dB(A)
Dimensions (L x W x H)	473x249x140mm (18-5/8"x9-3/4"x5-1/2")
Net Weight	5.76 - 8.05kg (12.7 - 17.8 lbs)
Power Supply Cord	2.5m (8.2ft)

Tool does not come with depressed center wheel



Lock Nut Wrench, Side Grip

**GA9081 230mm (9") Angle Grinder**

**New**

2,700 W Angle Grinder, Large Trigger Switch



Continuous rating input	2,700W
Wheel Diameter	230 mm (9")
No Load Speed (RPM)	6,600
Dimensions (L x W x H)	499 x 250 x 144 mm (19-5/8 x 9-7/8 x 5-5/8")
Net weight	6.3 - 8.4 kg
Power supply cord	2.5 m (8.2 ft)

without Rotatable Handle



Side Grip, Wheel Cover, Lock Nut Wrench

**GA9070X1 230mm (9") Angle Grinder**

**New**

2,800 W AFT Angle Grinder, Anti-Restart Function, Soft Start, Electric Brake, Large Trigger Switch



Continuous rating input	2,800W
Wheel Diameter	230 mm (9")
Hole Diameter	22.23 mm (7/8")
No Load Speed (RPM)	6,600
Dimensions (L x W x H)	506 x 250 x 146 mm (20 x 9-7/8 x 5-3/4")
Net weight	6.3-8.5 kg (13.9 - 18.7 lbs.)
Power supply cord	2.5 m (8.2 ft)



Side Grip, Wheel Cover, Lock Nut Wrench

**DGD800Z 8mm (1/4") Cordless Die Grinder**

Now free from cord for easy job site portability

**430**

Li-ion Ah 6.0 | 5.0 | 3.0 | 1.5



Capacity	Collet: 3 mm - 8 mm
Wheel Diameter	38 mm (1-1/2")
No Load Speed (RPM)	26,000
Dimensions (L x W x H)	402x82x118 mm (15-3/4"x3-1/4"x4-5/8")
Net weight	1.7 - 2.2 kg (3.8 - 4.9 lbs)

18V



Collet Cone, Wrench, Z: Battery and Charger are sold separately.



**GD0600** 6mm (1/4") Die Grinder

Small-circumference housing for easy handling

325

**110V**  
**GD0600/B**



Continuous Rating Input	400W
Capacity	Collet: 3,6mm or 1/8", 1/4"
Wheel Diameter	38 mm (1-1/2")
No Load Speed (RPM)	25,000
Dimensions (L x W x H)	358x82x82mm (14-1/8"x3-1/4"x3-1/4")
Net Weight	1.7 - 1.87kg (3.77 - 4.12 lbs)
Power Supply Cord	2.5m (8.2ft)

**5**  
Wrench (2pcs)

**GD0601** 6mm (1/4") Die Grinder

Small-circumference housing for easy handling

325

**110V**  
**GD0601/B**



Continuous Rating Input	400W
Capacity	Collet: 3,6mm or 1/8", 1/4"
Wheel Diameter	38 mm (1-1/2")
No Load Speed (RPM)	25,000
Dimensions (L x W x H)	359x82x82mm (14-1/8"x3-1/4"x3-1/4")
Net Weight	1.68 - 1.84kg (3.7 - 4.06 lbs)
Power Supply Cord	2.5m (8.2ft)

**5**  
Wrench (2pcs)

**GD0602** 6mm (1/4") Die Grinder

Compact body with short nose

325

**110V**  
**GD0602/B**



Continuous Rating Input	400W
Capacity	Collet: 3,6,8mm or 1/8", 1/4"
Wheel Diameter	38 mm (1-1/2")
No Load Speed (RPM)	25,000
Dimensions (L x W x H)	264x82x82mm (10-3/8"x3-1/4"x3-1/4")
Net Weight	1.4kg (3.2lbs)
Power Supply Cord	2.5m (8.2ft)

**5**  
Wrench (2pcs)

**GD0603** 6mm (1/4") Die Grinder

Easy handling, Compact Die grinder with new aesthetic design

64

**110V**  
**GD0603/B**



Continuous Rating Input	240W
Capacity	Collet: 6mm or 1/4"
Max Wheel Diameter	19mm
No Load Speed (RPM)	28,000
Diameter of grip	65mm
Circumference of Grip	203mm
Dimensions (L x W x H)	289x64x67mm (11-3/8"x2-1/2"x2-5/8")
Net Weight	0.97kg (2.1lbs)
Power Supply Cord	2.5m (8.2ft)

**6**  
Spanner 10 (x2), Wheel points

**GD0800C** 8mm (1/4") Die Grinder

High-speed die grinder with max. 8mm collet capacity

318

**110V**  
**GD0800C/B**



Continuous Rating Input	750W
Capacity	Collet: 3,6,8mm or 1/8", 1/4"
Wheel Diameter	25 mm (1")
No Load Speed (RPM)	7,000-28,000
Dimensions (L x W x H)	371x75x75mm (14-5/8"x2-15/16"x2-15/16")
Net Weight	1.88kg (4.14lbs)
Power Supply Cord	2.5m (8.2ft)

Tool does not come with depressed center wheel

**5**  
Wrench x2

**GS5000** 125mm (5") Straight Grinder

"Tool-less" guard cap removal for more convenient wheel changes

204

**110V**  
**GS5000/B**



Continuous Rating Input	750W
Wheel Diameter	125 mm (5")
Hole Diameter	12.7,20mm (1/2,13/16")
No Load Speed (RPM)	5,600
Dimensions (L x W x H)	590x189x116mm (23-1/4"x7-7/16"x4-9/16")
Net Weight	5.0 - 5.2kg (11.0 - 11.5 lbs)
Power Supply Cord	2.5m (8.2ft)

**1**

**GB602** 150mm (6") Bench Grinder

Steady tool maintenance from this light, yet stable performer



Continuous Rating Input	250W
Wheel Diameter	150 mm (6")
Wheel Width	16mm (5/8")
Hole Diameter	12.7mm (1/2")
H.P.	1/3
No Load Speed (RPM)	2,850 (50Hz) / 3,450 (60Hz)
Dimensions (L x W x H)	375x348x286mm (14-49/64"x 13-45/64"x11-17/64")
Net Weight	9.5kg

**1**  
Eye Shield, Protection Glasses, Grinding wheel x 2

**GB801** 205mm (8") Bench Grinder

Steady tool maintenance from this light, yet stable performer



Continuous Rating Input	550W
Wheel Diameter	205 mm (8")
Wheel Width	19mm (3/4")
Hole Diameter	15.88mm (5/8")
H.P.	3/4
No Load Speed (RPM)	2,850 (50Hz) / 3,450 (60Hz)
Dimensions (L x W x H)	395x265x333mm (15-9/16"x 10-7/16"x13-7/64")
Net Weight	19.91 - 19.65kg (43.89 - 43.28lbs)

**1**  
Eye Shield, Protection Glasses, Grinding wheel x 2



PRODUCTS

SAWING

LS003GZ 305mm (12") Cordless Slide Compound Miter Saw

New

LED light with ink line aligning function

Li-ion Ah 8.0 | 5.0 | 4.0 | 2.5 | 2.0



Blade Diameter	305 mm (12")
Miter Angle	60° L / 60° R
Bevel Angle	48° L / 48° R
Max Cutting Capacity	90° Miter: 107 x 363 mm (4-1/4 x 14-1/4") 90° Miter: 92 x 382 mm (3-5/8 x 15") 45° Miter, L/R: 107 x 255 mm (4-1/4 x 10") 45° Miter, L/R: 92 x 268 mm (3-5/8 x 10-1/2")
No Load Speed (RPM)	3,600
Dimensions (L x W x H)	898 x 690 x 725 mm
Net weight	30.0 - 30.6 kg (66.1 - 67.5 lbs.)

40Vmax



XGT B.L. AWS DXT

TCT Saw Blade, Dust Bag, Triangular Rule, Vertical Vise, Hex Wrench, Battery, Charger, Z: Battery and Charger are sold separately

LS004GZ 260mm (10-1/4") Cordless Slide Compound Miter Saw

New

LED light with ink line aligning function

Li-ion Ah 8.0 | 5.0 | 4.0 | 2.5 | 2.0



Blade Diameter	260 mm (10-1/4")
Miter Angle	60° L / 60° R
Bevel Angle	48° L / 48° R
Max Cutting Capacity	90° Miter: 68 x 310 mm (2-11/16 x 12-1/4") 91 x 279 mm (3-5/8 x 11") 45° Miter, L/R: 68 x 218 mm (2-11/16 x 8-5/8") 91 x 197 mm (3-5/8 x 7-3/4")
No Load Speed (RPM)	3,600
Dimensions (L x W x H)	805 x 644 x 660 mm
Net weight	26.6 - 27.2 kg (58.6 - 60.0 lbs.)

40Vmax



XGT B.L. AWS DXT

TCT Saw Blade, Dust Bag, Triangular Rule, Vertical Vise, Hex Wrench, Wireless unit set, Battery, Charger, Z: Battery and Charger are sold separately

Cordless Slide Compound Miter Saw

LS003G / LS004G

Precise cutting and Smooth cutting



LED lamp to cast an exact cutting line



Easy locking and release of bevel angle



Rail-forward design enables to be placed against a wall for maximizing work space.

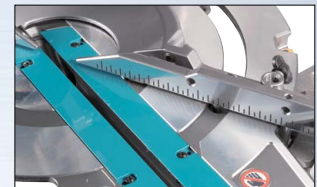

high precision cut



AWS connects to power tool with Bluetooth



Switch to start up vacuum cleaner (via AWS)



convenient for cleaning after working with this tool

Easy locking and release of bevel angle

Bevel angle can be locked/released by turning the dial behind the front grip, which is located near operator.



Positive stop function can be disabled simply by depressing a lever.



Max. cutting capacity (height x width)

LS003G 92 x 382 mm

LS004G 68 x 310 mm

### LS002GZ 216mm (8-1/2") Cordless Slide Compound Miter Saw

More efficient dust extraction

Li-ion Ah 8.0 5.0 4.0 2.5 2.0



Blade Diameter	216 mm (8-1/2")
Miter Angle	60° L / 60° R
Bevel Angle	48° L / 48° R
Max Cutting Capacity	90° Miter: 70 x 312 mm (2-3/4 x 12-1/4")
No Load Speed (RPM)	4,800
Dimensions (L x W x H)	702 x 551 x 557 mm (27-5/8 x 21-3/4 x 22")
Net weight	16.4 - 17.0 kg (36.2 - 37.6 lbs.)

40Vmax



LXT BL AWS DXT

TCT Saw Blade, Dust Bag, Triangular Rule, Vertical Vise, Hex Wrench, Battery, Charger, Z: Battery and Charger are sold separately

### DLS211Z 305mm (12") Cordless Slide Compound Miter Saw

Rail-forward design enables to be placed against a wall for maximizing work space

Li-ion Ah 6.0 5.0 3.0 1.5



Blade Diameter	305 mm (12")
Miter Angle	60° L / 60° R
Bevel Angle	48° L / 48° R
Max Cutting Capacity	90° Miter: 107 x 363 mm 90° Miter: 92 x 382 mm 45° Miter, L/R: 107 x 255 mm 45° Miter, L/R: 92 x 268 mm
No Load Speed (RPM)	4,400
Dimensions (L x W x H)	898 x 664 x 725 mm (35-1/4 x 26-1/8 x 28-1/2")
Net weight	28.3 - 28.9 kg (62.2 - 63.6 lbs.)

18V x2



LXT BL AWS ADT DXT

TCT Saw Blade, Dust Bag, Triangular Rule, Vertical Vise, Hex Wrench, Z: Battery and Charger are sold separately

### DLS714PT2 / Z 190mm (7-1/2") Cordless Slide Compound Miter Saw

4-Steel Rail Sliding System increases rigidity to produce superior cuts

Li-ion Ah 6.0 5.0 3.0 1.5



Blade Diameter	5,700
Max Cutting Capacity	90°: 52 x 300 mm (2-1/16" x 11-3/4") at 45° left: 40 x 300 mm (1-9/16" x 11-3/4") at 5° right: 40 x 300 mm (1-9/16" x 11-3/4")
No Load Speed (RPM)	190 mm (7-1/2")
Sound Power Level	97dB(A)
Dimensions (L x W x H)	655 x 430 x 445 mm (25-3/4" x 17" x 17-1/2")
Net weight	12.6 kg (27.8 lbs)

18V x2



LXT BL ADT

Fast Charger, TCT Saw Blade, Vertical Vise, Battery cartridge, Triangular Rule, Dust Bag, Holder set, Z: Battery and Charger are sold separately

### LS0714 190mm (7-1/2") Slide Compound Saw

Compact and Lightweight for Increased Jobsite Portability

303



Continuous Rating Input	1,010W
Max Cutting Capacity	90°: 52 x 300 mm (2-1/16" x 11-3/4") 45°: 52 x 212 mm (2-1/16" x 8-3/8")
Blade Diameter	190 mm (7-1/2")
No Load Speed (RPM)	6,000
Sound Power Level	101 dB(A)
Dimensions (L x W x H)	670 x 430 x 458 mm (26-3/8" x 17" x 18")
Net Weight	13.1 kg (28.9 lbs)
Power Supply Cord	2.5m (8.2ft)



TCT Saw Blade, Socket Wrench, Dust Bag, Holder Set, Vertical Vise, Triangular Rule

### LS1018L 260mm (10-1/4") Slide Compound Saw

Bevel cutting 45 degrees left and right

JM23000123



Continuous Rating Input	1,430W
Max Cutting Capacity	90°: 91 x 305 mm (3-5/8" x 12") 45°: 91 x 215 mm (3-5/8" x 8-1/2")
Blade Diameter	255 - 260 mm (10 - 10-1/4")
No Load Speed (RPM)	4,300
Sound Power Level	103 dB(A)
Dimensions (L x W x H)	825 x 536 x 633 mm (32-1/2" x 21-1/8" x 25")
Net Weight	20.6 kg (45.4 lbs)
Power Supply Cord	2.5m (8.2ft)



Carbide-Tipped Saw Blade, Vertical Vise, Socket Wrench, Triangular Rule, Dust Bag, Holder Assembly

### LS1019L 260mm (10-1/4") Slide Compound Miter Saw, Laser

260 mm (10-1/4") 1,510 W DXT Dual Slide Compound Miter Saw, Laser

153



Continuous Rating Input	1,510W
Blade Diameter	260 mm (10-1/4")
Bevel Angle	48° L / 48° R
Miter Angle	60° L / 60° R
Max Cutting Capacity (Bevel/Miter)	90°/90°: 68 / 310 mm 90°/90°/91°/279 mm (3-5/8" / 11") 90°/45°/45°: 68 / 218 mm 90°/45°/45°: 91 / 197 mm (3-5/8" / 7-3/4")
No Load Speed (RPM)	3,200
Dimensions (L x W x H)	805 x 644 x 660 mm (31-3/4" x 25-3/8" x 26")
Net Weight	26.3 kg (57.9 lbs.)
Power Supply Cord	2.5 m (8.2 ft.)



Dust Bag, Triangular Rule, Vertical Vise, Socket Wrench, Hex Wrench, Holder

### LS1219L 305mm (12") Slide Compound Miter Saw

305 mm (12") 1,800 W Slide Compound Miter Saw, Laser

153



Continuous Rating Input	1,800W
Blade Diameter	305 mm (12")
Bevel Angle	48° L / 48° R
Miter Angle	60° L / 60° R
Max Cutting Capacity	90°: 107 x 363 mm (4-1/4" x 14-1/4") 45°: 107 x 255 mm (4-1/4" x 10")
No Load Speed (RPM)	3,200
Dimensions (L x W x H)	898 x 644 x 725 mm (35-1/4" x 25-3/8" x 28-1/2")
Net Weight	29.3 kg (64.6 lbs)
Power Supply Cord	2.5 m (8.2 ft.)



Vertical Vise, Hex Wrench, Triangular Rule, Dust Bag

### DLS600Z 165mm (6-1/2") Cordless Compact Compound Saw

ADT Cordless Compound Miter Saw with LED Light

Li-ion Ah 6.0 5.0 3.0 1.5



Blade Diameter	165 mm (6-1/2")
Miter Angle	52° L / 52° R
Bevel Angle	46° L / 46° R
Max Cutting Capacity	90° Miter: 46 x 92 mm (1-13/16" x 3-5/8")
No Load Speed (RPM)	5,000
Sound Power Level	97 dB(A)
Dimensions (L x W x H)	340 x 400 x 440 mm (13-3/8" x 15-3/4" x 17-1/4")
Net weight	6.3 - 6.6 kg (13.9 - 14.6 lbs)

18V

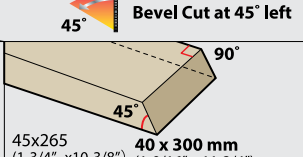
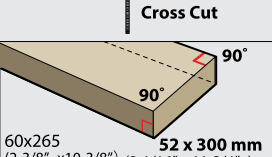
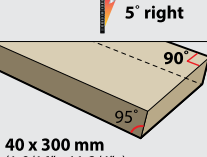
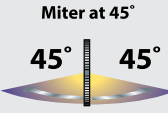
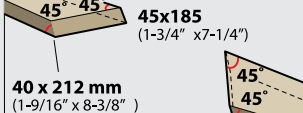
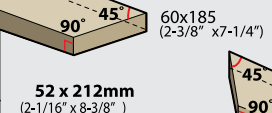
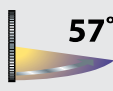
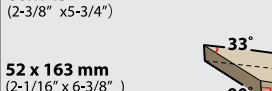

TCT Saw Blade, Dust Bag, Vertical Vise, Hex Wrench, Triangular Rule, Z: Battery and Charger are sold separately

	45° Bevel Cut at 45° left	Cross Cut	5° right
<b>Miter at 0°</b>  With a 20mm(3/4") auxiliary wood fence 45x265 (1-3/4" x 10-3/8") 40 x 300 mm (1-9/16" x 11-3/4")	 45x185 (1-3/4" x 7-1/4") 40 x 212 mm (1-9/16" x 8-3/8")	 60x265 (2-3/8" x 10-3/8") 52 x 300 mm (2-1/16" x 11-3/4")	 40 x 300 mm (1-9/16" x 11-3/4")
<b>Miter at 45°</b>  With a 15mm(3/5") auxiliary wood fence 45° 45° 45x185 (1-3/4" x 7-1/4") 40 x 212 mm (1-9/16" x 8-3/8")	 45x185 (1-3/4" x 7-1/4") 40 x 212 mm (1-9/16" x 8-3/8")	 60x185 (2-3/8" x 7-1/4") 52 x 212 mm (2-1/16" x 8-3/8")	-
<b>Miter at 57°</b>  With a 10mm(3/8") auxiliary wood fence 57°	-	 60x145 (2-3/8" x 5-3/4") 52 x 163 mm (2-1/16" x 6-3/8")	-

**LS1040 260mm (10-1/4") Compound Miter Saw**

Robust construction for consistently accurate cuts

153 W



Carbide-tipped saw blade, Vise assembly, Dust bag, Socket wrench 13, Triangular rule, Sub plate assembly, Holder x 2

Continuous Rating Input	1,650W
Max Cutting Capacity	90°: 90.5 x 95 mm (3-9/16" x 3-3/4") 45°: 90.5 x 67 mm (3-9/16" x 2-5/8")
Blade Diameter	260 mm (10-1/4")
No Load Speed (RPM)	4,600
Sound Power Level	106 dB(A)
Dimensions (L x W x H)	530x476x532mm (20-7/8"x18-3/8"x21")
Net Weight	12.4kg (27.3lbs)
Power Supply Cord	2.5m (8.2ft)

Tool does not come with saw blade

**LS1440 355mm (14") Miter Saw**

Clean miter cutting up to 45 degrees, right or left

153 W



Socket Wrench, Vise Assembly, Dust Bag, Holder Set

Continuous Rating Input	1,380W
Max Cutting Capacity	90°: 122 x 152 mm (4-13/16" x 6") 45°: 122 x 115 mm (4-13/16" x 4-1/2")
Blade Diameter	355 mm (14")
No Load Speed (RPM)	3,200
Dimensions (L x W x H)	530x596x435mm (20-7/8"x23-1/2"x17-1/8")
Net Weight	34.2kg (75.4lbs)
Power Supply Cord	2.5m (8.2ft)

Tool does not come with saw blade

**LH1201FL 305mm (12") Table Top Miter Saw**

Max. cutting width up to 200mm

JM23000123 W



Carbide-tipped saw blade, Vertical vise, Dust bag, Guide rule, Ring, Triangular rule, Push stick, Blade cover, Socket wrench, Holder set

Continuous Rating Input	1,650W
Blade Diameter	305 mm (12")
Miter Angle	47° L / 52° R
Bevel Angle	45° L
Max Cutting Capacity	90°: 62x200mm(2-7/16"x7-7/8") 90°: 95 x 155 mm (3-3/4" x 6-1/8") 45° Miter, L/R: 62x135 mm (2-7/16"x5-1/16") 45° Miter, L/R: 95x110 mm (3-3/4"x4-5/16") 90°: Tablesaw: 52 mm (2-1/16")
No Load Speed (RPM)	3,800
Sound Power Level	106 dB(A)
Table Size (W x L)	307 x 465 mm (12-1/8" x 18-1/4")
Net Weight	20.9 kg (46.1 lbs)
Power Supply Cord	2.5 m (8.2 ft)

**MLT100 260mm (10-1/4") Table Saw**

Sliding left extension sub-table is provided

JM23000123 W



TCT Saw Blade, Rip Fence, Miter Gauge, Wrenches, Push Stick, Triangular Rule

Continuous Rating Input	1,500W
Max Cutting Capacity	0°: 93 mm (3-5/8") 45°: 64 mm (2-1/2")
Blade Diameter	260 mm (10-1/4")
No Load Speed (RPM)	4,300
Dimensions (L x W x H)	726x984x333mm (28-1/2"x38-3/4"x13-1/8")
Net Weight	34.1kg (75.2lbs)
Power Supply Cord	2.5m (8.2ft)

\*Comes with JM27000300 (1 unit)

**2712 315mm (12-3/8") Table Saw**

315mm table saw with induction motor



Tct Saw Blade, Rip Fence, Miter Gauge, Wrenches, Push Stick, Ring

Max Cutting Capacity	0°: 85 mm (3-3/8") 45°: 58 mm (2-1/4")
Blade Diameter	315 mm (12-3/8")
No Load Speed (RPM)	50Hz: 2,950 60Hz: 3,400
Bevel Cutting Capacity	0 - 45
Dimensions (L x W x H)	1,670x700x810mm (65-3/4"x27-1/2"x32")
Net Weight	54kg (118.9lbs)
Power Supply Cord	3.0m (9.8ft)

**SJ401 Scroll Saw**

Bevel cuts up to 45 degrees to the left and 15 degrees to the right

375009-001 W



Saw Blades 6, Hex Wrench, Blade Change Rod

Continuous Rating Input	50W
Capacity	Thickness of cut : 50mm (2") Throat : 406mm (16") 18 mm (11/16")
Length of Stroke	18 mm (11/16")
Strokes Per Minute (SPM)	400-1,600
Overall Length	600 mm (23-5/8")
Net Weight	14.1kg (31lbs)



**LB1200F 305mm (12") Band Saw**

305mm Band Saw with high cutting efficiency



Continuous Rating Input Capacity	900W Thickness of cut: 165mm (6-1/2") Throat : 305mm (12")
Blade Speed High	(50Hz)800 (60Hz)1,000m (50Hz)2,624 (60Hz)3,280ft) / min
Blade Speed Low	(50Hz)400 (60Hz)500m (50Hz)1,312 (60Hz)1,640ft) / min
Dimensions (L x W x H)	615x775x1,600mm (24-1/4"x30-1/2"x63")
Net Weight	82kg (181.2lbs)
Power Supply Cord	2.5m (8.2ft)



Saw Blades 6, Hex Wrench, Blade Change Rod



**PRODUCTS**

**CIRCULAR SAW**

**SP001GZ 165mm (6-1/2") Cordless Plunge Cut Saw**

**New**

BL motor delivers 4,900 RPM for fast cutting and ripping

Li-ion Ah 8.0 5.0 4.0 2.5 2.0



Blade Diameter	165 mm (6-1/2")
Max Cutting Capacity	0°: 56 mm (2-3/16") 45°: 40 mm (1-9/16") 48°: 38 mm (1-1/2")
No Load Speed (RPM)	2,500 - 4,900
Sound Power Level	100 dB(A)
Dimensions (L x W x H)	347 x 221 x 271 mm (13-5/8 x 8-3/4 x 10-5/8")
Net weight	4.4 - 5.0 kg (9.7 - 11.0 lbs.)

40Vmax



TCT Saw Blade, Hex Wrench, Wireless Unit (country-specific), Battery, Charger, Z: Battery and Charger are sold separately

**DSP600Z 165mm (6-1/2") Cordless Plunge Cut Saw**

18V X2 (36V) LXT BL Cordless 165 mm (6-1/2") Plunge Cut Saw

Li-ion Ah 6.0 5.0 3.0 1.5



Blade Diameter	165 mm (6-1/2")
Max Cutting Capacity	90°: 56 mm (2-3/16") 45°: 40 mm (1-9/16") 48°: 38 mm (1-1/2")
No Load Speed (RPM)	2,500 - 6,300
Sound Power Level	103 dB(A)
Dimensions (L x W x H)	346x241x272 mm (13-5/8"x9-1/2"x10-3/4")
Net weight	4.4 - 5.1 kg (9.8 - 11.2 lbs)

18V x2



Blade, Blade Cover, Base Cover, Hex Wrench, Z: Battery and Charger are sold separately

**DSP601Z 165mm (6-1/2") Cordless Plunge Cut Saw**

18V X2 (36V) LXT BL Cordless 165 mm (6-1/2") Plunge Cut Saw

Li-ion Ah 6.0 5.0 3.0 1.5



Blade Diameter	165 mm (6-1/2")
Max Cutting Capacity	90°: 56 mm (2-3/16") 45°: 40 mm (1-9/16") 48°: 38 mm (1-1/2")
No Load Speed (RPM)	2,500 - 6,300
Sound Power Level	103 dB(A)
Dimensions (L x W x H)	346x241x272 mm (13-5/8"x9-1/2"x10-3/4")
Net weight	4.4 - 5.1 kg (9.8 - 11.2 lbs)

18V x2



Blade, Blade Cover, Base Cover, Hex Wrench, Z: Battery and Charger are sold separately

**SP6000J 165mm (6-1/2") Plunge Cut Circular Saw**

Light duty model with continuous input 450W

303



Continuous Rating Input	1,300W
Blade Diameter	165 mm (6-1/2")
Max Cutting Capacity	90°: 56 mm (2-3/16") 45°: 40 mm (1-9/16") 48°: 38 mm (1-1/2")
No Load Speed (RPM)	2,200 - 6,400
Dimensions (L x W x H)	341x225x250mm (13-3/8"x8-7/8"x9-7/8")
Net Weight	4.1 kg (9lbs)
Power Supply Cord	2.5m (8.2ft)



Carbide-tipped saw blade. Hex wrench

**HS009GZ 235mm (9-1/4") Cordless Circular Saw**

**New**

40Vmax XGT BL AWS Cordless 235 mm (9-1/4") Magnesium Circular Saw

Li-ion Ah 8.0 5.0 4.0 2.5 2.0



Wheel Diameter	235 mm (9-1/4")
Hole Diameter	15.88 / 25 / 25.4 / 30 mm (5/8" / 1" / 1-3/16")
Blade Body Thickness	1.4 - 1.8 mm
Max Cutting Capacity	0°: 85 mm (3-3/8") 45°: 61 mm (2-3/8") 60°: 44 mm (1-3/4")
No Load Speed (RPM)	4,000
Max Output	1,600 W
Dimensions (L x W x H)	413 x 196 x 316 mm (16-1/4" x 7-3/4" x 12-1/2")
Net weight	5.1 - 5.7 kg (11.2 - 12.6 lbs.)

40Vmax



TCT Saw Blade, Sub Base, Hex Wrench, Battery, Charger, Z: Battery and Charger are sold separately

**HS010GZ 235mm (9-1/4") Cordless Circular Saw**

**New**

40Vmax XGT BL AWS Cordless 235 mm (9-1/4") Circular Saw

Li-ion Ah 8.0 5.0 4.0 2.5 2.0



Wheel Diameter	235 mm (9-1/4")
Hole Diameter	25 / 25.4 / 30 mm (1" / 1-3/16")
Blade Body Thickness	1.4 - 1.8 mm
Max Cutting Capacity	0°: 85 mm (3-3/8") 45°: 61 mm (2-3/8") 60°: 41 mm (1-5/8")
No Load Speed (RPM)	4,000
Max Output	1,600 W
Dimensions (L x W x H)	430 x 224 x 316 mm (17 x 8-7/8" x 12-1/2")
Net weight	5.5 - 6.1 kg (12.1 - 13.4 lbs.)

40Vmax



TCT Saw Blade, Guide Rule, Hex Wrench, Battery, Charger, Z: Battery and Charger are sold separately

**HS003GM201(RM2) / GZ 190mm / 185mm (7-1/2" / 7-1/4") Cordless Circular Saw**

BL motor delivers 6,000 RPM for fast cutting

Li-ion Ah 8.0 5.0 4.0 2.5 2.0



Blade Diameter	190 / 185 mm (7-1/2" / 7-1/4")
Max Cutting Capacity	90°: 68.5 / 66 mm (2-11/16" / 2-5/8") 45°: 47.5 / 45.5 mm (1-7/8" / 1-13/16") 56°: 35.5 / 34 mm (1-3/8" / 1-5/16")
No Load Speed (RPM)	6,000
Dimensions (L x W x H)	w/ BL4025: 316x200x290 mm (12-1/2" x 7-7/8" x 11-3/8") w/ BL4040: 331x200x290 mm (13" x 7-7/8" x 11-3/8")
Net weight	4.1 - 4.4 kg (9.0 - 9.7 lbs.)

40Vmax



TCT Saw Blade, Dust Nozzle, Hex Wrench, Battery, Charger, Z: Battery and Charger are sold separately

**HS004GM201(RM2) / GZ 190mm / 185mm (7-1/2" / 7-1/4") Cordless Circular Saw**

BL motor delivers 6,000 RPM for fast cutting

Li-ion Ah 8.0 5.0 4.0 2.5 2.0



Blade Diameter	190 / 185 mm (7-1/2" / 7-1/4")
Max Cutting Capacity	90°: 62.5 / 60 mm (2-7/16" / 2-3/8") 45°: 44.5 / 43 mm (1-3/4" / 1-11/16") 48°: 42 / 41 mm (1-5/8" / 1-5/8")
No Load Speed (RPM)	6,000
Dimensions (L x W x H)	w/ BL4025: 322x210x290 mm (12-5/8" x 8-1/4" x 11-3/8") w/ BL4040: 337x210x290 mm (13-1/4" x 8-1/4" x 11-3/8")
Net weight	4.4 - 4.7 kg (9.7 - 10.4 lbs.)

40Vmax



TCT Saw Blade, Dust Nozzle, Hex Wrench, Guide Rule, Battery, Charger, Z: Battery and Charger are sold separately



**DHS900Z 235mm (9-1/4") Cordless Circular Saw**

Magnesium Circular Saw, Electric Brake, Soft Start, Twin LED Light

Li-ion Ah 6.0 5.0 3.0 1.5



Blade Diameter	235 mm (9-1/4")
Max Cutting Capacity	90°: 85 mm (3-3/8") 45°: 61 mm (2-3/8") 60°: 44 mm (1-3/4")
No Load Speed (RPM)	6,000
Dimensions (L x W x H)	413x196x316 mm (16-1/4" x 7-3/4" x 12-1/2")
Net weight	5.3 - 6.0 kg (11.7 - 13.2 lbs.)

18V x2



Wireless Unit (country-specific), TCT Saw Blade, Sub Base, Hex Wrench, Battery, Charger, Z: Battery and Charger are sold separately

**DHS783Z 190mm / 185mm (7-1/2" / 7-1/4") Cordless Circular Saw**

Magnesium Circular Saw, Electric Brake, Soft Start, Dual LED Light

Li-ion Ah 6.0 5.0 3.0 1.5



Blade Diameter	190 / 185 mm (7-1/2" / 7-1/4")
Max Cutting Capacity	90°: 62.5 / 60 mm (2-7/16" / 2-3/8") 45°: 44.5 / 43 mm (1-3/4" / 1-11/16") 48°: 42 / 41 mm (1-5/8" / 1-5/8")
No Load Speed (RPM)	6,000
Dimensions (L x W x H)	348x210x290 mm (13-3/4" x 8-1/4" x 11-3/8")
Net weight	4.5 - 5.1 kg (9.9 - 11.3 lbs.)

18V x2



Wireless Unit (country-specific), TCT Saw Blade, Dust Nozzle, Hex Wrench, Guide Rule, Hook, Battery, Charger, Z: Battery and Charger are sold separately

**DHS782Z 190mm / 185mm (7-1/2" / 7-1/4") Cordless Circular Saw**

Magnesium Circular Saw, Electric Brake, Soft Start, Dual LED Light

Li-ion Ah 6.0 5.0 3.0 1.5



Blade Diameter	190 / 185 mm (7-1/2" / 7-1/4")
Max Cutting Capacity	90°: 62.5 / 60 mm (2-7/16" / 2-3/8") 45°: 44.5 / 43 mm (1-3/4" / 1-11/16") 48°: 42 / 41 mm (1-5/8" / 1-5/8")
No Load Speed (RPM)	6,000
Dimensions (L x W x H)	348x210x290 mm (13-3/4" x 8-1/4" x 11-3/8")
Net weight	4.5 - 5.1 kg (9.9 - 11.3 lbs.)

18V x2



TCT Saw Blade, Dust Nozzle, Hex Wrench, Guide Rule, Hook, Battery, Charger, Z: Battery and Charger are sold separately

## DHS710Z 190mm / 185mm (7-1/2" / 7-1/4") Cordless Circular Saw

Makita-built motor delivers 4,800 RPM for fast cutting and ripping

442

Li-ion Ah 6.0 5.0 3.0 1.5



Blade Diameter	190 / 185 mm (7-1/2" / 7-1/4")
Max Cutting Capacity	90°: 68.5 / 66 mm (2-11/16" / 2-5/8") 45°: 49 / 47.5 mm (1-15/16" / 1-7/8") 50°: 44 / 42.5 mm (1-3/4" / 1-11/16")
No Load Speed (RPM)	4,800
Dimensions (L x W x H)	356 x 217 x 298 mm (14 x 8-1/2 x 11-3/4")
Net weight	3.9 - 4.6 kg (8.6 - 10.1 lbs.)

18V x2



TCT Saw Blade, Rip Fence (Guide Rule), Hex Wrench, Dust Nozzle (country-specific), Battery, Charger, Z: Battery and Charger are sold separately

## DHS661RGJ / Z 165mm (6-1/2") Cordless Circular Saw

Compact and Lightweight

Li-ion Ah 6.0 5.0 3.0 1.5

DHS661RGJ  
1  
DHS661Z  
2

Blade Diameter	165 mm (6-1/2")
Hole Diameter	15.88 / 20 mm (5/8" / 13/16")
Max Cutting Capacity	90°: 57 mm (2-1/4"), 45°: 41 mm (1-5/8") 50°: 37 mm (1-7/16")
No Load Speed (RPM)	5,000
Sound Power Level	104 dB(A)
Dimensions (L x W x H)	270x186x250 mm (10-5/8"x7-3/8"x9-7/8")
Net weight	2.9 - 3.2 kg

18V



LXT BL AWS ADT XPT

TCT Saw Blade, Hex Wrench, Rip Fence (Guide Rule), Dust Nozzle, Battery, Fast Charger, Z: Battery and Charger are sold separately

## DHS660RGJ / Z 165mm (6-1/2") Cordless Circular Saw

Compact and Lightweight

Li-ion Ah 6.0 5.0 3.0 1.5

DHS660RGJ  
1  
DHS660Z  
1

Blade Diameter	165 mm (6-1/2")
Hole Diameter	15.88 / 20 mm (5/8" / 13/16")
Max Cutting Capacity	90°: 57 mm (2-1/4"), 45°: 41 mm (1-5/8") 50°: 37 mm (1-7/16")
No Load Speed (RPM)	5,000
Sound Power Level	104 dB(A)
Dimensions (L x W x H)	270x186x250 mm (10-5/8"x7-3/8"x9-7/8")
Net weight	2.9 - 3.2 kg (6.3 - 7.0 lbs.)

18V



LXT BL ADT XPT

TCT Saw Blade, Hex Wrench, Rip Fence (Guide Rule), Dust Nozzle, Battery, Fast Charger, Z: Battery and Charger are sold separately

## DSS610RTE / Z 165mm (6-1/2") Cordless Circular Saw

Lightweight and compact design

441

Li-ion Ah 6.0 5.0 3.0 1.5

DSS610RTE  
2  
DSS610Z  
1

Blade Diameter	165 mm (6-1/2")
Max Cutting Capacity	90°: 0-57 mm (2-1/4") 45°: 0-40 mm (1-9/16") 50°: 0-36 mm (1-7/16")
No Load Speed (RPM)	3,700
Dimensions (L x W x H)	347x202x228 mm (13-5/8"x8"x9")
Net weight	3.0 - 3.4 kg (6.7 - 7.5 lbs)

18V



Fast Charger, Battery Cartridge, Carbide-tipped Saw Blade, Guide Rule, Hex Wrench, Z: Battery and Charger are sold separately

## DSS501RTE / Z 136mm (5-3/8") Cordless Circular Saw

Well balanced tool design for high maneuverability

430

Li-ion Ah 6.0 5.0 3.0 1.5



Blade Diameter	136 mm (5-3/8")
Max Cutting Capacity	90°: 51 mm (2") 45°: 35 mm (1-3/8")
No Load Speed (RPM)	3,600
Dimensions (L x W x H)	364x183x201 mm (14-3/8"x7-1/4"x7-7/8")
Net weight	2.4 - 2.7 kg (5.3 - 6.0 lbs)

18V



Fast Charger, Battery Cartridge, Carbide-tipped Saw Blade, Guide Rule, Hex Wrench, Z: Battery and Charger are sold separately



## HS301DWAE / DZ 85mm (3-3/8") Cordless Circular Saw

High power, high cutting efficiency

Li-ion Ah 4.0 2.0 1.5



Blade Diameter	85 mm (3-3/8")
Max Cutting Capacity	90°: 25.5 mm (1") 45°: 16.5 mm (5/8")
No Load Speed (RPM)	1,500
Max Output	160W
Dimensions (L x W x H)	313x170x155mm (12-3/8"x6-11/16"x6-1/8")
Net Weight	1.6 - 1.7kg (3.5 - 3.8lbs)

HS301DWAE HS301DZ

3 4

12Vmax



TCT saw blade, Hex wrench, Battery, Charger, DZ: Battery and Charger are sold separately

## HS300DW / DZ 85mm (3-3/8") Cordless Circular Saw

Lightweight and Compact design

Li-ion Ah 1.3



Blade Diameter	85 mm (3-3/8")
Max Cutting Capacity	90°: 25.5 mm (1") 45°: 16.5 mm (5/8")
No Load Speed (RPM)	1,400
Dimensions (L x W x H)	300x170x154mm (11-3/4"x6-11/16"x6-1/8")
Net Weight	1.5 kg (3.3 lbs)

10.8V



Charger, Battery Cartridge, T.C.T Saw Blade, Hex Wrench, DZ: Battery and Charger are sold separately



**HS6600 165mm (6-1/2") Circular Saw**

Powerful 1,050 W motor delivers 5,200 RPM for performance

303



Continuous rating Input	1,050W
Blade Diameter	165 mm (6-1/2")
Hole Diameter	15.88, 20, 25.4, 30 mm (5/8, 13/16, 1, 1-3/16")
Max Cutting Capacity	0° : 54.5 mm (2-1/8") 45° : 37.5 mm (1-1/2")
No Load Speed (RPM)	5,200
Dimensions (L x W x H)	296 x 230 x 243 mm (11-5/8 x 9 x 9-9/16")
Net Weight	3.5 kg (7.6 lbs.)
Power supply cord	2.5 m (8.2 ft)



Rip Fence (Guide Rule), TCT Saw Blade, Hex Wrench

**5806B 185mm (7-1/4") Circular Saw**

Sawdust and chips hardly ever come near operator

303



110V  
5806B/B

Continuous Rating Input	1,050W
Blade Diameter	185 mm (7-1/4")
Max Cutting Capacity	90°: 66 mm (2-5/8") 45°: 44 mm (1-11/16")
No Load Speed (RPM)	5,200
Overall Length	282 mm (11-1/8")
Net Weight	3.5kg (7.6lbs)
Power Supply Cord	2.5m (8.2ft)



Carbide-Tipped Saw Blade, Hex Wrench, Rip Fence (Guide Rule)

**HS7600 185mm (7-1/4") Circular Saw**

New aesthetic design with Soft grip

303



Continuous Rating Input	1,200W
Blade Diameter	185 mm (7-1/4")
Max Cutting Capacity	90°: 64 mm (2-1/2") 45°: 42 mm (1-5/8")
No Load Speed (RPM)	5,200
Vibration Level	Cutting Wood: 2.5 m/s <sup>2</sup> or less
Sound Power Level	98 dB(A)
Dimensions (L x W x H)	309x234x255mm (12-1/8"x9-1/4"x10")
Net Weight	3.8 kg (8.3 lbs)
Power Supply Cord	2.5 m (8.2 ft)



TCT Saw Blade, Hex wrench, Rip fence (guide rule)

**HS7010 190mm / 185mm (7-1/2" / 7-1/4") Circular Saw**

185 mm (7-1/4") / 190 mm (7-1/2") 1,600 W Circular Saw

303



Continuous Rating Input	1,600W
Blade Diameter	185 / 190 mm (7-1/4" / 7-1/2")
Max Cutting Capacity	90°: 65 / 67 mm (2-9/16" / 2-5/8") 45°: 44 / 45 mm (1-3/4" / 1-3/4")
No Load Speed (RPM)	5,500
Dimensions (L x W x H)	300x240x261 mm (11-3/4"x9-1/2"x10-1/4")
Net Weight	4.0 kg (8.9 lbs)
Power Supply Cord	2.5 m (8.2 ft)



TCT Saw Blade, Rip Fence (Guide Rule), Hex Wrench, Dust Nozzle (country-specific)

**5008MG 210mm (8-1/4") Circular Saw**

Maximum cutting depth of 75.5mm (3")

153



Continuous Rating Input	1,800W
Blade Diameter	210 mm (8-1/4")
Max Cutting Capacity	90°: 75.5 mm (3") 45°: 57 mm (2-1/4") 50°: 51.5 mm (2")
No Load Speed (RPM)	5,200
Dimensions (L x W x H)	332x243x277mm (13-1/8"x9-9/16"x10-7/8")
Net Weight	4.8kg (10.6lbs)
Power Supply Cord	2.5m (8.2ft)



TCT Saw Blade, Hex Wrench, Rip Fence (Guide Rule)

**N5900B 235mm (9-1/4") Circular Saw**

Bevel cuts up to 50 degrees

153



Continuous Rating Input	2,000W
Blade Diameter	235 mm (9-1/4")
Max Cutting Capacity	90°: 85 mm (3-3/8") 45°: 60 mm (2-3/8") 50°: 53 mm (2-1/16")
No Load Speed (RPM)	4,100
Overall Length	380 mm (15")
Net Weight	6.8kg (14.8lbs)
Power Supply Cord	2.5m (8.2ft)



T.C. T Saw Blade, Grip, Wrench & Rip Fence

**HS0600 270mm / 260mm (10-5/8" / 10-1/4") Circular Saw**

270 mm (10-5/8") 2,000 W Circular Saw

153



Continuous Rating Input	2,000W
Blade Diameter	260 - 270 mm (10-1/4" - 10-5/8")
Max Cutting Capacity	90°: 97 mm (3-13/16") 45°: 68 mm (2-11/16")
No Load Speed (RPM)	4,300
Sound Power Level	105 dB(A)
Dimensions (L x W x H)	418x273x324 mm (16-1/2"x10-3/4"x12-3/4")
Net Weight	6.9 kg (15.2 lbs)
Power Supply Cord	2.5 m (8.2 ft)



TCT Saw Blade, Hex Wrench, Rip Fence (Guide Rule)

**5103N 335mm (13-1/8") Circular Saw**

Huge cutting capacity with efficient control

153



Continuous Rating Input	1,750W
Blade Diameter	335 mm (13-1/8")
Max Cutting Capacity	90°: 128 mm (5") 45°: 91 mm (3-5/8")
No Load Speed (RPM)	2,900
Overall Length	505 mm (19-7/8")
Net Weight	8.9kg (19.6lbs)
Power Supply Cord	5.0m (16.4ft)



Combination Saw Blade, Wrench, Hex Wrench, Rip Fence (Guide Rule)

## PRODUCTS



## JIG SAW

## DJV182RTE / Z Cordless Jig Saw

Top handle type cordless jig saw powered by Li-ion batteries

Li-ion Ah 6.0 5.0 3.0 1.5

DJV182RTE  
2DJV182Z  
4

Capacity	Wood: 135 mm (5-5/16") Steel: 10 mm (3/8")
Length of Stroke	26 mm (1")
Strokes Per Minute (SPM)	800 - 3,500
Dimensions (L x W x H)	266x77x208 mm (10-1/2"x3"x8-3/16")
Net weight	2.4 - 2.7 kg (5.2 - 5.9 lbs)

Cutting capacity in wood: when cutting with optional blade No.B-16L

18V



Fast Charger, Battery Cartridge, Jig Saw Blade Assortment, Cover Plate, Anti-splintering Device, Hex Wrench, Z: Battery and Charger are sold separately

## DJV180RTE / Z Cordless Jig Saw

High accuracy and high efficiency

430

Li-ion Ah 6.0 5.0 3.0 1.5

DJV180Z  
5

Capacity	Wood: 135 mm (5-5/16") Steel: 10 mm (3/8")
Length of Stroke	26 mm (1")
Strokes Per Minute (SPM)	0-2,600
Dimensions (L x W x H)	257x73x208 mm (10-1/8"x2-7/8"x8-3/16")
Net weight	2.7 - 3.0 kg (6.0 - 6.7 lbs)

Cutting capacity in wood: when cutting with optional blade No.B-16L

18V



Fast Charger, Battery Cartridge, Jig Saw Blade Set (No. B-10, B-13, B-22; 2each), Cover Plate, Anti-splintering Device, Hex Wrench, Z: Battery and Charger are sold separately

## DJV184RTJ / Z Cordless Jig Saw

New

3 Orbital Settings Plus Straight Cutting, LED Light

Li-ion Ah 6.0 5.0 3.0 1.5



Capacity	Wood: 135 mm (5-5/16") Steel: 10 mm (3/8") Aluminum: 20 mm (25/32")
Length of Stroke	23 mm (7/8")
Strokes Per Minute (SPM)	0 - 3,000
Dimensions (L x W x H)	259 x 78 x 205 mm (10-1/4 x 3-1/16 x 8-1/8")
Net weight	2.1 - 2.5 kg (4.6 - 5.5 lbs.)

18V



Jig Saw Blade, Hex Wrench, Cover Plate, Dust Nozzle (country-specific), Dust Cover (country-specific), Battery, Charger, Z: Battery and Charger are sold separately

## JV103DSAJ / DZ Cordless Jig Saw

Disabling soft no-load rotation function in operator's preference

Li-ion Ah 4.0 2.0 1.5

JV103DSAJ  
1  
JV103DZ  
5

Max Cutting Capacity at 90°	Wood: 90mm (3-1/2") Aluminum: 20mm (13/16") Mild Steel: 10mm (3/8")
Length of Stroke	23 mm (7/8")
Strokes Per Minute (SPM)	800 - 3,000
Sound Power Level	96 dB(A)
Dimensions (L x W x H)	237x76x206 mm (9-3/8"x3"x8-1/8")
Net Weight	1.9 - 2.0 kg (4.1 - 4.4 lbs)

12Vmax



Jig Saw Blade, Hex Wrench, Cover Plate (country-specific), Dust Nozzle (country-specific), Dust Cover (country-specific), Battery, Charger, DZ: Battery and Charger are sold separately

## JV101DSAE / DZ Cordless Jig Saw

12Vmax CXT Li-Ion Cordless Top Handle Jig Saw

Li-ion Ah 4.0 2.0 1.5

JV101DSAE  
3  
JV101DZ  
5

Max Cutting Capacity at 90°	Wood: 65mm (2-9/16") Aluminum: 4mm (5/32") Mild Steel: 2mm (1/16")
Length of Stroke	18 mm (11/16")
Strokes Per Minute (SPM)	0-2,900
Sound Power Level	91 dB(A)
Dimensions (L x W x H)	232x76x196mm (9-1/8"x3"x7-3/4")
Net Weight	1.8 - 1.9kg (3.9 - 4.3lbs)

12Vmax



Jig Saw Blade, Hex Wrench, Guide Rule (country-specific), Battery, Charger, DZ: Battery and Charger are sold separately

## 4327M Jig Saw

High power and Lightweight

64



Jig Saw Blade, Hex Wrench

Continuous Rating Input Capacity	450W Wood: 40 mm (1-9/16") Steel: 6 mm (1/4")
Length of Stroke	18 mm (11/16")
Strokes Per Minute (SPM)	500 - 3,100
Dimensions (L x W x H)	224x77x197mm (8-7/8"x3"x7-3/4")
Net Weight	1.8 kg (4.0 lbs.)
Power Supply Cord	2.0m (6.6ft)

4300BV Jig Saw

Long-run best seller, this tool puts performance first

51



Continuous Rating Input	390W
Capacity	Wood: 55 mm (2-1/8") Steel: 6 mm (1/4")
Length of Stroke	26 mm (1")
Strokes Per Minute (SPM)	0-3,100
Overall Length	225 mm (8-7/8")
Net Weight	2.5kg (5.5lbs)
Power Supply Cord	2.5m (8.2ft)



Jig Saw Blade Set (No. 1, 2 & 3 : 2 each), Rip Fence (Guide Rule), Circular Guide Assembly, Blade Clamp Assembly, Hex Wrench

JV0600K Jig Saw

Powerful and Maneuverable

64



Continuous Rating Input	650W
Capacity	Wood: 90 mm (3-1/2") Steel: 10 mm (3/8")
Length of Stroke	23 mm (7/8")
Strokes Per Minute (SPM)	500 - 3,100
Dimensions (L x W x H)	236x77x199mm (9-1/4"x3"x7-7/8")
Net Weight	2.4kg (5.2lbs)
Power Supply Cord	2.5m (8.2ft)



Jig Saw Blade, Hex Wrench

PRODUCTS

PLANING & ROUTERING

KP001GZ 82mm (3-1/4") Cordless Planer

New

40Vmax XGT BL AWS ADT Cordless 82 mm (3-1/4") Planer

Li-ion Ah 8.0 | 5.0 | 4.0 | 2.5 | 2.0



Planing Width	82 mm (3-1/4")
Planing Depth	4 mm (5/32")
Shiplapping	25 mm (1")
No Load Speed (RPM)	15,000
Dimensions (L x W x H)	379 x 156 x 166 mm (14-7/8 x 6-1/8 x 6-1/2")
Net weight	3.8 - 4.4 kg (8.3 - 9.6 lbs.)

40Vmax



Planer Blade, Blade Gauge, Guide Rule, Depth Guide, Socket Wrench, Sharpening Holder Assembly (for resharpenable blade), Wireless Unit (country-specific), Battery, Charger, Z: Battery and Charger are sold separately

DKP181Z 82mm (3-1/4") Cordless Planer

High power BL motor delivers powerful cutting

Li-ion Ah 6.0 | 5.0 | 3.0 | 1.5



Planing Width	82 mm (3-1/4")
Planing Depth	3 mm (1/8")
Max Shiplapping	25mm (1")
No Load Speed (RPM)	12,000
Dimensions (L x W x H)	366x156x166 mm (14-3/8"x6-1/8"x6-1/2")
Net weight	3.3 - 3.6 kg (7.3 - 7.9 lbs.)

18V



Planer Blade, Blade Gauge, Guide Rule, Socket Wrench, Dust Nozzle, Z: Battery and Charger are sold separately

KP0800X 82mm (3-1/4") Power Planer

Angle and shape of handle are easy to grip, push and carry

411



Continuous Rating Input	620W
Planing Width	82 mm (3-1/4")
Planing Depth	2.5 mm (3/32")
No Load Speed (RPM)	17,000
Dimensions (L x W x H)	285x158x158mm (11-1/4"x6-1/4"x6-1/4")
Net Weight	2.8 kg (6.2 lbs)
Power Supply Cord	2.5 m (8.2 ft)



Blade Gauge Assembly, Guide Rule, Planer Blade, Socket Wrench, Sharpening Holder, Shiplapping: 9 mm (11/32")

N1900B 82mm (3-1/4") Power Planer

580W motor delivers more output power for increased performance

51



Continuous Rating Input	580W
Planing Width	82 mm (3-1/4")
Planing Depth	1 mm (1/32")
No Load Speed (RPM)	16,000
Overall Length	290 mm (11-3/8")
Net Weight	2.8 kg (6.1 lbs)
Power Supply Cord	2.5 m (8.2 ft)



Sharpening Holder Assembly, Blade Gauge Assembly, Socket Wrench, Planer Blade, Edge Fence (Guide Rule), Shiplapping : 23mm (29/32")



## 1911B 110mm (4-3/8") Power Planer

Planes up to 110mm (4-3/8") wide and 2mm (1/16") deep in a single pass 106 

Continuous Rating Input	840W
Planing Width	110 mm (4-3/8")
Planing Depth	2 mm (1/16")
No Load Speed (RPM)	16,000
Overall Length	355 mm (14")
Net Weight	4.3kg (9.5lbs)
Power Supply Cord	5.0m (16.4ft)



Sharpening Holder Assembly, Blade Gauge Assembly, Socket Wrench, Planer Blade

## 1805N 155mm (6-1/8") Power Planer

Rugged aluminum housing and easy depth settings 153 

Continuous Rating Input	1,140W
Planing Width	155 mm (6-1/8")
Planing Depth	2 mm (1/16")
No Load Speed (RPM)	15,000
Overall Length	445 mm (17-1/2")
Net Weight	7.9kg (17.3lbs)
Power Supply Cord	5.0m (16.4ft)



Sharpening Holder Assembly, Blade Gauge Assembly, Socket Wrench, Planer Blade

## 2012NB 304mm (12") Power Planer

Compact and lightweight for easier transport 153 

Continuous Rating Input	1,650W
Cutting Width	304 mm (12")
Cutting Depth	Cutting width 0-150mm: 3mm (1/8")
	Cutting width 150-240mm: 1.5mm (1/16")
Feed Rate/min.	8.5m (27.9ft)
Table Size (W x L)	304 x 771 mm (12" x 30-3/8")
No Load Speed (RPM)	8,500
Dimensions (L x W x H)	483x771x401mm (19"x30-3/8"x15-13/16")
Net Weight	28.1kg (61.9lbs)
Power Supply Cord	2.5m (8.2ft)



Socket Wrench, Hex Wrench, Magnetic Holders X2, Planer Blade 306

## DPJ180Z Cordless Plate Joiner

New top handle with flat shape on side surface for excellent tool control 430 

Blade Diameter	100 mm (4")
Max cutting depth	20 mm (3/4")
No Load Speed (RPM)	6,500
Dimensions (L x W x H)	351x139x149 mm (13-3/4"x5-1/2"x5-7/8")
Net weight	2.8 - 3.1 kg (6.2 - 6.8 lbs)



Cutter Blade, Angle Guide, Lock Nut Wrench, Set Plate, Dust Bag, Z: Battery and Charger are sold separately

## PJ7000 Plate Joiner

Cast aluminum pivot fence with three positive stops at 0°, 45° and 90° 459 

Continuous Rating Input	701W
Blade Diameter	100 mm (4")
No Load Speed (RPM)	11,000
Dimensions (L x W x H)	302x139x145mm (11-7/8"x5-1/2"x3-3/4")
Net Weight	2.8kg (6.2lbs)
Power Supply Cord	2.5m (8.2ft)



Cutter Blade, Angle Guide, Dust Bag, Set Plate, Lock Nut Wrench

## DCO181Z 6.35mm (1/4") Cordless Cut-Out Tool

High power delivered by BL motor



Collet Capacity	3 mm, 6 mm or 1/8", 1/4"
No load speed (rpm)	32,000
Max Output	600 W
Circumference of Grip Portion	210 mm (8-1/4")
Dimensions (L x W x H)	w/ BL1815N: 293x79x117 mm (11-1/2"x3-1/8"x4-5/8") w/ BL1830B / BL1850B / BL1860B: 311x79x117 mm (12-1/4"x3-1/8"x4-5/8")
Net weight	1.4 - 1.7 kg (3.1 - 3.7 lbs.)



Drywall Guide Bit, Collet Cone, Dust Collection Cover, Wrench, Battery, Charger, Z: Battery and Charger are sold separately

## RT001GM202(RM2J) / GZ04

6mm (1/4"), 8mm (3/8") Cordless Trimmer

New

Compatible with the bases used for DRT50



Collet Capacity	6, 8 mm or 1/4 - 3/8"
No Load Speed (RPM)	10,000 - 31,000
Plunge Capacity	w/ Trimmer Base: 0 - 40 mm (0 - 1-9/16") w/ Plunge Base: 0 - 35 mm (0 - 1-3/8")
Dimensions (L x W x H)	w/ BL4020 / BL4025: 126 x 89 x 245 mm (5 x 3-1/2 x 9-5/8") w/ BL4040: 141 x 89 x 261 mm (5-9/16 x 3-1/2 x 9-7/8")
Net weight	2.2 - 2.5 kg (4.9 - 5.5 lbs.)



Collet Cone, Trimmer Base Assembly, Straight Guide Assembly, Templet Guide (country-specific), Wrench, Trimmer Guide (country-specific), Dust Nozzle, Tilt Base Assembly (country-specific), Offset Base Assembly (country-specific), Plunge Base Assembly (country-specific), Battery, Charger



**DRT50Z 6mm (1/4"), 8mm (3/8") Cordless Trimmer**

Cordless for easy maneuverability and 4 different bases for added versatility

Li-ion Ah 6.0 5.0 3.0 1.5



Collet Capacity	6, 8 mm or 1/4, 3/8"
No Load Speed (RPM)	10,000 - 30,000
Plunge Capacity	w/ Trimmer Base: 0 - 40 mm (0 - 1-9/16") w/ Plunge Base: 0 - 35 mm (0 - 1-3/8")
Dimensions (L x W x H)	w/ BL1815N / BL1820B: 134 x 89 x 208 (5-1/4 x 3-1/2 x 8-1/8) w/ BL1830B / BL1850B / BL1860B: 134 x 89 x 226 mm (5-1/4 x 3-1/2 x 8-7/8")
Net weight	1.8 - 2.1 kg (3.9 - 4.6 lbs.)

18V



Collet Cone, Trimmer Base Assembly, Straight Guide Assembly, Templet Guide, Wrench x2, Trimmer Guide, Battery, Fast Charger, Z: Battery and Charger are sold separately

**RT0700C / CX2 6mm (1/4"), 8mm (3/8") Trimmer**

Aluminum housing and base for higher durability and accuracy

411



Continuous Rating Input	710W
Collet Capacity	6mm, 8mm or 1/4", 3/8"
No Load Speed (RPM)	10,000-30,000
Sound Power Level	93 dB(A)
Dimensions (L x W x H)	89x89x200mm (3-1/2"x3-1/2"x7-7/8")
Net Weight	1.8 - 2.7kg (3.9 - 6.0lbs)
Power Supply Cord	2.5m (8.2ft)



Trimmer Base Assembly, Straight Guide, Collect Cone X 2, Wrench X 2, Template Guide X 1

**N3701 6mm (1/4") Trimmer**

Transparent acrylic base for clear view of trimming area and sight line

51

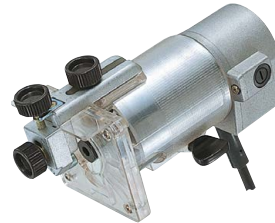

Continuous Rating Input	440W
Collet Capacity	6mm or 1/4"
No Load Speed (RPM)	30,000
Overall Height	181 mm (7-1/8")
Net Weight	1.6kg (3.4lbs)
Power Supply Cord	2.5m (8.2ft)

Trimmer Guide Assembly, Straight Guide Assembly, Template Guide, Straight Bit (Carbide-Tipped), Wrench (2pcs.)

**3711 6mm (1/4") Trimmer**

New

6 mm (1/4") 530 W Fixed Base Trimmer



Continuous rating Input	530W
Collet Capacity	6 mm or 1/4"
No Load Speed (RPM)	32,000
Plunge Capacity	0 - 42 mm (0 - 1-5/8")
Dimensions (L x W x H)	82 x 90 x 211 mm (3-1/4 x 3-1/2 x 8-5/16")
Net weight	1.5 kg (3.3 lbs.)
Power supply cord	2.5 m (8.2 ft)



Collet Cone, Trimmer Guide, Straight Guide Assembly, Templet Guide, Straight Bit, Chip Deflector, Wrench

**RP0900 8mm (3/8") Router (Plunge type)**

High durability and good design router

106



Straight Guide, Collet Cone, Wrenches

Continuous Rating Input	900W
Capacity	Collet: 6mm, 8mm or 1/4", 3/8"
No Load Speed (RPM)	27,000
Sound Power Level	100 dB(A)
Dimensions (L x W x H)	110 x 256 x 217mm (10-3/32"x4-5/16"x8-17/32")
Net Weight	2.7kg (6.0lbs)
Power Supply Cord	2.5m (8.2ft)

**RP1800 12mm (1/2") Router**

Precision and Power

203



Continuous rating input	1,850W
Collet Capacity	12 mm or 1/2"
Plunge Capacity	0 - 70 mm (0 - 2-3/4")
Base dia.	170 mm (6-11/16")
No Load Speed (RPM)	22,000
Sound Power Level	97 dB(A)
Dimensions (L x W x H)	155x294x312 mm (6-1/8"x11-5/8"x12-1/4")
Net weight	6 kg (13.2 lbs.)
Power supply cord	4.0 m (13.1 ft.)



Straight Guide, Collet Cone, Wrench, Screw M6x135

**RP1801 12mm (1/2") Router (Plunge type)**

Powerful motor delivers smooth routing

203



Straight Guide, Guide Holder, Template Guide, Wrench, Collet Sleeve X 2

Continuous Rating Input	1,650W
Collet Capacity	12mm or 1/2"
Plunge Capacity	0 - 70 mm (0 - 2-3/4")
Base Diameter	170 mm (6-11/16")
No Load Speed (RPM)	22,000
Sound Power Level	97 dB(A)
Dimensions (L x W x H)	155x294x312mm (6-1/8"x11-5/8"x12-1/4")
Net Weight	6.0kg (13.2lbs)
Power Supply Cord	4.0 m (13.1ft)

## RP2300FC 12mm (1/2") Router

Precision and Power

203



Continuous rating input	2,300W
Collet Capacity	12 mm or 1/2"
Plunge Capacity	0 - 70 mm (0 - 2-3/4")
No Load Speed (RPM)	9,000 - 22,000
Sound Power Level	98 dB(A)
Dimensions (L x W x H)	155x294x312 mm (6-1/8"x11-5/8"x12-1/4")
Net weight	6.1 kg (13.5 lbs.)
Power supply cord	4.0 m (13.1 ft.)



Straight Guide, Collet Cone, Wrench, Screw M6x135

## 3600H 12mm (1/2") Router

Powerful 1,500W motor delivers 24,000rpm for smooth, clean routing

153



Continuous Rating Input	1,500W
Collet Capacity	12mm or 1/2"
Base Diameter	160 mm (6-1/4")
No Load Speed (RPM)	24,000
Overall Height	210 mm (8-1/4")
Net Weight	4.3kg (9.5lbs)
Power Supply Cord	5.0m (16.4ft)



Trimmer Guide Assembly, Straight Guide Assembly, Template Guide, Collet Sleeve (6mm or 1/4"), Collet Sleeve (8mm or 3/8"), Wrench, Straight Bit (Carbide-Tipped)

## 3601B 12mm (1/2") Router

Fine power-to-weight ratio in this well-balanced router

153



Continuous Rating Input	930W
Collet Capacity	12mm or 1/2"
No Load Speed (RPM)	23,000
Overall Height	190 mm (7-1/2")
Net Weight	3.6kg (7.9lbs)
Power Supply Cord	5.0m (16.4ft)



Trimmer Guide Assembly, Straight Guide Assembly, Template Guide, Collet Sleeve (6mm or 1/4"), Collet Sleeve (8mm or 3/8"), Wrench (2pcs), Straight Bit (Carbide-Tipped)

## 4403 6mm (1/4") Sash Router

Mills and drills aluminum for sashes

411



Continuous Rating Input	530W
Collet Capacity	6 mm or 1/4"
Max Width of Work	123 mm (4-7/8")
Max Width of Work (45°)	77 mm (3")
Max Height of Work	185 mm (7-1/4")
Transverse Travel of Table (Bed)	113 mm (4-1/2")
Longitudinal Travel of Table (Bed)	73 mm (2-7/8")
No Load Speed (RPM)	30,000
Dimensions (L x W x H)	327x350x355 mm (12-7/8"x13-13/16"x14")
Net Weight	16 kg (35.3 lbs)
Power Supply Cord	2.5 m (8.2 ft)



Sash Router Bit (Drill Point), Angle Gauge, Wrench X2, Oil Supply, Collet Cone (6mm or 1/4")

## PRODUCTS



## SANDING &amp; POLISHER

## DSL801Z 225mm (8-7/8") Cordless Drywall Sander

New

Variable Speed Drywall Sander

Li-ion Ah 6.0 5.0 3.0 1.5



Pad diameter	210 mm (8-1/4")
Abrasive Disc Size	225 mm (8-7/8")
No Load Speed (RPM)	1,000 - 1,800
Dimensions (L x W x H)	1,120-1,540 x 278 x 273mm (44-60-1/2 x 11 x 10-3/4")
Net weight	4.6 - 5.8 kg (10.1 - 12.8 lbs.)

18V



Abrasive Disc, Hex Wrench, Tool Bag, Wireless Unit (country-specific), Wireless Unit Adapter (country-specific), Battery, Charger, Z: Battery and Charger are sold separately

## DSL800Z 225mm (8-7/8") Cordless Drywall Sander

Constant speed control for smooth finish

Li-ion Ah 6.0 5.0 3.0 1.5



Pad diameter	210 mm (8-1/4")
Abrasive Disc Size	225 mm (8-7/8")
No Load Speed (RPM)	1,000 - 1,800
Max Output	260 W
Sound Pressure Level	75 dB(A)
Dimensions (L x W x H)	1,100-1,520x259x273mm (43-1/4"-59-3/4" x 10-1/4"x10-3/4")
Net weight	4.5 - 5.7 kg (10.0 - 12.6 lbs.)

18V



Abrasive Disc, Hex Wrench, Tool Bag, Wireless Unit (country-specific), Wireless Unit Adapter (country-specific), Battery, Charger, Z: Battery and Charger are sold separately



# High dust collection rate 95%



Photo: DSL801

Continuous runtime  
**35 min**  
Battery: \*BL1850B

**AWS** Auto-start Wireless System



The wireless activation function enables clean and comfortable operation. By connecting a supported tool to the cleaner, you can run the cleaner automatically along with the switch operation of the tool.

Wireless unit is compatible with all supported tools



Connecting to vacuum hose

**BL MOTOR**

Placing the Brushless motor on head



**Constant Speed Control**  
for smooth finish

**Variable speed control dial**  
**No Load Speed: 1,000-1,800min<sup>-1</sup>**  
allows operator to adjust sanding speed depending on material or application.

**Length adjustable telescopic pipe**  
Overall length

1,540mm | 1,120mm



## DPO600RTE / Z 150mm (6") Cordless Random Orbit Polisher

Random Orbit Polisher

Li-ion Ah 6.0 5.0 3.0 1.5



DPO600RTE / Z



Pad Size	150 mm (6")
Orbits Per Minute (OPM)	0 - 6,800
Strokes Per Minute (SPM)	0 - 13,600
No Load Speed (RPM)	0 - 780
Sound Pressure Level	83 dB(A)
Sound Power Level	94 dB(A)
Orbit Diameter	5.5 mm (7/32")
Dimensions (L x W x H)	530x148x126 mm (20-7/8"x5-7/8"x5")
Net Weight	3.1 - 3.6 kg (6.9 - 7.9 lbs.)

18V



LXT BL XPT

Side Grip, Hex Wrench, Z: Battery and Charger are sold separately

## PO6000C 150mm (6") Random Orbit Polisher

Random Orbit Polisher

318 W



Continuous Rating Input	900W
Pad Size	150 mm (6")
Orbits Per Minute (OPM)	0 - 6,800
Strokes Per Minute (SPM)	0 - 13,600
No Load Speed (RPM)	0 - 780
Sound Power Level	94 dB(A)
Orbit Diameter	5.5 mm (7/32")
Dimensions (L x W x H)	451x148x126 mm (17-3/4"x5-7/8"x5")
Net Weight	2.8 - 3.0 kg (6.2 - 6.5 lbs)
Power Supply Cord	4.0 m (13.1 ft)



2

Hex Wrench

## BO6050J Random Orbit Sander

Random orbit sander with soft start

326 W



Continuous Rating Input	750W
Pad Diameter	150mm (6")
Abrasive Disc Size	150 mm (6")
Orbits Per Minute (OPM)	1,600 - 6,800
Sanding Strokes Per Minute (SPM)	3,200 - 13,600
Pad Speed in Roto-orbit Mode (rpm)	140 - 600
Orbit Diameter	5.5 mm (7/32")
Dimensions (L x W x H)	330x155x145mm (13"x6-1/8"x5-3/4")
Net Weight	2.6kg (5.7lbs)
Power Supply Cord	2.5m (8.2ft)



1

Abrasive disc, Dust nozzle, Side grip, Pad protector

## DBO180Z Cordless Random Orbit Sander

Excellent performance with high orbital speed

Li-ion Ah 6.0 5.0 3.0 1.5



Pad diameter	123 mm (4-7/8")
Abrasive Disc Size	125 mm (5")
Orbits Per Minute (OPM)	7,000/9,500/11,000
Dimensions (L x W x H)	175x123x153 mm (6-7/8"x4-7/8"x6")
Net weight	1.4 - 1.7 kg (3.0 - 3.7 lbs)

18V



3

Dust Bag, Z: Battery and Charger are sold separately

**BO5031** Random Orbit Sander

Powerful motor and high durability

419



Continuous Rating Input	300W
Pad Diameter	123mm (4-7/8")
Abrasive Disc Size	125 mm (5")
Orbits Per Minute (OPM)	4,000-12,000
Dimensions (L x W x H)	153x123x153mm (6"x4-7/8"x6")
Net Weight	1.3kg (3.0lbs)
Power Supply Cord	2.0m (6.6ft)



Abrasive Disc, Dust Bag Or Dust Box

**PV001GM101(RMX) / GZ** Cordless Polisher

New

40Vmax XGT BL Brushless Cordless 180 mm (7") Polisher

Li-ion Ah 8.0 | 5.0 | 4.0 | 2.5 | 2.0



Capacity	Pad: 180mm
No Load Speed (RPM)	0 - 2,200
Dimensions (L x W x H)	w/ BL4050F: 547 x 198 x 196 mm (21-1/2 x 7-3/4 x 7-3/4")
Net weight	3.1 - 3.8 kg (6.8 - 8.4 lbs.)



Loop Handle / Side Handle, Hex Wrench, Battery, Charger, Z: Battery and Charger are sold separately

**DPV300RTJ / Z** Cordless Sander Polisher

18V LXT BL Cordless Sander Polisher

Li-ion Ah 6.0 | 5.0 | 3.0 | 1.5



Capacity	Polisher: 80 mm (3-1/8") Sander: 50 mm (2")
No Load Speed (RPM)	Polisher: 0 - 2,800 Sander: 0 - 9,500
Dimensions (L x W x H)	w/ BL1830B / BL1850B / BL1860B: 160 x 79 x 256 mm (6-5/16 x 3-1/8 x 10-1/8")
Net weight	1.3 - 1.6 kg (2.9 - 3.5 lbs.)



Side Grip, Pad, Adapter, Wool Pad, Sponge Pad, Z: Battery and Charger are sold separately

**PV301DSAE / DZ** Cordless Sander Polisher

12Vmax CXT BL Cordless Sander Polisher

Li-ion Ah 4.0 | 2.0 | 1.5



Capacity	Polisher: 80 mm (3-1/8") Sander: 50 mm (2")
No Load Speed (RPM)	Polisher: 0 - 2,800 Sander: 0 - 9,500
Dimensions (L x W x H)	w/ BL1016/BL1021B: 137 x 67 x 201 mm (5-3/8 x 2-5/8 x 7-7/8")
Net weight	1.1 - 1.2 kg (2.4 - 2.6 lbs.)



Side Grip, Pad, Adapter, Wool Pad, Sponge Pad, DZ: Battery and Charger are sold separately

**Cord-free Polishing**

Photo: PB002G



No load speed by dial  
**600 - 2,200**min<sup>-1</sup>

Reduction of damage to Car body  
Elastomer bumpers are positioned at the portions most likely to hit car body.



Variable speed control by dial  
Max rotation speed can be selected to suit application.

Easy-to-grip head shape  
enables user to easily press the pad to the car body in applications such as scratch removal with polishing compound.

3-Position loop handle

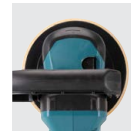

**9237C** 180mm (7") Polisher

Elastomer bumper on gear housing

303



Continuous Rating Input	1,200W
Capacity	Wool Pad: 180mm (7") Wool Bonnet: 180mm (7")
No Load Speed (RPM)	0 - 3,200
Sound Power Level	94 dB(A)
Dimensions (L x W x H)	431x198x187mm (17"x7-3/4"x7-3/8")
Net Weight	3.2 - 3.4kg (7 - 7.5 lbs)
Power Supply Cord	2.5 m (8.2 ft)



Loop Handle Or Side Grip, Accessory Set



**GV6010 150mm (6") Disc Sander**

Powerful 440W motor

64



Continuous Rating Input	440W
Abrasive Disc Size	150 mm (6")
Capacity	Pad: 120mm (4-3/4")
No Load Speed (RPM)	4,500
Dimensions (L x W x H)	200x74x181mm
Net Weight	1.2kg (2.6lbs)
Power Supply Cord	2.5m (8.2ft)



Abrasive Disc, Plastic Pad, Side Grip, Hex Socket Head Bolt, Washer, Hex Wrench

**9218SB 180mm (7") Disc Sander**

Powerful 570W motor in well-balanced body for fast and steady sanding

100



Continuous Rating Input	570W
Wire Cup Brush	110mm (4-3/8")
Abrasive Disc Size	180 mm (7")
No Load Speed (RPM)	4,500
Overall Length	225 mm (8-7/8")
Net Weight	2.3kg (5.1 lbs)
Power Supply Cord	2.5m (8.2ft)



Abrasive Disc, Rubber Pad, Lock Nut Wrench, Wrench, Side Grip

**PV7000C 180mm (7") Polisher**

Quick-Flip speed change for compounding and polishing

303



Continuous Rating Input	900W
Capacity	Pad: 180mm (7") Wool Bonnet: 180mm (7")
No Load Speed (RPM)	600 - 2,100
Overall Length	210 mm (8-1/4")
Net Weight	2.1 kg (4.6 lbs)
Power Supply Cord	2.5 m (8.2 ft)



Side Handle, Pad, Wrench

**DBO380RTJ / Z Cordless Finishing Sander**

**New**

High work efficiency similar to that of BO3710

Li-ion Ah 6.0 | 5.0 | 3.0 | 1.5



Pad Size	92 x 185 (3-5/8 x 7-1/4)
Abrasive Paper Size	93 x 228 (3-5/8 x 9)
Sanding Strokes (SPM)	8,000/ 16,000/ 24,000
Orbits Per Minute (OPM)	4,000/ 8,000/ 12,000
Dimensions (L x W x H)	w/ BL1830B / BL1850B / BL1860B: 332 x 92 x 169 mm (13-1/4 x 3-5/8 x 6-5/8")
Net weight	2.2 kg (4.9 lbs.)



Abrasive Paper, Dust Bag / Dust Box, Punch Plate, Z: Battery and Charger are sold separately

**Stress-free sanding without cord**

Both motor and battery are located above the sanding face to suppress fluttering of the base, enabling to provide an evenly finished surface.



**Battery protector**  
Prevents damage to the battery and work material



**Detachable front grip**  
Detachable without tools and can be ground close-to-wall

**Easy-to-operate paper clamp**  
ensures easy installation/removal of paper with rolled clamer's edges.

**Independently replaceable Pad**  
it can be independently replaced as it fastened to machine's base with screws. And surely saves your repairing cost.



Photo: DBO380

**Speed control by push button**  
3-stage electric speed control: 4,000/ 8,000/ 12,000min<sup>-1</sup>



**Available with Dust bag or Dust box**  
Also connectable to Makita vacuum cleaners



**Rigid aluminum foot with sponge sleeve**  
provides high durability and effective vibration-absorbing performance.

**Continuous run time**

we sanded SPF plate with a pressing load of 3kgf at high speed mode

about **50 min** Battery: BL1860B (on a full battery charge)



**9035H Finishing Sander**

Ergonomic tool body for controlled operation

419



Continuous Rating Input	180W
Pad Size	93 x 185 mm (3-5/8" x 7-1/4")
Abrasive Paper Size	93 x 228 mm (3-5/8" x 9")
Orbits Per Minute (OPM)	11,000
Dimensions (L x W x H)	236x93x146mm (9-1/4"x3-5/8"x5-3/4")
Net Weight	1.5kg (3.3lbs)
Power Supply Cord	2.5m (8.2ft)



Abrasive Paper X 6

**BO3710 Finishing Sander**

11,000 OPM for increased efficiency and smooth finish sanding

64



Continuous Rating Input	190W
Pad Size	93 x 185 mm (3-5/8" x 7-1/4")
Abrasive Paper Size	93 x 228 mm (3-5/8" x 9")
Orbits Per Minute (OPM)	11,000
Strokes Per Minute (SPM)	22,000
Orbit Diameter	2.0 mm (1/16")
Dimensions (L x W x H)	253x92x154mm (10"x3-5/8"x6-1/16")
Net Weight	1.6 kg (3.5 lbs)
Power Supply Cord	2.0 m (6.6 ft)



Abrasive Paper, Punch Plate, Dust Bag or Dust Box



**BO4900V** 115mm x 229mm (4-1/2" x 9") Finishing Sander

Through-the-Pad Dust Collection System

419



Continuous rating input	330W
Pad Size	115 x 229 mm (4-1/2" x 9")
Abrasive Paper Size	115 x 232 mm (4-1/2" x 9-1/8")
Orbits Per Minute (OPM)	4,000 - 10,000
Overall Length	289 mm (11-3/8")
Net weight	2.9 kg (6.4 lbs.)
Power supply cord	2.5 m (8.2 ft)



Abrasive Paper, Paper Dust Bag / Dust Bag, Paper Dust Bag Holder

**BO4510H** 110mm x 100mm (4-5/16" x 3-15/16") Finishing Sander

Ergonomic tool body for controlled operation

419



Continuous Rating Input	170W
Pad Size	110 x 100 mm (4-5/16" x 3-15/16")
Abrasive Paper Size	114 x 140 mm (4-1/2" x 5-1/2")
Orbits Per Minute (OPM)	12,000
Dimensions (L x W x H)	116 x 110 x 129 mm (4-9/16" x 4-3/8" x 5-1/8")
Net Weight	1.1 kg (2.4 lbs)
Power Supply Cord	2.5m (8.2ft)



Abrasive Paper X 6

**DBO481RTJ / Z** Cordless Finishing Sander

New

18V LXT Li-Ion 1/4 Sheet Finishing Sander

Li-ion Ah 6.0 5.0 3.0 1.5



Pad Size	112 x 102 mm (4-3/8" x 4")
Abrasive Paper Size	Clamp type: 140 x 114 mm (5-1/2" x 4-1/2")
Orbits Per Minute (OPM)	High: 4,000, Low: 11,000
Dimensions (L x W x H)	w/ BL1830B / BL1850B / BL1860B: 171 x 112 x 151 mm (6-3/4" x 4-3/8" x 5-15/16")
Net weight	1.4 - 1.7 kg (3.1 - 3.8 lbs.)



18V

Abrasive Paper, Dust Bag / Dust Box, Punch Plate, Z: Battery and Charger are sold separately

**BO4556** 112mm x 102mm (4-3/8" x 4") Finishing Sander

Powerful 200W motor, low vibration, low noise

419



Continuous Rating Input	200W
Pad Size	112 x 102 mm (4-3/8" x 4")
Abrasive Paper Size	114 x 140 mm (4-1/2" x 5-1/2")
Orbits Per Minute (OPM)	14,000
Dimensions (L x W x H)	131 x 112 x 141 mm (5-1/8" x 4-3/8" x 5-9/16")
Net Weight	1.1 kg (2.5 lbs)
Power Supply Cord	2.0m (6.6ft)



Abrasive Paper, Dust Bag, Punch Plate

**DBS180Z** 9mm Cordless Belt Sander

Large 533 mm (21") belt length for faster work

Li-ion Ah 6.0 5.0 3.0 1.5



Belt Width	6/9/13 mm (1/4/3/8/1/2")
Belt Length	533 mm (21")
Belt Speed	600 - 1,700 m/min
Max Output	530 W
Dimensions (L x W x H)	w/ BL1830B / BL1850B / BL1860B: 500 x 96 x 116 mm (19-3/4" x 3-3/4" x 4-9/16") w/ Side Grip & BL1830B / BL1850B / BL1860B: 500 x 245 x 126 mm (19-3/4" x 9-5/8" x 5")
Net weight	1.8 - 2.1 kg (4.0 - 4.6 lbs.)



18V



Sanding Belt, Grip, Grip Base, Battery, Charger, Z: Battery and Charger are sold separately

**9031** 30mm x 533mm (1-3/16" x 21") Belt Sander

Optimum for use in close quarters or on irregular shapes

411



Continuous Rating Input	550W
Belt Size	30 x 533mm (1-1/8" x 21")
Belt Speed	200 - 1,000m / min. (656 - 3,280ft / min)
Overall Length	380 mm (15")
Net Weight	2.1 kg (4.6 lbs)
Power Supply Cord	2.5m (8.2ft)



Abrasive Belts set, Grip

**9924DB** 76mm x 610mm (3" x 24") Belt Sander

Sufficient power, proven reliability and well balanced design

100



Continuous Rating Input	850W
Belt Size	76 x 610, 620mm (3" x 24, 24-3/8")
Belt Speed	400m / min. (1,300ft / min)
Overall Length	355 mm (14")
Net Weight	4.8kg (10.6 lbs)
Power Supply Cord	5.0m (16.4ft)



Abrasive Belt, Carbon Plate, Dust Bag Assembly

**9401** 100mm x 610mm (4" x 24") Belt Sander

Perfect for flush-along-side sanding as well as open areas

153



Continuous Rating Input	940W
Belt Size	100 x 610 mm (4" x 24")
Belt Speed	350 m/min (1,150 ft/min)
Overall Length	374 mm (14-3/4")
Net Weight	7.2 kg (15.9 lbs)
Power Supply Cord	5.0 m (16.4 ft)



Step, Dust Bag, Abrasive Belt

PRODUCTS

# DUST EXTRACTION

## UB001GM201(RMX) / GZ Cordless Blower

Powerful blowing force (Max 17N)

Li-ion Ah 8.0 5.0 4.0 2.5 2.0



Max Air Volume	15.8 m <sup>3</sup> /min (554 CFM)
Max Air Velocity	62 m/s (140 MPH)
No Load Speed (RPM)	0-23,000
Dimensions (L x W x H)	850-950 x 167 x 297 mm (33-1/2-37-1/2 x 6-9/16 x 11-3/4")
Net weight	3.1-3.9 kg (6.8-8.6 lbs.)

40Vmax



Shoulder Belt, End Nozzle, Flat Nozzle, Extension Nozzle (country-specific), Adapter Pipe (country-specific), Battery, Charger, Z: Battery and Charger are sold separately

## UB002CZ01 Battery Powered Backpack Blower

New

BL Brushless Battery Powered Variable Speed Blower



Max Air Volume	w/ End nozzle: 0-19.0 m <sup>3</sup> /min w/ Flat nozzle: 0-17.9 m <sup>3</sup> /min
Max Air Velocity	w/ End nozzle: 0-71.7 m/s w/ Flat nozzle: 0-76.0 m/s
Blowing Force	0-22.0 N
No load speed (RPM)	0-22,000
Continuous run time on a full battery charge	78 min
Sound power level	95.5 dB(A)
Dimensions (L x W x H)	w/o Nozzle: 267 x 565 x 715 mm (10-1/2 x 22-1/4 x 28-1/8") w/ Nozzle: 1.368 x 694 x 715 mm (54 x 27-1/4 x 28-1/8")
Net Weight	15.9-16.1 kg (35.1-35.4 lbs.)



Adapter Pipe, Flat Nozzle, Extension Nozzle

## UB001CZ Battery Powered Blower

Powerful blowing force (Max 20N)



Max Air Volume	Cruise Control Mode: 0-15.0 m <sup>3</sup> /min Boost Mode: 17.6 m <sup>3</sup> /min
Max Air Velocity	Cruise Control Mode: 0-60 m/s Boost Mode: 70
Avg. Air Velocity	Cruise Control Mode: 0-50 m/s Boost Mode: 58
Blowing Force	Cruise Control Mode: 0-15.0 Boost Mode: 20.0
No Load Speed (RPM)	Cruise Control Mode: 0-21,000 Boost Mode: 24,000
Dimensions (L x W x H)	960-1,060 x 295 x 180 mm
Net weight	2.6-2.9 kg (5.7-6.5 lbs.)



Shoulder Belt, End Nozzle, Flat Nozzle (country-specific), Extension Nozzle (country-specific), Adapter Pipe (country-specific)

## DUB363ZV / PG2V Cordless Blower

Able to use both in Blower and Vacuuming applications

Li-ion Ah 6.0 5.0 3.0 1.5



Max Air Volume	13.4 m <sup>3</sup> /min (473 CFM)
Max Air Velocity	65 m/s
No Load Speed (RPM)	0-7,850
Dimensions (L x W x H)	w/ 3-Stage Telescopic Long Nozzle: 737/786/836 x 200 x 415 mm (7-7/16/31") 33"x7-7/8"x16-3/8")
Net weight	4.3-6.6 kg (9.4-14.6 lbs.)



Vacuum kit, Flat Nozzle, End Nozzle, Pipe, Shoulder Belt, Hex Wrench, Battery, Charger, Z: Battery and Charger are sold separately

## DUB362Z Cordless Blower

Brushless Cordless Variable 6-Speed Blower

Li-ion Ah 6.0 5.0 3.0 1.5



Capacity (Ah)	5.0 / 6.0
Energy Capacity (Wh)	90x2 / 108x2
Max Air Volume	13.4 m <sup>3</sup> /min (473 CFM)
Max Air Velocity	54 m/s (120 MPH)
No Load Speed (RPM)	11,400 - 21,500
Sound Power Level	93.5 dB(A)
Dimensions (L x W x H)	830/880/930 x 205 x 295 mm (32-3/4/34-3/4/36-5/8" x 8-1/8"x11-5/8")
Net weight	3.5 kg (7.7 lbs)



Fast charger, Battery cartridge, Nozzle, Shoulder belt, Z: Battery and Charger are sold separately

## DUB361Z Cordless Blower

Cordless blower powered by two 18V Li-ion batteries in series

Li-ion Ah 6.0 5.0 3.0 1.5



Max Air Volume	High: 4.4 m <sup>3</sup> /min (155 CFM) Low: 2.6 m <sup>3</sup> /min (92 CFM)
Max Air Velocity	High: 93 m/s (208 MPH) Low: 57 m/s (128 MPH)
No Load Speed (RPM)	High: 17,000 Low: 10,000
Sound Power Level	94.7 dB(A)
Dimensions (L x W x H)	905 x 141 x 194 mm (35-5/8" x 5-5/8" x 7-5/8")
Net weight	2.6 kg (5.9 lbs)



Nozzle, Shoulder Belt, Z: Battery and Charger are sold separately

## DUB184Z Cordless Blower

18V LXT BL Brushless Cordless Variable Speed Blower

Li-ion Ah 6.0 | 5.0 | 3.0 | 1.5



Max Air Volume	13.0 m <sup>3</sup> /min (459 CFM)
Max Air Velocity	52.1 m/s (116 MPH)
No Load Speed (RPM)	0 - 18,000
Continuous Use (min.)	w/ BL1860B: 12, w/ BL1850B: 10
Sound Pressure Level	86.6 dB(A)
Sound Power Level	93.5 dB(A)
Dimensions (L x W x H)	w/ BL1830B / BL1850B / BL1860B: 825x160x285mm (32-1/2"x 6-5/16"x11-1/4")
Net weight	2.5 - 3.0 kg (5.4 - 6.7 lbs.)

18V



Shoulder Belt, Nozzle, Battery, Charger, Hex Wrench, Z: Battery and Charger are sold separately



## AS001GZ02 Cordless Dust Blower

New

Achieves higher blowing force

Li-ion Ah 8.0 | 5.0 | 4.0 | 2.5 | 2.0



Max blowing force	Mode: 4/3/2/1: 2.8/2.3/ 1.7/1.1 N
Max air volume	Mode: 4/3/2/1: 1.1/1.0/ 0.8/0.6 m <sup>3</sup> /min
Max sealed suction	10.3 kPa
Continuous Use (min.)	Mode: 4/3/2/1: 13/17/ 25/50
Sound Pressure Level	79 dB(A)
Vibration Emission	2.5 m/s <sup>2</sup> or less
Dimensions (L x W x H)	w/ BL4020 / BL4025: 180 x 94 x 248 mm (7-1/8 x 3-11/16 x 9-3/4")
Net weight	1.5 - 2.3 kg (3.3 - 5.1 lbs.)

40Vmax



3

Nozzle 3, Nozzle 7, Nozzle 13, Pinch valve nozzle, Wide range nozzle, Battery, Charge, Country-specific: Flexible nozzle complete, Air vent hose complete, Rubber attachment 20-30, Rubber attachment, Filter C complete, Belt clip, Z: Battery and Charger are sold separately

Max air velocity

200  
m/s

[with Nozzle 7 / mode: 4]

Max air volume

1.1  
m<sup>3</sup>/min

[without Nozzle / mode: 4]

## A wide range of applications

Can be used for a wide range of applications by replacing the tip nozzle

XGT  
40Vmax  
LI-IONOne-touch  
nozzle  
replacementHanging  
hole4 stage air  
volumeVariable  
speed control  
by trigger

Photo: AS001G

## DUB186Z Cordless Blower

18V LXT Cordless Variable 3-Speed Blower

Li-ion Ah 6.0 | 5.0 | 3.0 | 1.5



Max Air Volume	3.2 m <sup>3</sup> /min
Max Air Velocity	68 m/s
No Load Speed (RPM)	0 - 18,000
Blowing Force	2.5 N
Sound Power Level	92.4 dB(A)
Dimensions (L x W x H)	w/ BL1815N: 859x156x195 mm (33-3/4"x6-1/8"x7-5/8") w/ BL1830B / BL1850B / BL1860B: 861x156x210 mm (34"x6-1/8"x8-1/4")
Net weight	1.6 - 2.1 kg (3.5 - 4.6 lbs.)

18V



Garden Nozzle, Battery, Charger, Z: Battery and Charger are sold separately

## UB101DZ Cordless Blower

12Vmax CXT Cordless Variable 3-Speed Blower

Li-ion Ah 4.0 | 2.0 | 1.5



Max Air Volume	2.6 m <sup>3</sup> /min
Max Air Velocity	56 m/s
Max Sealed Suction	N/A kPa
No Load Speed (RPM)	0 - 15,800
Blowing Force	1.6 N
Run Time (min)	w/ BL1016, High / Mid / Low: 7 / 20 / 45
Dimensions (L x W x H)	w/ BL1016/BL1021B: 849 x 155 x 184 mm (33-1/2 x 6-1/8 x 7-1/4") w/ BL1041B: 852 x 155 x 202 mm (33-1/2 x 6-1/8 x 8")
Net weight	1.4 - 1.9 kg (3.1 - 4.2 lbs.)

12Vmax



Garden Nozzle, Flexible Hose (country-specific), Battery, Charger, DZ: Battery and Charger are sold separately



**DUB185Z Cordless Blower**

18V LXT Cordless Variable 3-Speed Blower

Li-ion Ah 6.0 | 5.0 | 3.0 | 1.5



Max Air Volume	3.2 m <sup>3</sup> /min
Max Air Velocity	98 m/s
Max Sealed Suction	5.8 kPa
No Load Speed (RPM)	0 - 18,000
Blowing Force	3.1 N
Sound Power Level	94 dB(A)
Dimensions (L x W x H)	w/ BL1815N: 515x156x195 mm (20-1/4"x6-1/8"x7-5/8") w/ BL1830B / BL1850B / BL1860B: 517x156x210 mm (20-3/8"x6-1/8"x8-1/4")
Net weight	1.6 - 2.1 kg (3.5 - 4.6 lbs.)

18V 3

Nozzle, Battery, Charger, Z: Battery and Charger are sold separately

**UB100DZ Cordless Blower**

12Vmax CXT Cordless Variable 3-Speed Blower

Li-ion Ah 4.0 | 2.0 | 1.5



Max Air Volume	2.6 m <sup>3</sup> /min
Max Air Velocity	75 m/s
Max Sealed Suction	4.0 kPa
No Load Speed (RPM)	0 - 15,800
Blowing Force	1.8 N
Run Time (min)	w/ BL1016, High / Mid / Low: 8 / 20 / 45
Dimensions (L x W x H)	w/ BL1016/BL1021B: 505 x 155 x 184 mm (19-7/8" x 6-1/8" x 7-1/4") w/ BL1041B: 508 x 155 x 202 mm (20 x 6-1/8" x 8")
Net weight	1.4 - 1.9 kg (3.1 - 4.2 lbs.)

12Vmax 1

Nozzle, Dust Bag (country-specific), Flexible Hose (country-specific), Battery, Charger, DZ: Battery and Charger are sold separately

**UB1102 Blower**

High output air volume

303



Continuous Rating Input	600W
Air Volume	4.1 m <sup>3</sup> /min
Air Pressure	5.7 kPa
No Load Speed (RPM)	16,000
Dimensions (L x W x H)	479x185x178 mm (18-7/8"x7-1/4"x7")
Net Weight	1.9 - 2.2 kg (4.3 - 4.8 lbs.)
Power Supply Cord	2.5 m (8.2 ft.)

2

Nozzle Assembly Front Cuffs 24, Poly Bag Set

**UB1103 Blower**

High output air volume

303



Continuous Rating Input	600W
Air Volume	0-4.1 m <sup>3</sup> /min
Air Pressure	0-5.7 kPa (0-580 mmH <sub>2</sub> O)
No Load Speed (RPM)	0-16,000
Dimensions (L x W x H)	479x185x178mm (18-7/8"x7-1/4"x7")
Net Weight	2.0kg (4.3lbs)
Power Supply Cord	2.5m (8.2ft)

110V 2

Nozzle Assembly Front Cuffs 24, Poly Bag Set



**VC004GLZ (Dry) Cordless Vacuum Cleaner**

**New**

40Vmax BL AWS Cordless 15L HEPA GYUPPA Vacuum Cleaner

Li-ion Ah 8.0 | 5.0 | 4.0 | 2.5 | 2.0



Capacity	Dust: 15L
Continuous Use (min.)	BL4050F x2: 220
Max Air Flow	1.8 m <sup>3</sup> /min
Max Sealed Suction	23 kPa
Suction Power	205 W
Dimensions (L x W x H)	366 x 334 x 475 mm (14-3/8" x 13-1/8" x 18-3/4")
Net weight	8.5 - 10.4 kg (18.7 - 22.9 lbs.)

40Vmax 1

Floor Nozzle, Corner Nozzle, Straight Pipe, Bent Pipe, Hose (38mm-2.5m), Plastic Dust Bag, Plastic Dust Bag x10, Cloth Filter, Tool Box, Battery, Charger, Wireless Unit, Z: Battery and Charger are sold separately

**VC003GLZ (Wet & Dry) Cordless Vacuum Cleaner**

**New**

40Vmax BL Cordless 15L Vacuum Cleaner

Li-ion Ah 8.0 | 5.0 | 4.0 | 2.5 | 2.0



Capacity	Dust/Water: 15/ 12L
Continuous Use (min.)	BL4050F x2: 220
Max Air Flow	3.2 m <sup>3</sup> /min
Max Sealed Suction	23 kPa
Suction Power	310 W
Dimensions (L x W x H)	366 x 334 x 475 mm (14-3/8" x 13-1/8" x 18-3/4")
Net weight	8.3 - 10.2 kg (18.3 - 22.5 lbs.)

40Vmax 1

Floor Nozzle, Long Sash Nozzle, Telescopic pipe assembly, Bent Pipe, Pipe, Hose, Plastic Dust Bag x10, Filter, Tool Box, Battery, Charger, Z: Battery and Charger are sold separately

**DVC150LZ (Wet & Dry) Corded and Cordless Vacuum Cleaner**

Powered by AC and Two 18V Li-Ion Batteries in Series

353

Li-ion Ah 6.0 | 5.0 | 3.0 | 1.5



Capacity	Dust/Water: 15/ 12L
Max Air Flow	AC / DC: 3.6 / 2.1 m <sup>3</sup> /min
Max Sealed Suction	AC / DC: 24 / 9 kPa
Suction Power	AC / DC: 320 / 25 - 70 W
Vibration Level	2.5 m/s <sup>2</sup> or less
Sound Pressure Level	75 dB(A)
Dimensions (L x W x H)	366x334x421 mm (14-3/8"x13-1/8"x16-1/2")
Net weight	8.9 - 9.6 kg (19.7 - 21.1 lbs.)

18V x2 1

Floor Nozzle, Corner Nozzle, Straight Pipe, Bent Pipe, Hose (38mm-2.5m), Plastic Dust Bag, Plastic Dust Bag x10, Cloth Filter, Tool Box, Connection cord (country-specific), Battery, Charger, Z: Battery and Charger are sold separately

**DVC151LZ (Dry) Corded and Cordless Vacuum Cleaner**

HEPA Filter is Used to Capture Very Fine Particles Effectively

353

Li-ion Ah 6.0 5.0 3.0 1.5



Capacity	Dust/Water: 15/N/AL
Max Air Flow	AC/DC: 3.6 / 2.1 m <sup>3</sup> /min
Max Sealed Suction	AC/DC: 24 / 9 kPa
Suction Power	AC/DC: 320 / 25 - 70 W
Vibration Level	2.5 m/s <sup>2</sup> or less
Sound Pressure Level	75 dB(A)
Dimensions (L x W x H)	366x334x421 mm (14-3/8"x13-1/8"x16-1/2")
Net weight	9.6 - 10.3 kg (21.2 - 22.6 lbs)

18V x2



Floor Nozzle, Corner Nozzle, Straight Pipe, Bent Pipe, Hose (38mm-2.5m), Plastic Dust Bag, Plastic Dust Bag x10, Powder Filter, Tool Box, Connection cord (country-specific), Battery, Charger, Z: Battery and Charger are sold separately

**DVC153LZ (Dry) Cordless Vacuum Cleaner**

HEPA Filter is used to capture very fine particles effectively

Li-ion Ah 6.0 5.0 3.0 1.5



Capacity	Dust/Water: 15/N/AL
Max Air Flow	2.1 m <sup>3</sup> /min
Max Sealed Suction	9.8 kPa
Suction Power	90 W
Vibration Level	2.5 m/s <sup>2</sup> or less
Sound Pressure Level	66 dB(A)
Dimensions (L x W x H)	366x334x421 mm (14-3/8"x13-1/8"x16-1/2")
Net weight	8.0 - 8.6 kg (17.6 - 19.0 lbs)

18V x2



Floor Nozzle, Corner Nozzle, Straight Pipe, Bent Pipe, Hose (38mm-2.5m), Hose (28mm-3.5m), Plastic Dust Bag, Plastic Dust Bag x10, Cloth Filter, Tool Box, Battery, Charger, Z: Battery and Charger are sold separately

**DVC154LZ (Dry) Cordless Vacuum Cleaner**

Auto-Start Wireless System (AWS) Connects to Power Tool with Bluetooth

Li-ion Ah 6.0 5.0 3.0 1.5



Capacity	Dust/Water: 15/N/AL
Max Air Flow	2.1 m <sup>3</sup> /min
Max Sealed Suction	9.8 kPa
Suction Power	90 W
Vibration Level	2.5 m/s <sup>2</sup> or less
Sound Pressure Level	66 dB(A)
Dimensions (L x W x H)	366x334x421 mm (14-3/8"x13-1/8"x16-1/2")
Net weight	8.0 - 8.6 kg (17.6 - 19.0 lbs)

18V x2



Floor Nozzle, Corner Nozzle, Straight Pipe, Bent Pipe, Hose (38mm-2.5m), Plastic Dust Bag, Plastic Dust Bag x10, Cloth Filter, Tool Box, Battery, Charger, Z: Battery and Charger are sold separately

**DVC155LZX2 (Wet & Dry) Cordless Vacuum Cleaner**

18V X2 (36V) LXT BL Cordless 15 L Dust Class L Vacuum Cleaner (Wet &amp; Dry)

Li-ion Ah 6.0 5.0 3.0 1.5



Capacity	Dust/Water: 15 / 12 L
Max Air Flow	2.1 m <sup>3</sup> /min
Max Sealed Suction	11 kPa
Suction Power	105 W
Dimensions (L x W x H)	366x334x421 mm (14-3/8"x13-1/8"x16-1/2")
Net weight	7.2 - 7.9 kg (16.1 - 17.4 lbs)

18V x2



Floor Nozzle, Long Sash Nozzle, Telescopic pipe assembly, Bent Pipe, Pipe, Hose, Plastic Dust Bag x10, Filter, Tool Box, Battery, Charger, Z: Battery and Charger are sold separately

**DVC860LZ (Wet & Dry) Corded and Cordless Vacuum Cleaner**

8L Large dust bag capacity enables continuous cleaning work

353

Li-ion Ah 6.0 5.0 3.0 1.5



Capacity	Dust/Water: 8 / 6 L
Continuous Use (min.)	With BL1850B x 2: 65
Max Air Flow	AC/DC: 3.6 / 2.1 m <sup>3</sup> /min
Max Sealed Suction	AC/DC: 24 / 9 kPa
Suction Power	AC/DC: 320 / 25 - 70 W
Dimensions (L x W x H)	366x334x368mm (14-3/8"x13-1/8"x14-1/2")
Net weight	8.6 kg (19.0 lbs)

18V x2



DVC860L: Floor Nozzle, Corner Nozzle, Straight Pipe, Bent Pipe, Hose (38mm-2.5m), Plastic Dust Bag, Plastic Dust Bag x10, Cloth Filter, Tool Box, Connection cord (country-specific), Z: Battery and Charger are sold separately

**DVC865LZX2 (Wet & Dry) Cordless Vacuum Cleaner**

18V X2 (36V) LXT BL Cordless 8 L Dust Class L Vacuum Cleaner (Wet &amp; Dry)

Li-ion Ah 6.0 5.0 3.0 1.5



Capacity	Dust/Water: 8/6 L
Max Air Flow	2.1 m <sup>3</sup> /min
Max Sealed Suction	11 kPa
Suction Power	105 W
Dimensions (L x W x H)	366x334x368 mm (14-3/8"x13-1/8"x14-1/2")
Net weight	7.0 - 7.7 kg (15.7 - 17.0 lbs)

18V x2



Floor Nozzle, Long Sash Nozzle, Telescopic pipe assembly, Bent Pipe, Pipe, Hose, Plastic Dust Bag x10, Filter, Tool Box, Battery, Charger, Z: Battery and Charger are sold separately

**DVC867LZX4 (Dry) Cordless Vacuum Cleaner**

18V X2 (36V) LXT BL AWS Cordless 8 L Dust Class L HEPA Vacuum Cleaner (Dry only)

Li-ion Ah 6.0 5.0 3.0 1.5



Capacity	Dust/Water: 8 / - L
Max Air Flow	2.4 m <sup>3</sup> /min
Max Sealed Suction	11 kPa
Suction Power	110 W
Dimensions (L x W x H)	366x334x368 mm (14-3/8"x13-1/8"x14-1/2")
Net weight	7.7 - 8.4 kg (17.2 - 18.5 lbs)

18V x2



Floor Nozzle, Corner Nozzle, Straight Pipe, Bent Pipe, Hose (38mm-2.5m), Plastic Dust Bag, Plastic Dust Bag x10, Cloth Filter, Tool Box, Battery, Charger, Wireless Unit, Z: Battery and Charger are sold separately

**DVC560PG2 / Z Cordless Upright Cleaner**

18V X2 (36V) LXT BL Brushless Cordless 5 L HEPA Upright Cleaner

Li-ion Ah 6.0 5.0 3.0 1.5



Capacity	Dust: 5 L
Continuous Use (min.)	w/BL1860B x2 Max / Normal / Low Noise: 30 / 60 / 120
Max Air Flow	1.9 m <sup>3</sup> /min
Max Sealed Suction	12 kPa
Suction Power	Max / Normal / Low Noise: 85 / 50 / 25 W
Cleaning Width	318 mm
Brushroll Rotation Speed	Max / Normal / Low Noise: 3,500 / 2,500 / 1,000 RPM
Dimensions (L x W x H)	326 x 318 x 1,146 mm (12-7/8 x 12-1/2 x 45")
Net weight	8.3 - 9.0 kg (18.3 - 19.8 lbs)

18V x2



Long Sash Nozzle, Round Brush, Filter Bag, Filter H, Filter Bag Set, Z: Battery and Charger are sold separately



For Cleaning VC008G



For Dust Collecting VC009G



**HEPA filter**

HEPA Filter is used as the main filter to capture very fine particles effectively.

Able to capture 99.97% of particles as small as 0.3-1 μm



**Loop**

The loop on the lower belt can be used for carrying nozzles as illustrated.



**Anti-forgetting mechanism for paper dust bag installation**

When the filter bag/dust bag is not installed in the cleaner, the front cover does not close completely.



**Carrying hook**

With a handle convenient for carrying



**Comfortable harness designed to reduce stiffness of shoulders, back and waist**

Mesh material is used for the back surfaces that touch shoulders, back and waist, reducing stuffy feeling.



	Max Air Flow
VC008G	2.4 m <sup>3</sup> /min
VC009G	1.9 m <sup>3</sup> /min

	Max Sealed Suction
VC008G	18 kPa
VC009G	18 kPa

**VC008GZ04 Cordless Backpack Vacuum Cleaner** New

40Vmax XGT BL Brushless Cordless HEPA Backpack Vacuum Cleaner

Li-ion Ah 8.0 5.0 4.0 2.5 2.0



Capacity	Paper Dust Bag: 2.0 L Cloth Dust Bag: 1.5 L
Max Air Flow	2.4 m <sup>3</sup> /min
Max Sealed Suction	18 kPa
Suction Power	w/ Hose 32-1.0 (Max): 180 W
Dimensions (L x W x H)	233 x 151 x 376 mm (9-1/8 x 5-15/16 x 14-3/4")
Net weight	4.3 - 4.7 kg (9.5 - 10.4 lbs.)

40Vmax 1

Floor Nozzle, Hose, Hose Band, Nozzle, Telescopic pipe assembly, Bent Pipe, Switching nozzle, Free Nozzle, Dust Bag, Front Cuff (country-specific), Battery, Charger, Z: Battery and Charger are sold separately

**VC009GZ Cordless Backpack Vacuum Cleaner** New

40Vmax XGT BL AWS Cordless HEPA Backpack Vacuum Cleaner

Li-ion Ah 8.0 5.0 4.0 2.5 2.0



Capacity	Paper Dust Bag: 2.0 L Cloth Dust Bag: 1.5 L
Max Air Flow	1.9 m <sup>3</sup> /min
Max Sealed Suction	18 kPa
Suction Power	w/ Hose 28-1.5, Max/High/Normal: 165 / 85 / 45
Dimensions (L x W x H)	233 x 151 x 376 mm (9-1/8 x 5-15/16 x 14-3/4")
Net weight	4.3 - 4.7 kg (9.5 - 10.4 lbs.)

40Vmax 1

Hose, Hose Band, Dust Bag, Front Cuff (country-specific), Wireless Unit, Battery, Charger, Z: Battery and Charger are sold separately

**DVC660ZX7 Cordless Backpack Vacuum Cleaner**

18V X2 (36V) LXT BL Brushless HEPA Cordless Backpack Vacuum Cleaner

Li-ion Ah 6.0 5.0 3.0 1.5



Capacity	Paper Dust Bag: 6.0 L Cloth Dust Bag: 5.5 L w/ Hose complete 32-1.0: 2.2 m <sup>3</sup> /min w/ Hose Complete 28-1.0: 2.0 m <sup>3</sup> /min
Max Air Flow	2.2 m <sup>3</sup> /min
Suction Power	Max / High / Normal w/ Hose 32-1.0: 95 / 50 / 25 W Max / High / Normal w/ Hose 28-1.0: 90 / 45 / 25 W
Vibration Level	Operation w/o Load: 2.5 m/s <sup>2</sup> or less
Dimensions (L x W x H)	297 x 174 x 523 mm (11-3/4" x 6-7/8" x 20-5/8")
Net weight	6.1 - 6.7 kg (13.4 - 14.8 lbs.)

18V x2 1

Floor Nozzle, Hose, Hose Band, Nozzle assembly, Telescopic pipe assembly, Bent Pipe, Switching nozzle, Free Nozzle, Dust Bag, Front Cuffs (22, 24), Battery, Charger, Z: Battery and Charger are sold separately

**DVC665Z Cordless Backpack Vacuum Cleaner**

18V X2 (36V) LXT BL AWS HEPA Cordless Backpack Vacuum Cleaner

Li-ion Ah 6.0 5.0 3.0 1.5



Capacity	Paper Dust Bag: 6.0 L Cloth Dust Bag: 5.5 L w/ Hose Complete 28-1.5: 1.8 m <sup>3</sup> /min
Max Air Flow	1.8 m <sup>3</sup> /min
Suction Power	High / Normal w/ Hose 28-1.5: 85 / 45 W
Vibration Level	Operation w/o Load: 2.5 m/s <sup>2</sup> or less
Dimensions (L x W x H)	297 x 174 x 523 mm (11-3/4" x 6-7/8" x 20-5/8")
Net weight	6.1 - 6.7 kg (13.5 - 14.9 lbs.)

18V x2 1

Floor Nozzle, Hose, Hose Band, Nozzle assembly, Telescopic pipe assembly, Bent Pipe, Switching nozzle, Free Nozzle, Dust Bag, Front Cuffs (22, 24), Battery, Charger, Z: Battery and Charger are sold separately



## DVC261ZX17

Cordless Backpack Vacuum Cleaner

2 L large dust bag capacity enables continuous cleaning work

Li-ion Ah 6.0 5.0 3.0 1.5



Come with paper Dust bag x10



Capacity	Paper dust bag : 2.0 L Cloth dust bag : 1.5 L
Continuous Use (min.)	w/ BL1860B (Max / High / Normal) : 40 / 75 / 140
Max Air volume	w/ Hose Complete : 28-1.5 : 1.8 m <sup>3</sup> /min w/ Hose Complete : 28-1.0 : 2.0 m <sup>3</sup> /min
Max Sealed Suction	11 kPa
Suction Power	Max / High / Normal w/ Hose 28-1.5: 85 / 45 / 25 W
Dimensions (L x W x H)	230x152x373 mm (9"x6"x14-3/4")
Net weight	3.8 - 4.5 kg (8.5 - 9.9 lbs.)

18V x2



Floor Nozzle, Flexible rubber nozzle, Telescopic pipe assembly, Hose complete 28-1.0, Bent Pipe, Hose band, Filter bag (Paper dust bag), Z: Battery and Charger are sold separately

## DVC265ZX6U

Cordless Backpack Vacuum Cleaner

Auto-start Wireless System (AWS) Connects to Power Tool with Bluetooth

Li-ion Ah 6.0 5.0 3.0 1.5



Come with paper Dust bag x10



Come with Bluetooth wireless unit



Capacity	Paper dust bag : 2.0 L Cloth dust bag : 1.5 L
Continuous Use (min.)	w/ BL1860B (High / Low) : 40 / 75
Max Air volume	w/ Hose Complete : 28-1.5 : 1.8 m <sup>3</sup> /min w/ Hose Complete : 28-1.0 : 2.0 m <sup>3</sup> /min
Max Sealed Suction	11 kPa
Suction Power	High / Normal w/ Hose 28-1.5: 85 / 45 W
Dimensions (L x W x H)	230x152x373 mm (9"x6"x14-3/4")
Net weight	3.9 - 4.5 kg (8.6 - 10.0 lbs.)

18V x2



Floor Nozzle, Flexible rubber nozzle, Telescopic pipe assembly, Hose complete 28-1.0, Bent Pipe, Hose band, Filter bag (Paper dust bag), Z: Battery and Charger are sold separately

Equipped with LiDAR sensor (2D) and Camera sensor, the cleaner can map and memorize the rooms to clean.

LiDAR sensor

+

Camera sensor



Photo: DRC300

**BL**  
MOTOR  
**HEPA**  
filter

Continuous run time (approx.)  
on a full battery charge

**240 min**

[with two BL1860B batteries]

Maximum  
cleaning area  
600m<sup>2</sup> with  
mapping  
feature



Compatible with Smartphone app  
[ Makita RoboPro DRC300 ]

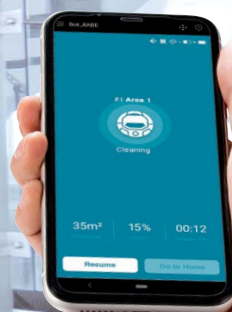

## DRC300Z Robotic Cleaner

New

18V LXT BL Brushless Robotic Cleaner w/ Mapping Function

Li-ion Ah 6.0 5.0 3.0 1.5



Continuous Use (min.)	w/ BL1860B x2: 240
Max cleaning area	w/ BL1860B x2: 600 m <sup>2</sup>
Max running speed	0.3 m/sec
Dust Box Capacity	3.0 L
Dimensions (L x W x H)	500 x 500 x 204 mm (19-3/4 x 19-3/4 x 8")
Net weight	9.6 - 10.6 kg (21.2 - 23.4 lbs.)

18V x2



Wireless remote controller (including two AAA alkaline batteries), Side Brush, Z: Battery and Charger are sold separately

## DRC200Z Robotic Cleaner

Provides easy maneuverability anywhere you need cleaning

Li-ion Ah 6.0 5.0 3.0 1.5



Continuous use (minutes)	BL1850Bx2: 200 BL1830Bx2: 120
Max. cleaning area	BL1850Bx2: 500m <sup>2</sup> BL1830Bx2: 300m <sup>2</sup>
Max. running speed	0.3 m/sec
Dust box capacity	2.5L
Dimensions (L x W x H)	460x460x180mm (18-1/8" x 18-1/8" x 7-1/8")
Net weight	7.8kg (16.1 lbs)

18V x2



Wireless remote controller (including two AAA alkaline batteries), Side brush, Boundary tape (15m roll), Z: Battery and Charger are sold separately

## DVC750LZX1 Cordless Portable Vacuum Cleaner

Compact, portable and easy-to-use

Li-ion Ah 6.0 5.0 3.0 1.5



Capacity	Dust / Water : 7.5 / 4.5 L
Continuous Use (min.)	w/ BL1850B (High) : 30 w/ BL1850B (Normal) : 60
Max Air Flow	1.3 m <sup>3</sup> /min
Max Sealed Suction	6.7 / 4.2 kPa
Suction Power	High / Low : 50 / 25 W
Dimensions (L x W x H)	418x251x278 mm (16-1/2"x9-7/8"x11")
Net weight	4.3 - 4.6 kg (9.4 - 10.1 lbs.)

18V



Hose, Floor Nozzle, Sash Nozzle, Z: Battery and Charger are sold separately

**DCL184Z Cordless Cleaner**

18V LXT Li-Ion Cordless 3-Speed Cleaner

Li-ion Ah 6.0 5.0 3.0 1.5



Capacity	Cloth / Paper Dust Bag: 500 / 330 mL
Continuous Use(min.)	Max / High / Normal: 33 / 50 / 133
Max Air Flow	Cleaning: 1.4 m <sup>3</sup> /min Blowing: 0.8 m <sup>3</sup> /min
Max Air Velocity	Blowing: 7.2 m/s
Max Sealed Suction (water column)	5.4 kPa (550 mmH <sub>2</sub> O)
Noise Level	Max / High / Normal: 68 / 65 / 58 dB(A)
Dimensions (L x W x H)	w/ BL1830B / BL1850B / BL1860B: 365x138x202 mm (14-3/8"x5-7/16"x8")
Net weight	1.8 - 2.2 kg (4.0 - 4.9 lbs.)

18V 1

Seat Nozzle, Mat Nozzle, Rubber Nozzle, Soft Brush, Blower Attachment, Dust Bag, Paper Dust Bag, Shoulder Belt, Battery, Charger, Z: Battery and Charger are sold separately

**CL121DSAX1 / DSA / DZ Cordless Cleaner**

12Vmax CXT Li-ion cordless 3-speed cleaner

Li-ion Ah 4.0 2.0 1.5



Capacity	Dust Bag: 500ml Paperbag: 330ml
Max. air flow	1.3m <sup>3</sup> / min
Continuous Use (w/ BL1041B) (min.)	Max : 27 / High : 32 / Normal : 67
Continuous Use (w/ BL1016) (min.)	Max : 10 / High : 12 / Normal : 25
Max Sealed Suction	4.4 kPa (450 mmHO)
Suction Power	Max : 30 W / High : 20 W / Normal : 5 W
Dimensions (L x W x H)	w/ BL1016/BL1021B: 345x138x202 mm (13-5/8"x5-7/16"x8")
Net weight	1.8 - 2.0 kg (4.0 - 4.4 lbs.)

12Vmax 1

Battery Charger, Battery Cartridge, Nozzle Assembly, Sash Nozzle, Sash nozzle holder, Straight pipe, Filter, DZ: Battery and Charger are sold separately

**VC3210L Vacuum Cleaner (Wet & Dry)**

Complying with dust class L

173

110V

VC3210L/B



Continuous Rating Input	1,050W
Max Peak Air Ow	2.0m <sup>3</sup> / min
Max Sealed Suction (Water Column)	22.0 kPa (2,240 mmH <sub>2</sub> O)
Tank Capacity	Dust: 32 L Water: 27 L
Dimensions (L x W x H)	552x398x685mm (21-3/4"x15-5/8"x27")
Net Weight	14.5kg (32.0lbs)
Power Supply Cord	5.0m (16.4ft)

1

Hose Complete 28-3.5 (with Front Cuffs 38), Holder 10-33, Front Cuffs 22, Front Cuffs 24, Poly Bag Set

**VC2510L Vacuum Cleaner (Wet & Dry)**

Complying with dust class L

173



Continuous Rating Input	1,050W
Max Peak Air Ow	2.0m <sup>3</sup> / min
Max Sealed Suction (Water Column)	22.0 kPa (2,240 mmH <sub>2</sub> O)
Tank Capacity	Dust: 25 L Water: 14 L
Dimensions (L x W x H)	432x416x451mm (17"x16-3/8"x17-3/4")
Net Weight	10.5kg (23.2lbs)
Power Supply Cord	5.0m (16.4ft)

1

Hose Complete 28-3.5 (with Front Cuffs 38), Holder 10-33, Front Cuffs 22, Front Cuffs 24, Plastic Dust Bag Set

**VC2000L Vacuum Cleaner (Wet & Dry)**

Wet & Dry L-class Vacuum Cleaner



Continuous rating Input	1,000W
Max. peak air flow	216 m <sup>3</sup> / h
Max. sealed suction	21kPa
Tank capacity	Dust: 20L Water: 13L
Dimensions (L x W x H)	375x 385 x 505mm (14-7/6" x 15-1/5" x 19-8/8")
Net Weight	7.5kg (16.5lbs)
Power supply cord	5.0m (16.4ft)

1

Filter Bag - Fleece, Disposal Bag - Plastic, Suction Hose, Suction Tube, Hand tube, Floor Nozzle, Nozzle Universal, Crevice Nozzle

**CL001GD115(RD/T+B) / GD126(RD/T+W) / GZ204(Z/T+B) / GZ12(Z/T+W) Cordless Cleaner**

40Vmax XGT BL Brushless Cordless 4-Speed Cleaner with LED Light

Li-ion Ah 8.0 5.0 4.0 2.5 2.0



Capacity	730 mL
Continuous Use (min.)	w/ BL4040, 1 / 2 / 3 / 4: 128 / 64 / 40 / 25
Max Air Flow	1.2 m <sup>3</sup> /min
Max Sealed Suction (water column)	21 kPa (2,100 mmH <sub>2</sub> O)
Suction Power	w/ Easy Shake Off Filter, 1 / 2 / 3 / 4: 20 / 45 / 70 / 125 W
Dimensions (L x W x H)	w/ BL4020 / BL4025: 1,066 x 113 x 152 mm w/ BL4040: 1,081 x 113 x 152 mm
Net weight	1.7 - 2.3 kg (3.5 - 5.1 lbs.)

40Vmax

Floor Nozzle, Sash Nozzle, Sash Nozzle Holder, Pipe, Filter H, Easy Shake Off Filter, Battery, Charger, Z: Battery and Charger are sold separately

**CL002GD110(RDB) / GD116(RDW) / GZ03(ZB) / GZ07(ZW) Cordless Cleaner**

New

40Vmax XGT BL Brushless Cordless 4-Speed Cleaner with LED Light

Li-ion Ah 8.0 5.0 4.0 2.5 2.0



Capacity	Dust Bag: 500 mL Paper Pack: 330 mL
Continuous Use (min.)	w/ BL4025, 1 / 2 / 3 / 4: 80 / 40 / 25 / 16
Max Air Flow	1.2 m <sup>3</sup> /min
Max Sealed Suction (water column)	21 kPa (2,100 mmH <sub>2</sub> O)
Suction Power	125 W w/ Easy Shake Off Filter, 1 / 2 / 3 / 4: 20 / 45 / 70 / 125 W
Dimensions (L x W x H)	505 x 114 x 152 mm (19-7/8 x 4-1/2 x 6")
Net weight	1.8 - 3.0 kg (4.0 - 6.6 lbs.)

40Vmax

Floor Nozzle, Sash Nozzle, Sash Nozzle Holder, Pipe, Easy Shake Off Dust Bag, Paper Dust Bag, Hand Strap, Battery, Charger, Z: Battery and Charger are sold separately

**CL003GD115(RDB) / GD114(RDW) / GZ09(ZB) / GZ14(ZW) Cordless Cleaner**

New

40Vmax XGT BL Brushless Cordless Cleaner

Li-ion Ah 8.0 5.0 4.0 2.5 2.0



Capacity	250 mL
Continuous use	w/ BL4025, Mode 1 / 2 / 3 / 4: 80 / 40 / 25 / 16 min
Max air flow	1.0 m <sup>3</sup> /min
Max sealed suction	20 kPa (2,000 mmH <sub>2</sub> O)
Suction power	w/ Easy shake off filter EX, Mode 1 / 2 / 3 / 4: 15 / 35 / 60 / 100 W
Noise level	Mode 1 / 2 / 3 / 4: 54 / 59 / 62 / 65 dB(A) w/ Pipe & Nozzle, w/ BL4040: 1,121 x 113 x 177 mm (44-1/4 x 4-7/16 x 7")
Dimensions (L x W x H)	
Net weight	1.9 - 2.5 kg (4.2 - 5.5 lbs.)

40Vmax

Floor Nozzle, Sash Nozzle, Sash Nozzle Holder, Pipe, Battery, Charger, Z: Battery and Charger are sold separately

**DCL280FZB / FZW / BX12 / FZW1** Cordless Cleaner

18V LXT BL Brushless Cordless Cleaner with LED Light

Li-ion Ah 6.0 5.0 3.0 1.5



Capacity	750 mL
Continuous Use (min.)	with BL 1830B (High): 20
Max Air Flow	1.4 m <sup>3</sup> /min
Max Sealed Suction (water column)	6.4 kPa (640 mmH <sub>2</sub> O)
Dimensions (L x W x H)	1,016 x 113 x 155 mm (40" x 4-7/16" x 6-1/8")
Net weight	1.2 - 1.6 kg (2.7 - 3.5 lbs.)

18V

Floor Nozzle, Sash Nozzle, Sash Nozzle Holder, Pipe, Filter H, Easy Shake Off Filter, Hand Strap, Battery, Charger, Z: Battery and Charger are sold separately

**DCL281FZB / FZW** Cordless Cleaner

18V LXT BL Brushless Cordless 3-Speed Cleaner with LED Light

Li-ion Ah 6.0 5.0 3.0 1.5



Capacity	750 mL
Continuous Use (min.)	w/ BL 1830B Max / High / Normal: 15 / 20 / 50
Max Air Flow	1.5 m <sup>3</sup> /min
Max Sealed Suction (water column)	8.2 kPa (820 mmH <sub>2</sub> O)
Dimensions (L x W x H)	1,016 x 113 x 154 mm (40" x 4-7/16" x 6-1/6")
Net weight	1.2 - 1.6 kg (2.7 - 3.5 lbs.)

18V

Floor Nozzle, Sash Nozzle, Sash Nozzle Holder, Pipe, Filter H, Easy Shake Off Filter, Hand Strap, Battery, Charger, Z: Battery and Charger are sold separately

**DCL282FRAW / FZW** Cordless Cleaner

18V LXT BL Brushless Cordless 3-Speed Cleaner with LED Light

Li-ion Ah 6.0 5.0 3.0 1.5



Capacity	Normal Dust Bag / Paper Filter: 500 / 330
Continuous Use (min.)	w/ BL 1830B Max / High / Normal: 15 / 20 / 50
Max Air Flow	1.5 m <sup>3</sup> /min
Max Sealed Suction (water column)	8.2 kPa (820 mmH <sub>2</sub> O)
Dimensions (L x W x H)	1,016 x 114 x 154 mm (40" x 4-1/2" x 6-1/16")
Net weight	1.3 - 1.6 kg (2.8 - 3.5 lbs.)

18V

Floor Nozzle, Sash Nozzle, Sash Nozzle Holder, Pipe, Easy Shake Off Dust Bag, Paper Dust Bag, Hand Strap, Battery, Charger, Z: Battery and Charger are sold separately

**DCL180FZW / FRGW / FZW1** Cordless Cleaner

Optimum cordless cleaner for constructors or factory

Li-ion Ah 6.0 5.0 3.0 1.5



Capacity	650 mL
Continuous Use (min.)	with BL 1830B: 20
Max Air Flow	1.4 m <sup>3</sup> /min
Max Sealed Suction (water column)	4.2 kPa (428 mmH <sub>2</sub> O)
Dimensions (L x W x H)	999 x 114 x 152 mm (39-1/4" x 4-1/2" x 6")
Net weight	1.2 kg (2.7 lbs)

18V

Nozzle Assembly, Sash Nozzle, Pipe, Filter (Factory-mounted), Pre-filter (Factory-mounted), Z: Battery and Charger are sold separately

**DCL180Z / ZB / RTB** Cordless Cleaner

Optimum cordless cleaner for constructors or factory

Li-ion Ah 6.0 5.0 3.0 1.5



Capacity	650 mL
Continuous Use (min.)	with BL 1830B: 20
Max Air Flow	1.4 m <sup>3</sup> /min
Max Sealed Suction (water column)	4.2 kPa (428 mmH <sub>2</sub> O)
Dimensions (L x W x H)	999 x 114 x 152 mm (39-1/4" x 4-1/2" x 6")
Net weight	1.2 kg (2.7 lbs)

18V

Nozzle Assembly, Sash Nozzle, Pipe, Filter (Factory-mounted), Pre-filter (Factory-mounted), Z: Battery and Charger are sold separately

**DCL181FZW / FZW1** Cordless Cleaner

18V LXT Li-Ion Cordless 2-speed Cleaner with LED Light

Li-ion Ah 6.0 5.0 3.0 1.5



Capacity	650 mL
Continuous Use (min.)	with BL 1830B (High): 20 with BL 1830B (Low): 40
Max Air Flow	1.4 m <sup>3</sup> /min
Max Sealed Suction (water column)	5.3 kPa (540 mmH <sub>2</sub> O)
Dimensions (L x W x H)	999 x 114 x 152 mm (39-1/4" x 4-1/2" x 6")
Net weight	1.2 - 1.4 kg (2.7 - 3.1 lbs.)

18V

Floor T-Nozzle28, Sash Nozzle, Sash Nozzle Holder, Pipe, Filter, Prefilter, Z: Battery and Charger are sold separately

**DCL182ZB / ZW** Cordless Cleaner

18V LXT Li-Ion Cordless 2-speed Cleaner

Li-ion Ah 6.0 5.0 3.0 1.5



Capacity	Dust Bag: 500 mL Paper Pack: 330 mL
Continuous Use (min.)	with BL 1850B (High): 33 with BL 1850B (Low): 66
Max Air Flow	1.4 m <sup>3</sup> /min
Max Sealed Suction (water column)	5.4 kPa (551 mmH <sub>2</sub> O)
Dimensions (L x W x H)	1,004 x 115 x 151 mm (39-1/2" x 4-1/2" x 5-15/16")
Net weight	1.3 kg (2.8 lbs)

18V

Nozzle Assembly, Sash Nozzle, Pipe, Filter (Factory-mounted), Pre-filter (Factory-mounted), Z: Battery and Charger are sold separately

**CL106FDSA W / FDZ** Cordless Cleaner

12Vmax CXT Li-Ion Cordless Cleaner

Li-ion Ah 4.0 2.0 1.5



Capacity	600 mL
Continuous Use (min.)	with BL 1041B: 42
Max Air Flow	1.3 m <sup>3</sup> /min
Max Sealed Suction (water column)	3.1 kPa (316 mmH <sub>2</sub> O)
Dimensions (L x W x H)	958 x 100 x 150 mm (37-3/4" x 3-15/16" x 5-7/8")
Net weight	1 - 1.1 kg (2.1 - 2.5 lbs.)

12Vmax

Floor Nozzle, Sash Nozzle, Sash Nozzle Holder, Pipe, Battery, Charger, Filter, Prefilter, DZ: Battery and Charger are sold separately



**CL107FDSA / FDZW / FDZ / FDSA** Cordless Cleaner

12Vmax CXT Li-Ion Cordless Cleaner

Li-ion Ah 4.0 2.0 1.5



Capacity	Dust Bag: 500 mL Paper Pack: 330 mL
Continuous Use (min.)	Max: 20 / High: 24 / Normal: 50
Max Air Flow	1.4 m <sup>3</sup> /min
Max Sealed Suction (water column)	5.0 kPa (510 mmH <sub>2</sub> O)
Dimensions (L x W x H)	960x112x150 mm (37-3/4"x4-3/8"x5-7/8")
Net weight	1.1 - 1.3kg (2.5 - 2.9 lbs.)

12Vmax



Floor Nozzle, Sash Nozzle, Sash Nozzle Holder, Pipe, Battery, Charger, Dust Bag, Paper Dust Bag, DZ: Battery and Charger are sold separately

**CL108FDSA / FDZ / FDZW** Cordless Cleaner

Lightweight and High Power

Li-ion Ah 4.0 2.0 1.5



Capacity	600 mL
Continuous Use (min.)	with BL1016B: Max / High / Normal: 10 / 12 / 25
Max Air Flow	1.2 m <sup>3</sup> /min
Max Sealed Suction (water column)	4.4 kPa (445mmH <sub>2</sub> O)
Dimensions (L x W x H)	956x110x150 mm (37-5/8"x4-5/16"x5-7/8")
Net weight	1.0 - 1.2kg (2.3 - 2.7 lbs.)

12Vmax



Floor Nozzle, Sash Nozzle, Sash Nozzle Holder, Pipe, Filter, Prefilter, Battery, Charger, DZ: Battery and Charger are sold separately

**CL117FDX2** Cordless Cleaner

12Vmax Li-Ion Cordless 3-Speed Cleaner with LED Light, Built-In Battery

Li-ion Ah 2.0



Dust collecting type	Capsule
Capacity	650 mL
Continuous Use (min.)	Powerful / High / Normal: 10 / 18 / 55
Max air flow	1.0 m <sup>3</sup> /min
Max sealed suction	5.0 kPa (510 mmH <sub>2</sub> O)
Suction Power	Powerful / High / Normal: 29 / 15 / 3 w/o Pipe & Nozzle:
Dimensions (L x W x H)	457 x 110 x 136 mm (18 x 4-5/16 x 5-3/8")
Net weight	1.0 kg (2.2 lbs.)

12Vmax Built-in



Floor/Carpet T-nozzle, Sash nozzle, Sash nozzle holder, Straight pipe, Charger (country-specific), Easy Shake Off Filter

**CL100DW / DZX** Cordless Cleaner

Lightweight but with strong suction power (14W)

Li-ion Ah 1.3



Capacity	600 mL
Continuous Use (min.)	12
Max Air Flow	1.2 m <sup>3</sup> /min
Max Sealed Suction (water column)	2.3kPa (235 mmH <sub>2</sub> O)
Dimensions (L x W x H)	966 x 103 x 150mm (38-1/32" x 4-1/16" x 5-7/8")
Net weight	0.88kg (1.94lbs)

10.8V



Battery Charger, Battery Cartridge, Nozzle Assembly, Sash Nozzle, Pipe, Filter (factory-mounted), Pre-filter (factory-mounted), DZ: Battery and Charger are sold separately

**CL102DW / DWX** Cordless Cleaner

20W High suction power in Turbo mode

Li-ion Ah 1.3



Capacity	Cloth dust bag: 500mL Paper dust bag: 330mL
Continuous Use (min.)	High: 13, Low: 21 (with BL 1013)
Max Air Flow	0.9m <sup>3</sup> /min
Max Sealed Suction (water column)	2.7kPa (270mm H <sub>2</sub> O)
Dimensions (L x W x H)	984 x 113 x 150mm (38-3/4"x4-7/16"x5-7/8")
Net weight	1.1kg (2.4lbs) (with BL 1013)

10.8V



Nozzle Assembly(T-nozzle), Sash Nozzle, Pipe(Extension Pipe), Sash Nozzle Holder, Cloth Dust Bag, Paper Dust Bag 5 Units, Z: Battery and Charger are sold separately

**CL104DWR / DWY / DWYX** Cordless Cleaner

20W High suction power in Turbo mode

Li-ion Ah 1.5



Capacity	Dust Bag: 500 mL Paper Pack: 330 mL
Continuous Use (min.)	Turbo / High / Low: 7 / 10 / 20
Max Air Flow	1.3 m <sup>3</sup> /min
Max Sealed Suction (water column)	3.2 kPa (326 mmH <sub>2</sub> O)
Dimensions (L x W x H)	983x113x136 mm (38-3/4"x4-7/16"x5-3/8")
Net weight	1.1 kg (2.3 lbs)

10.8V



Charger DC1001 (Charging time: 180 min. [approx]), Nozzle Assembly, Sash Nozzle, Sash Nozzle Holder, Pipe, Cloth Dust Bag, Paper Dust Bag

**CL105DWR / DWX** Cordless Cleaner

20W High suction power in Turbo mode

Li-ion Ah 1.3



Capacity	Dust Bag: 500 mL Paper Pack: 330 mL
Continuous Use (min.)	Turbo / High / Low: 7 / 10 / 20
Max Air Flow	1.3 m <sup>3</sup> /min
Max Sealed Suction (water column)	3.2 kPa (326 mmH <sub>2</sub> O)
Dimensions (L x W x H)	983x113x136 mm (38-3/4"x4-7/16"x5-3/8")
Net weight	1.1 kg (2.3 lbs)

10.8V



Charger DC1001 (Charging time: 180 min. [approx]), Nozzle Assembly, Sash Nozzle, Sash Nozzle Holder, Pipe, Cloth Dust Bag, Paper Dust Bag

**DVC350Z** Cordless Vacuum Cleaner

Limited Qty

Cordless design for high portability

Li-ion Ah 6.0 5.0 3.0 1.5



Max Air Flow	1.4 m <sup>3</sup> /min
Max Sealed Suction (water column)	6.0 kPa (612 mmH <sub>2</sub> O)
Recoverable capacity	Dust: 3.0 L (0.8 gal)
Dimensions (L x W x H)	273x195x226 mm (10-3/4"x7-5/8"x8-7/8")
Net weight	2.2 - 2.4 kg (4.8 - 5.3 lbs)

18V



Nozzle Assembly, Dust Bag Assembly, Hose Complete, Shoulder Belt, Z: Battery and Charger are sold separately

Capsule type



One touch switch



**CL001G** **40Vmax**

Easy shake off dust filter

**BL MOTOR HEPA filter**

**Max Air Flow** **Max Sealed Suction**  
**1.2m³/min** **21 kPa**

**DCL281F** **18V**

Easy shake off dust filter

**BL MOTOR HEPA filter**

**Max Air Flow** **Max Sealed Suction**  
**1.5m³/min** **8.2kPa**

**DCL181F** **18V**

Easy shake off dust filter

**BL MOTOR HEPA filter**

**Max Air Flow** **Max Sealed Suction**  
**1.4m³/min** **5.3kPa**

Paper bag type



One touch switch



**CL002G** **40Vmax**

Easy shake off dust bag

**BL MOTOR HEPA filter**

**Max Air Flow** **Max Sealed Suction**  
**1.2m³/min** **21 kPa**

**DCL282F** **18V**

Easy shake off dust bag

**BL MOTOR HEPA filter**

**Max Air Flow** **Max Sealed Suction**  
**1.5m³/min** **8.2kPa**

**DCL182** **18V**

Easy shake off dust bag

**BL MOTOR HEPA filter**

**Max Air Flow** **Max Sealed Suction**  
**1.4m³/min** **5.4kPa**

Capsule type



Trigger switch



**DCL280F** **18V**

Easy shake off dust filter

**BL MOTOR HEPA filter**

**Max Air Flow** **Max Sealed Suction**  
**1.4m³/min** **6.4kPa**

**DCL180** **18V**

Easy shake off dust filter

**BL MOTOR HEPA filter**

**Max Air Flow** **Max Sealed Suction**  
**1.4m³/min** **4.2kPa**

**CL106FD** **12Vmax**

Easy shake off dust filter



**BL MOTOR HEPA filter**

**Max Air Flow** **Max Sealed Suction**  
**1.3m³/min** **3.1 kPa**

### Dust classes in accordance with the EU standard

Since 1997, hazardous dusts have been categorized into 3 ( three ) classes, namely, Class L, Class M and Class H, which is regulated by IEC60335-2-69 ( world wide ) and by EN 60335-2-69. The vacuum cleaners suitable for each of dust class have been also defined by these regulations as follows :

Dust class	Model No.	Definition Of Dust	Major requirement	Dust permeability *4
H	VC3211H	*OEL values >0.1mg/m³ all kinds of dusts caused cancer, disease.	• Air flow sensor • Filter protection structure *1 • Structure that requires a tool for filter removal/installation *2 • Structure that protects users from exposure to dust when emptying dust bag *3	less than 0.005%
M	VC3211M, VC2211M, VC4210M, VC3012M,	*OEL values >0.1mg/m³ as well as saw dust	• Air flow sensor • Filter protection structure *1	less than 0.1%
L	VC1310L, VC2510L, VC3210L, DVC860L, DVC861L, DVC865L, DVC866L, DVC867L, DVC750L, DVC150L, DVC151L, DVC155L, DVC156L, DVC157L, VC4210L, VC2012L, VC2512L, VC3011L, VC3012L	*OEL values >1mg/m³		less than 1%

 <p><b>CL108FD</b> 12Vmax</p> <p>Max Air Flow: <b>1.2m<sup>3</sup>/min</b> Max Sealed Suction: <b>4.4kPa</b></p>	 <p><b>CL117FD</b> 2.0Ah 12Vmax Built-in Battery</p> <p>Max Air Flow: <b>1.4m<sup>3</sup>/min</b> Max Sealed Suction: <b>5.0kPa</b></p>
---	--

- Home
- Building
- Built-in Job Light
- Electronic 2-Speed
- Electronic 3-Speed
- Electronic 4-Speed



**CL107FD** 12Vmax

Max Air Flow: **1.4m<sup>3</sup>/min**  
Max Sealed Suction: **5.0kPa**

**Cyclone unit**



**One touch switch**

**CL003G** 40Vmax

Max Air Flow: **1.0m<sup>3</sup>/min**  
Max Sealed Suction: **20kPa**



**Cyclone attachment**

**Easy dust disposal**



Cyclone pre-separation system separates dust from air.

Easy disposal of the fine dust collected in dust case

The main unit of the cleaner requires much less frequent dust disposal.

**Suction Power Keep 90%\***

\* When used with DCL182 / wood dust

**HEPA filter** Apart from the above standard regulated by IEC/EN 60335-2-69, "HEPA" is widely recognized as one of famous guidelines of the filtration efficiency. According to this standard, the filter of "HEPA" should remove more than 99.75% of airborne particles of 0.3µm in diameter. Thus, it stipulates only a filtration efficiency of the filter itself, while IEC/EN60335-2-69 defines the vacuum machine suitable for each dust class (construction, mechanical strength of machine) as well as its dust permeability. In this sense, Dust Class H vacuum cleaner does not always have to be equipped with HEPA filter as long as it meets the requirements of IEC/EN60335-2-69. Another difference between HEPA testing methods and the IEC/EN60335-2-69 is the dust loading. Filter elements for dust classes M and H are to be tested with the limestone dust particles in large quantities for checking the physical strength of filter, while HEPA tests are done with very small liquid droplets.

- \* OEL : Occupation Exposure Limit  
In dirty indoor environment with high activity, such as schools, the average values of OEL are measured 0.5mg/m<sup>3</sup>. In case of "non-activity place", 0.15mg/m<sup>3</sup> in office and 0.2mg/m<sup>3</sup> in school are measured in average.
- \*1 Filters should be protected from sharp objects such as nails when they are accidentally sucked up. The solution for VC3211M/ VC3211H is a protector for the filter units.
- \*2 Filters loaded with dust should not be easily removed. The solution for VC3211H is a screw that locks the filter unit lock lever to the lock plate.
- \*3 Dust should be prevented from flying around when emptying dust bags or replacing filters. The solution for VC3211H is the filter bag already available as an optional accessory of VC3211M.
- \*4 Permeability of limestone (marble) particles having a diameter of 5 microns or less, in accordance with the EU standard



PRODUCTS



# POWER CUTTER

## More powerful than engine tools and Low vibration



### Equipped with anti-vibration housing

with built-in spring to absorb the vibration from cutting to integrated front and rear handles.



Photo: CE001G

**Low vibration**  
Front handle    Rear handle  
**2.0/1.2**  
m/s  
[ Concrete cutting ]

### Concrete cutting speed

CE001G	<b>125</b>	
Predecessor engine model	100	
slow	speed	fast

Max cutting depth  
**127 mm**

### AFT

#### Active Feedback sensing Technology

shuts down current to the motor to protect user, if the rotation speed suddenly slows down (in the case of kick-back, etc.).

### XPT

#### eXtreme Protection Technology

Enhanced Dust and Drip-proof Performance ensure reliable operation even under bad weather.

### WG / IPX4

WET GUARD

High water-resistance allows to operate the machine even if it is wet with water.



### CE001GZ01 355mm (14") Cordless Power Cutter

New

40Vmax X2 (80Vmax) XGT BL Cordless 355 mm Power Cutter, Electric Brake

Li-ion Ah 8.0 | 5.0 | 4.0 | 2.5 | 2.0

Wheel Diameter	355 mm (14")
Max Cutting Capacity	127 mm (5")
No Load Speed (RPM)	5,300
Dimensions (L x W x H)	786 x 272 x 433 mm (31 x 10-3/4 x 17")
Net weight	12.3 - 12.9 kg (27.2 - 28.5 lbs.)



40Vmax x2



Hex Wrench, Flange, Water Hose Connector, Z: Battery and Charger are sold separately

### DCE090ZX2 / Z 230mm (9") Cordless Power Cutter

BL motor delivers 6,000 RPM

Li-ion Ah 6.0 | 5.0 | 3.0 | 1.5

Wheel Diameter	230 mm (9")
Wheel Hole Diameter	22.23 mm (7/8")
Max Wheel Thickness	3.0 mm (1/8")
Max Cutting Capacity	88 mm (3-1/2")
No Load Speed (RPM)	6,600
Dimensions (L x W x H)	554x241x283mm (21-3/4"x9-1/2"x11-1/8")
Net weight	5.6 - 6.3 kg (12.3 - 13.9 lbs.)



18V x2



Hex Wrench, Flange, Water Hose Connector, Z: Battery and Charger are sold separately

PRODUCTS



# PRESSURE WASHER

## DHW080ZK Cordless High Pressure Washer

18V X2 LXT BL Cordless 8 MPa High Pressure Washer

Li-ion 6.0 5.0 3.0 1.5



Max Pressure	8.0 MPa (N/A bars)
Max Flow Rate	380 L/h (6.3 L/min)
Pump Speed (RPM)	High / Low: 3,450 / 2,390
Max Feed Temperature	40 °C (N/A °F)
Max Suction Height	1 m (3.3 ft.)
High Pressure Hose Length	5 m (16 ft.)
Sound Power Level	70.9 dB(A)
Dimensions (L x W x H)	438x218x269 mm (17-1/4"x8-5/8"x10-5/8")
Net weight	7.1 - 7.7 kg (15.6 - 17.0 lbs.)

18V x2



Trigger Gun, High Pressure Hose 5 m, Suction Hose, Cleaner Pin, Storage Box, Variable nozzle, Connector, One touch joint, Battery, Charger, Z: Battery and Charger are sold separately

## HW102 High Pressure Washer

Lightweight and compact power washer for home use



Continuous Rating Input	1,300W
Max Pressure	100bar (1,450 PSI)
Max Flow Rate	360 L/hr
Motor Type	Universal
Sound Power Level	94dB(A)
Max Input Temperature	50°C
High Pressure Hose Length	5m
Net Weight	5.8kg (5.0lbs)



## Cordless High Pressure Washer DHW080



**No power outlet required, No water source required.**

Cars, walls, steps, etc. can be cleaned anywhere at any time.



Working Pressure

**5.5 / 3.0**  
( High / Low ) MPa

Storage example



Variospray lance set

Cyclone jet nozzle set

Wash brush set

Foam nozzle set

Variable nozzle set

Pipe cleaning hose

Max tank capacity  
**50L** about

Free from cord



Supplying water from a tank/reservoir



Under body spray lance set

Rotating brush set

Optional accessories can be purchased separately.

## HW132 High Pressure Washer

Steel reinforced spray gun



Continuous rating input	2,100W
Max Pressure	14 MPa (140 bar, 2,030 PSI)
Net weight	18.8 kg (41.4 lbs)

## HW151 High Pressure Washer

Compact design, large operating range and efficient cleaning performance



Continuous Rating Input	2,500W
Max Pressure	150MPa (2,175 PSI)
Max Flow Rate	500 L/hr
Motor Type	Induction
Sound Power Level	88dB(A)
Max Input Temperature	50°C
High Pressure Hose Length	10m(32.8ft)
Net Weight	26.9kg (23.3lbs)

## PRODUCTS

## HEAT GUN

## DHG181ZK Cordless Heat Gun

New

Max 550 degrees Celsius air temperature for a wide range of cordless works

Li-ion 6.0 5.0 3.0 1.5



Air Temperature (°C)	550°C
Air Flow	Stage 1: 120 L/min Stage 2: 200 L/min
Dimensions (L x W x H)	w/o Battery: 173 x 79 x 208 mm (6-3/16 x 3-1/8 x 8-3/16") w/ BL1815N / BL1820B: 173 x 79 x 237 mm (6-3/16 x 3-1/8 x 9-3/8") w/ BL1830B / BL1850B / BL1860B: 173 x 79 x 255 mm (6-3/16 x 3-1/8 x 10")
Net weight	1.0 - 1.3 kg (2.2 - 2.9 lbs.)

18V



Glass protection nozzle, Wide slot nozzle, Reflector nozzle, Reduction nozzle, Battery, Charger, Z: Battery and Charger are sold separately

## DHG180ZK Cordless Heat Gun

New

Max 550 degrees Celsius air temperature for a wide range of cordless works

Li-ion 6.0 5.0 3.0 1.5



Air Temperature (°C)	550°C
Air Flow	200 L/min
Dimensions (L x W x H)	w/o Battery: 168 x 79 x 205 mm (6-5/8 x 3-1/8 x 8-1/8") w/ BL1815N / BL1820B: 168 x 79 x 234 mm (6-5/8 x 3-1/8 x 9-1/4") w/ BL1830B / BL1850B / BL1860B: 168 x 79 x 251 mm (6-5/8 x 3-1/8 x 9-7/8")
Net weight	1.0 - 1.3 kg (2.2 - 2.9 lbs.)

18V



Glass protection nozzle, Wide slot nozzle, Reflector nozzle, Reduction nozzle, Battery, Charger, Z: Battery and Charger are sold separately

## HG5030 Heat Gun

2-temperature settings (350 and 500 °C) for a variety of applications



Continuous rating input	1,600W
Air Temperature (°C) / Flow (L/min)	Switch 1: 350 / 300 Switch 2: 500 / 500
Dimensions (L x W x H)	233x80x208 mm (9-1/8"x3-1/8"x8-3/16")
Net weight	0.56 kg (1.2 lbs.)
Power supply cord	2.0 m (6.6 ft)



Glass protection nozzle, Reflector nozzle, Reduction nozzle, Wide slot nozzle, Scraper

## HG6030K Heat Gun

2-speed blower settings (250 and 500 L/min) for greater versatility



Continuous rating input	1,800W
Air Temperature (°C) / Flow (L/min)	Switch 1: 50 / 250 Switch 2: 300 / 250 Switch 3: 600 / 500
Dimensions (L x W x H)	233x80x208 mm (9-1/8"x3-1/8"x8-3/16")
Net weight	0.57 kg (1.3 lbs.)
Power supply cord	2.0 m (6.6 ft)







HG6031VK Heat Gun

2-speed blower settings (250 and 500 L/min) for greater versatility



Continuous Rating Input	1,800W
Air Temperature (°C)	High: 600 Low: 300 Medium: 50
Flow (L/min)	High: 500 Low: 250 Medium: 250
Dimensions (L x W x H)	257x85x206 mm (10-1/8"x3-3/8"x8-1/8")
Net Weight	0.67 kg (1.5 lbs)
Power Supply Cord	2.0 m (6.6 ft)



Glass protection nozzle, Reflector nozzle, Reduction nozzle, Wide slot nozzle

HG6530VK Heat Gun

Durable and powerful heat gun with variable temperature control and LCD display



Continuous rating input	2,000W
Air Temperature (°C)	50 - 650
Air Flow	Stage 1: 280 L/min Stage 2: 280 L/min Stage 3: 550 L/min
Dimensions (L x W x H)	253x85x205 mm (10"x3-3/8"x8-1/8")
Net weight	0.73 kg (1.6 lbs.)
Power supply cord	2.0 m (6.6 ft)



Glass protection nozzle, Wide slot nozzle, Reflector nozzle (Nozzle B)

HG6531CK Heat Gun

New

Durable and powerful heat gun with variable temperature control and LCD display



Continuous rating input	2,000W
Air Temperature (°C)	50 - 650
Air Flow	200 - 550 L/min
Dimensions (L x W x H)	257x85x206 mm (10-1/8"x3-3/8"x8-1/8")
Net weight	0.71 kg (1.6 lbs.)
Power supply cord	2.0 m (6.6 ft)



Glass protection nozzle, Wide slot nozzle, Reflector nozzle (Nozzle B)

PRODUCTS



NAILER

PT001GD201(RD2K) / GZ Cordless Pin Nailer

New

40Vmax XGT BL 23 GA 35 mm (1-3/8") Pin Nailer

Li-ion Ah 8.0 | 5.0 | 4.0 | 2.5 | 2.0



Capacity	Length: 15, 18, 25, 30, 35 mm (5/8, 11/16, 1, 1-3/16, 1-3/8") Dia.: 0.6 mm (1/32") Gauge: 23 Ga
Magazine Capacity	120
Dimensions (L x W x H)	218 x 86 x 226 mm (8-5/8 x 3-3/8 x 8-7/8")
Net weight	2.4 - 3.0 kg (5.3 - 6.6 lbs.)

40Vmax



Nose Adapter, Safety Goggles, Belt Clip, Hex Wrench, Battery, Charger,  
Z: Battery and Charger are sold separately

DPT353RTE / Z Cordless Pin Nailer

Shoots 6,400 nails on a single full BL1860B charge

Li-ion Ah 6.0 | 5.0 | 3.0 | 1.5



Capacity	Length: 15, 18, 25, 30, 35 mm (5/8", 11/16", 1-3/16", 1-3/8") Dia.: 0.6 mm (1/32") Gauge: 23 Ga
Magazine Capacity	120
Dimensions (L x W x H)	257 x 79 x 226 mm (10-1/8" x 3-1/8" x 8-7/8")
Net weight	2.0 - 2.3 kg (4.4 - 5.1 lbs)

18V



Nose Adapter, Safety Goggles, Belt Clip, Hex Wrench, Battery, Fast Charger,  
Z: Battery and Charger are sold separately



Pin Nail		A			
(mm)	0.6	← A →		0.6	
Materials	Steel				
Length (A)	18 mm	25mm	30mm	35mm	
Part No.	F-00013	F-00026	F-01819	F-00055	
Type	P18	P25	P30	P35	
Pcs/series	100pcs				
Pcs/pack	100 x 30pcs				

### PT354DSAJ / DZ Cordless Pin Nailer

12Vmax CXT Li-Ion Cordless 23 Ga 35 mm (1-3/8") Pin Nailer

Li-ion Ah 4.0 2.0 1.5



**Capacity** Length: 15, 18, 25, 30, 35 mm  
(5/8", 11/16", 1", 1-3/16", 1-3/8")  
Dia.: 0.6 mm (1/32")  
Gauge: 23 Ga

**Magazine Capacity** 120

**Dimensions** 231x66x226 mm  
(L x W x H) (9-1/8"x2-5/8"x8-7/8")

**Net weight** 1.8 - 2.0 kg (4.0 - 4.4 lbs.)

PT354DSAJ PT354DZ

12Vmax



Nose Adapter, Safety Goggles, Belt Clip, Hex Wrench, Battery, Charger, DZ: Battery and Charger are sold separately

### AF201Z 25mm (1") Pin Nailer

Applicable for finishing jobs



**Capacity** Length: 12-25 mm (15/32" - 1")

**Magazine Capacity** 100

**Operating Pressure** 0.44-0.86 MPa (65-125 PSI)

**Dimensions** 240x45x170 mm  
(L x W x H) (9-1/2"x1-3/4"x6-3/4")

**Net weight** 0.9 kg (2.0 lbs.)



Oil supply, Hex Wrench

### AF353 35mm (1-3/8") Pneumatic Pin Nailer

23 GA Pneumatic Pin Nailer, Air Duster



**Capacity - Length** 15 - 35 mm (5/8" - 1-3/8")  
Gauge 23 Ga

**Operating Pressure** 0.45 - 0.69 MPa  
(65 - 100 PSI)

**Magazine Capacity** 130

**Dimensions** 208x66x191 mm  
(L x W x H) (8-3/16"x2-5/8"x7-1/2")

**Net Weight** 0.9 kg (2.0 lbs)



Safety Goggles, Oil supply (country-specific), Nose Adapter, Hex Wrench

### FN001GD101 (RDK) / GZ Cordless Brad Nailer

40Vmax XGT BL Cordless 18 Ga 40 mm (1-5/8") Brad Nailer

Li-ion Ah 8.0 5.0 4.0 2.5 2.0



FN001GD101



FN001GZ



**Capacity** Length: 15 - 40 mm  
(5/8 - 1-5/8")  
Gauge: 18 Ga

**Magazine Capacity** 100

**Shot q'ty on a single full battery charge** 4,000

**Dimensions** (L x W x H)  
w/ BL4025: 265 x 83 x 244 mm  
(10-3/8 x 3-1/4 x 9-5/8")  
w/ BL4040: 271 x 100 x 244 mm  
(10-5/8 x 3-15/16 x 9-5/8")

**Net weight** 2.6 - 2.9 kg (5.7 - 6.4 lbs.)

40Vmax



Safety Goggles, Nose Adapter, Hex Wrench, Belt Clip, Battery, Charger, Z: Battery and Charger are sold separately

## Cordless 18 Ga 40 mm (1-5/8") Brad Nailer

Lightweight at **2.6kg** (with BL4020)



**Counterweight mechanism** reduces vibration by moving a counterweight in the opposite direction of the hammer.

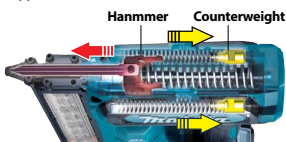

**High power** BL MOTOR  
40Vmax XGT Li-Ion battery and BL motor quickly re-compress the spring for next firing.

**Contact top designed for easy nail placement**  
Nail shooting port is located in the center of contact arm, enabling accurate nail placement.



**Slim nose** with nose adapter



**Work volume on a single full battery charge about 5,000 nails**

with battery: BL4025  
nail: Length 15-40 mm, Gauge 18 Ga



Photo: FN001G

**DFN350ZJ Cordless Brad Nailer**

18V LXT Li-Ion Cordless 18 Ga 35 mm (1-3/8") Brad Nailer

Li-ion Ah 6.0 5.0 3.0 1.5



1

Capacity	Length: 15 - 35 mm (5/8" - 1-3/8") Gauge: 18 Ga
Magazine Capacity	110
Dimensions (L x W x H)	w/ BL1815N / BL1820B: 240x79x228 mm (9-1/2"x3-1/8"x9") w/ BL1830B / BL1840B / BL1850B / BL1860B: 257x79x228 mm (10-1/8"x3-1/8"x9")
Net weight	2.1 - 2.4 kg (4.6 - 5.3 lbs.)

18V



Safety Goggles, Nose Adapter, Hex Wrench, Belt Clip, Battery, Charger, Z: Battery and Charger are sold separately

**AF301 Pneumatic Nailer**

Application: Decoration, Picture Frame, Furniture, Shoe-Making, Drawer Assembly



10

Capacity -	Length 10-30mm (13/32"-1-3/16") Width 1.25 mm (0.05") Wire 1.05 mm (0.041") Gauge 18 Ga
Tank Max Pressure	0.39-0.69 MPa (60-100 PSI)
Net Weight	1.3 kg (2.86 lbs)

With Safety Pin Preventing Accident Operation, Oil, Hex Wrench

**AF506 50mm (2") Pneumatic Brad Nailer**

16 GA Pneumatic Finish Nailer, Air Duster



4

Capacity -	Length 15 - 50 mm (5/8" - 2") Gauge 18 Ga
Operating Pressure	0.49 - 0.83 MPa (70 - 120 PSI)
Magazine Capacity	100
Dimensions (L x W x H)	250x70x256 mm (9-7/8"x2-3/4"x10-1/8")
Net Weight	1.3 kg (2.9 lbs.)

Safety Goggles, Oil supply, Nose Adapter, Hook

**AF635 64mm (2-1/2") Pneumatic Finish Nailer**

15 GA Pneumatic Finish Nailer, Air Duster



4

Capacity -	Length 32 - 64 mm (1-1/4" - 2-1/2") Gauge 15 Ga
Operating Pressure	0.49 - 0.83 MPa (70 - 120 PSI)
Magazine Capacity	100
Dimensions (L x W x H)	339x100x309 mm (13-3/8"x3-15/16"x12-1/8")
Net Weight	1.8 kg (4 lbs.)

Safety Goggles, Oil supply, Nose Adapter

**DST121ZK Cordless Stapler**

18V LXT Li-Ion Cordless 10 mm J Wire Stapler

Li-ion Ah 6.0 5.0 3.0 1.5



1

Staple	Width: 10 mm (N/A) Length: 13 - 25 mm (1/2" - 1") Size: 1.2 x 0.6 mm
Magazine capacity	100
Shot q'ty on a single full battery charge	w/ BL1860B: 4,800
Dimensions (L x W x H)	w/ BL1815N: 244x79x216 mm (9-5/8"x3-1/8"x8-1/2") w/ BL1830B / BL1850B / BL1860B: 260x79x216 mm (10-1/4"x3-1/8"x8-1/2")
Net weight	2.2 - 2.5 kg (4.9 - 5.5 lbs.)

18V



Safety Goggles, Nose Adapter, Belt Clip, Battery, Charger, Z: Battery and Charger are sold separately

**DST421ZK Cordless Stapler**

18V LXT Li-Ion Cordless 4 mm J Wire Stapler

Li-ion Ah 6.0 5.0 3.0 1.5



1

Staple	Width: 4 mm (N/A) Length: 13 - 25 mm (1/2" - 1") Size: 1.2 x 0.6 mm
Magazine capacity	100
Shot q'ty on a single full battery charge	w/ BL1860B: 4,800
Dimensions (L x W x H)	w/ BL1815N: 244x79x216 mm (9-5/8"x3-1/8"x8-1/2") w/ BL1830B / BL1850B / BL1860B: 260x79x216 mm (10-1/4"x3-1/8"x8-1/2")
Net weight	2.2 - 2.5 kg (4.9 - 5.5 lbs.)

18V



Safety Goggles, Nose Adapter, Belt Clip, Battery, Charger, Z: Battery and Charger are sold separately

**AT1022AZ Pneumatic Stapler**

Application: Cabinet Making, Case back Assembly, Drawer Assembly, Furniture



10

Capacity -	Length 10 - 22 mm (13/32" - 7/8") Gauge 18 Ga
Magazine Capacity	100
Operating Pressure	0.45 MPa (65 PSI)
Dimensions (L x W x H)	250x55x180 mm (9-3/4"x2-1/4"x7")
Net Weight	1.3 kg (2.86 lbs)

With Safety Pin Preventing Accident Operation, Oil, Hex Wrench

**AT638A 38mm (1-1/2") Narrow Crown Stapler**

18 GA Narrow Crown Stapler, Air Duster



4

Capacity -	Length 13 - 38 mm (1/2" - 1-1/2") Gauge 18 Ga Width 5.7 mm
Operating Pressure	0.49 - 0.83 MPa (70 - 120 PSI)
Magazine Capacity	100
Dimensions (L x W x H)	230x75x251 mm (9"x2-15/16"x9-7/8")
Net Weight	1.2 kg (2.7 lbs)

Safety Goggles, Oil supply, Nose Adapter



PRODUCTS

# SPECIALITY TOOLS

## DRV250Z Cordless Rivet Gun

18V LXT BL Brushless Cordless Rivet Gun

Li-ion Ah 6.0 | 5.0 | 3.0 | 1.5



Max pulling force	20 kN
Length of Stroke	30 mm (1-3/16")
Center height	26 mm (1")
Sound Pressure Level	74 dB(A)
Vibration Level	2.5 m/s <sup>2</sup> or less
Dimensions (L x W x H)	w/ BL1830B / BL1850B / BL1860B: 320x80x287 mm (12-5/8"x3-1/8"x1-1/4")
Net weight	2.1 - 2.4 kg (4.6 - 5.3 lbs.)

18V **LXT BL XPT** 1

Hook, Grease, Accessory Set, Battery, Charger, Z: Battery and Charger are sold separately

## DRV150Z Cordless Rivet Gun

18V LXT BL Brushless Cordless Rivet Gun

Li-ion Ah 6.0 | 5.0 | 3.0 | 1.5



Max pulling force	10 kN
Length of Stroke	25 mm (1")
Center height	26 mm (1")
Sound Pressure Level	75 dB(A)
Vibration Level	2.5 m/s <sup>2</sup> or less
Dimensions (L x W x H)	w/ BL1830B / BL1850B / BL1860B: 310x80x287 mm (12-1/4"x3-1/8"x1-1/4")
Net weight	1.9 - 2.2 kg (4.2 - 4.9 lbs.)

18V **LXT BL XPT** 1

Hook, Grease, Accessory Set, Battery, Charger, Z: Battery and Charger are sold separately



Photo: DRV150

### High speed riveting as same as pneumatic tools.



**Insert rivet into the hole.**

**Pull trigger to tighten the rivet.**

#### Jaw case designed to enable tight space operation

The short center height allows for tight space operation such as close-to-wall riveting.

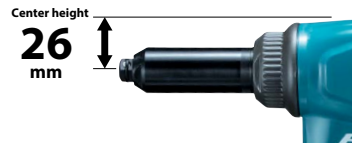

Center height  
**26 mm**



**BL MOTOR XPT**

Work amount on a full battery charge (approx)  
**2,300 rivets**  
Model: DRV150 (5.0Ah)  
DRV250: 2,000 rivets (5.0Ah)



#### Rivet holding mechanism

- Once a rivet is installed, it is held in place and do not drop out even when the tool is directed downward.
- No need for holding the rivet by hand even in vertical down application

## DGP180Z Cordless Grease Gun

Powerful motor delivers up to 69 MPa (10,000 PSI) of max pressure

Li-ion Ah 6.0 | 5.0 | 3.0 | 1.5



Max Operating Pressure	69 MPa (10,000 PSI)
Flow Rate	Slow Speed Mode: 145 mL/min (5.0 oz/min) Auto Speed Change Mode: 290 mL/min (10.0 oz/min)
Grease Capacity w/ Barrel A	Cartridge / Bulk: 410 / 455 g
Grease Capacity w/ Barrel B	Cartridge / Bulk: 450 / 570 g
Hose Length	120 cm (47-1/4")
Dimensions (L x W x H)	w/ Barrel A: 411x114x245 mm (16-1/4"x4-1/2"x9-5/8") w/ Barrel B: 449x114x245 mm (17-3/4"x4-1/2"x9-5/8")
Net weight	4.8 - 6.1 kg (10.6 - 13.4 lbs.)

18V **LXT**

Shoulder Strap, Battery, Charger, Z: Battery and Charger are sold separately

## DTR181Z Cordless Rebar Tying Tool

**New**

18V LXT BL Brushless Cordless Rebar Tying Tool

Li-ion Ah 6.0 | 5.0 | 3.0 | 1.5



Tie Wire	ø0.8 mm
Applicable Rebars	D16 x D16 - [D13 x 2] x [D16 x 2] w/ BL1830B / BL1850B / BL1860B: 317 x 93 x 318 mm (12-1/2 x 3-5/8 x 12-1/2")
Dimensions (L x W x H)	
Net weight	2.4 - 2.7 kg (5.3 - 6.0 lbs.)

18V **LXT BL XPT**

Nylon brush, Hex Wrench, Hook, Z: Battery and Charger are sold separately

**DVP181ZK Cordless Vacuum Pump**

New

Long run time of 50 minutes with a fully charged BL1850B (5.0Ah)

Li-ion Ah 6.0 | 5.0 | 3.0 | 1.5



Flow rate	113 L/min
Ultimate vacuum	3 Pa
Motor speed	3,200 min <sup>-1</sup>
Oil Tank Capacity	300 mL
Inlet port	5/16 / 3/8"
Dimensions (L x W x H)	383 x 193 x 210 mm (15-1/8 x 7-5/8 x 8-1/4")
Net weight	8.1 - 8.2 kg (17.9 - 18.1 lbs.)

18V



Vacuum Pump Oil, Adapter, Battery, Charger, Z: Battery and Charger are sold separately

**DVP180Z Cordless Vacuum Pump**

Long run time of 50 minutes with a fully charged BL1850B (5.0Ah)

Li-ion Ah 6.0 | 5.0 | 3.0 | 1.5



Flow rate	50 L/min
Ultimate vacuum	20 Pa (150 microns)
Motor speed	3,840 min <sup>-1</sup>
Oil Tank Capacity	115 mL
Inlet port	5/16"
Dimensions (L x W x H)	265x93x175 mm (10-3/8"x3-5/8"x6-7/8")
Net weight	3.5 kg

18V



Pump oil, Adapter, Battery, Fast Charger, Z: Battery and Charger are sold separately

**DCG180ZB / Z / ZK Cordless Caulking Gun**

18V LXT Li-Ion Cordless Caulking Gun

Li-ion Ah 6.0 | 5.0 | 3.0 | 1.5



Max Dispensing Force	5,000 N (1,100 lbs)
No load speed	0 - 28 mm/sec. (0 - 66 in/min.)
Holder Size	300, 600, 800 mL
Dimensions (L x W x H)	404x108x281 mm (15-7/8"x4-1/4"x11-1/8")
Net weight	2.1 - 3.0 kg (4.7 - 6.6 lbs)

DCG180ZB

18V



Fast Charger, Battery Cartridge, Holder, Holder Joint, Piston, Rubber Ring, Nozzle, Z: Battery and Charger are sold separately

**CG100DZA Cordless Caulking Gun**

12Vmax CXT Li-Ion Cordless Caulking Gun

Li-ion Ah 4.0 | 2.0 | 1.5



Max Dispensing Force	5,000 N (1,100 lbs)
No load speed	0 - 28 mm/sec. (0 - 66 in/min.)
Holder Size	300, 600, 800 mL
Dimensions (L x W x H)	404x108x259 mm (15-7/8"x4-1/4"x10-1/4")
Net weight	1.9 - 2.6 kg (4.2 - 5.8 lbs)

12Vmax



Holder, Holder Joint, Piston, Rubber Ring, Nozzle, Battery, Charger, DZ: Battery and Charger are sold separately

**DTM52RTJX2 / Z Cordless Multi Tool**

Tool-less accessory clamp for quick installation and replacement

Li-ion Ah 6.0 | 5.0 | 3.0 | 1.5



Oscillations Per Minute (OPM)	10,000 - 20,000
Oscillation Angle	Left / Right / Total: 1.8° / 1.8° / 3.6°
Dimensions (L x W x H)	w/ BL1830B / BL1850B / BL1860B: 322 x 95 x 126 mm (12-5/8 x 3-3/4 x 5")
Net weight	1.7 - 2.0 kg (3.7 - 4.4 lbs.)

18V



LXT BL AVT XPT

Oscillating Multi Tool Accessories, Dust Attachment (country-specific), Tool Box (country-specific), Battery, Charger, Z: Battery and Charger are sold separately

**DTM51Z Cordless Multi Tool**

Tool-less accessory clamp for quick installation and replacement

Li-ion Ah 6.0 | 5.0 | 3.0 | 1.5



Oscillations Per Minute (OPM)	6,000 - 20,000
Oscillation Angle	Left / Right / Total: 1.6° / 1.6° / 3.2°
Sound Power Level	Plunge Saw Blade: 92 dB(A) Scraping: 91 dB(A)
Dimensions (L x W x H)	340x80x122 mm (13-3/8"x3-1/8"x4-13/16")
Net weight	2.0 - 2.4 kg (4.4 - 5.3 lbs)

18V



Fast Charger, Battery Cartridge, Oscillating Multi Tool Accessories, Hex Wrench, Z: Battery and Charger are sold separately

**Extra versatility**

DTM52 Compatible with STARLOCK MAX accessories



STARLOCK MAX



Cutting plasterboards



Deep plunge cutting



Wood flush cutting



Pocket cutting



Cutting PVC, FRP pipes



Routing joints on wall tiles



Removal of window frame



Door opening work



Cutting metals



Copper pipe flush cutting



Cutting window putty, silicone



Sanding and polishing



## TM3010CX6 Multi Tool

320 W Toolless Multi Tool

459



Continuous rating input	320W
Strokes Per Minute (SPM)	6,000 - 20,000
Dimensions (L x W x H)	283 x 68 x 87 mm (11-1/8 x 2-11/16 x 3-7/16")
Net weight	1.6 - 1.7 kg (3.7 - 3.9 lbs.)
Power supply cord	2.5 m (8.2 ft)



Oscillating Multi Tool Accessories

## CP100DSA / DZ Cordless Multi Cutter

12Vmax CXT Li-Ion Cordless Multi Cutter

Li-ion Ah 4.0 2.0 1.5



Max Cutting Capacity	6 mm (1/4")
No Load Speed (RPM)	300
Vibration Level	Cutting Cardboard: 2.5 m/s <sup>2</sup> or less
Dimensions (L x W x H)	272x66x120 mm (10-3/4"x2-5/8"x4-3/4")
Net Weight	0.72 - 0.88 kg (1.6 - 1.9 lbs)

CP100DSA CP100DZ

12Vmax



2

6

Blade, Battery, Charger, DZ: Battery and Charger are sold separately

## MP001GZ Cordless Inflator

New

3 Inflation modes (High speed, Low speed or Ball modes)

Li-ion Ah 8.0 5.0 4.0 2.5 2.0



Air Discharge Amount	200 kPa: 24 L/min 700 kPa: 12 L/min1
Max Air Pressure	1,110 kPa (161 PSI) [11.1 bar]
Hose Length	65 cm (25-1/2")
Sound Pressure	71 dB(A)
Dimensions (L x W x H)	w/BL4020 / BL4025: 320 x 108 x 231 mm (12-5/8 x 4-1/4 x 9-1/8"), w/BL4040: 329 x 108 x 231 mm (13 x 4-1/4 x 9-1/8"), w/BL4050F: 351 x 108 x 231 mm (13-3/4 x 4-1/4 x 9-1/8")
Net Weight	2.9 - 3.5 kg (6.4 - 7.7 lbs.)

40Vmax



XGT XPT

4

British Adapter, French Adapter, Ball Adapter, Swim Ring Adapter, Battery, Charger, Z: Battery and Charger are sold separately

## DMP181Z Cordless Inflator

New

18V max LXT Li-Ion Cordless Inflator

Li-ion Ah 6.0 5.0 3.0 1.5



Air Discharge Amount	200 kPa: 22 L/min 700 kPa: 11 L/min1
Max Air Pressure	1,110 kPa (161 PSI) [11.1 bar]
Hose Length	65 cm (25-1/2")
Sound Pressure	70 dB(A)
Dimensions (L x W x H)	w/BL1815N / BL1820B: 297 x 108 x 231 mm (11-3/4 x 4-1/4 x 9-1/8") w/BL1830B / BL1840B / BL1850B / BL1860B: 316 x 108 x 231 mm (12-1/2 x 4-1/4 x 9-1/8")
Net Weight	2.5 - 2.8 kg (5.5 - 6.2 lbs.)

18V



LXT XPT

4

British Adapter, French Adapter, Ball Adapter, Swim Ring Adapter, Battery, Charger, Z: Battery and Charger are sold separately

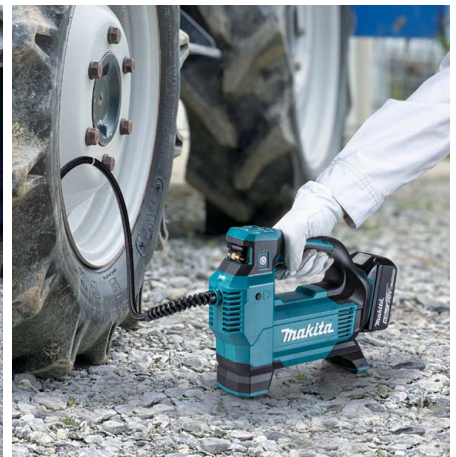

## DMP180Z Cordless Inflator

18V max LXT Li-Ion Cordless Inflator

Li-ion Ah 6.0 5.0 3.0 1.5



Max Air Pressure	830 kPa (121 PSI)
Air Discharge amount	200 kPa: 10 L/min
Dimensions (L x W x H)	w/BL1830B / BL1850B / BL1860B: 270x76x175 mm (10-5/8"x3"x6-7/8")
Net weight	1.5 - 1.8 kg (3.3 - 4.0 lbs.)

18V



LXT

4

British Adapter, French Adapter, Ball Adapter, Swim Ring Adapter, Battery, Charger, Z: Battery and Charger are sold separately

## MP100DZ Cordless Inflator

12Vmax CXT Li-Ion Cordless Inflator

Li-ion Ah 4.0 2.0 1.5



Max Air Pressure	830 kPa
Air Discharge amount	200kPa: 10 L/min
Dimensions (L x W x H)	w/BL1016/BL1021B: 235x74x173 mm (9-1/4"x2-15/16"x6-13/16") w/BL1041B: 255x74x173 mm (10"x2-15/16"x6-13/16")
Net weight	1.2 - 1.3 kg (2.6 - 3.0 lbs.)

12Vmax



CXT

4

Valve adapter, Ball adapter, Floating tube adapter, DZ: Battery and Charger are sold separately



PRODUCTS



# MEASURING/ LEVELING

## Green Laser Series

Powered by the following 12V max slide CXT Li-ion batteries



### SK40GD / SK20GD / SK10GD

SK40GD

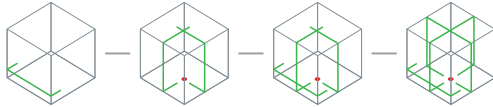

SK20GD

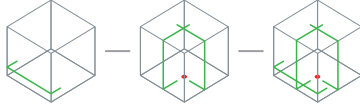

SK10GD

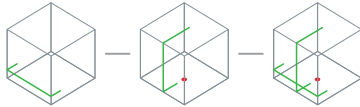

Stand



Brightness indicator

Normal

Eco mode

Laser line selection



Line beam mode selection

### Continuous runtime

SK40GD / SK20GD / SK10GD

6 / 9 / 12 h

BL1016  
Normal

12 / 16 / 20 h

BL1016  
Eco mode

Leveling accuracy  $\pm 1\text{mm}/10\text{m}$

SK312GD

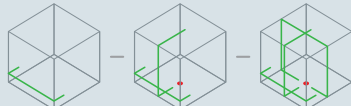

SK209GD



### Continuous runtime

SK312GD / SK209GD

10 / 15 h

BL1016  
Bright

16 / 23 h

BL1016  
Normal

21 / 28 h

BL1016  
Eco mode

Leveling accuracy  $\pm 1\text{mm}/10\text{m}$



High brightness green laser for increased visibility at bright site

### SK312GDZ Rechargeable Green Multi Line Laser

12Vmax CXT Li-Ion Rechargeable Green Multi Line Laser

Li-ion Ah 4.0 2.0 1.5



Leveling Accuracy	$\pm 1\text{mm}/10\text{m}$
Self-Leveling Range	$\pm 2^\circ$
Laser Fan Angle	Horizontal: $110^\circ$ Vertical: $130^\circ$
Number of Laser Lines	3
Laser Type	Laser class 2: 515 nm
Operating Temperature	$-10 - 40^\circ\text{C}$
Tripod Thread	5/8"
Operating Time	10-28 hours
Dimensions (L x W x H)	w/ BL1016/BL1021B: 122x110x225 mm (4-13/16"x4-5/16"x8-7/8") w/ BL1041B: 122x130x225 mm (4-13/16"x5-1/8"x8-7/8")
Net Weight	1.5 - 1.6 kg (3.3 - 3.5 lbs)

12Vmax



Glasses for laser, Shoulder Belt, Storage Case, DZ: Battery and Charger are sold separately

### SK209GDZ Rechargeable Green Multi Line Laser

12Vmax CXT Li-Ion Rechargeable Green Multi Line Laser

Li-ion Ah 4.0 2.0 1.5



Leveling Accuracy	$\pm 1\text{mm}/10\text{m}$
Self-Leveling Range	$\pm 2^\circ$
Laser Fan Angle	Horizontal: $110^\circ$ Vertical: $130^\circ$
Number of Laser Lines	3
Laser Type	Laser class 2: 515 nm
Operating Temperature	$-10 - 40^\circ\text{C}$
Tripod Thread	5/8"
Operating Time	15-40 hours
Dimensions (L x W x H)	w/ BL1016/BL1021B: 122x110x225 mm (4-13/16"x4-5/16"x8-7/8") w/ BL1041B: 122x130x225 mm (4-13/16"x5-1/8"x8-7/8")
Net Weight	1.5 - 1.6 kg (3.3 - 3.5 lbs)

12Vmax



Glasses for laser, Shoulder Belt, Storage Case, DZ: Battery and Charger are sold separately

## SK10GDZ Rechargeable Green Multi Line Laser

New

Bright green laser for increased visibility

Li-ion Ah 4.0 2.0 1.5



Leveling Accuracy	±1 mm / 10 m
Self-Leveling Range	±4°
Laser Fan Angle	Horizontal: 110° Vertical: 130°
Laser line selection	4V1H / 2V1H / 1V1H
Laser Type	Laser class 2: 515 nm
Operating Temperature	-10 - 40 °C
Protection class	IP54
Operating Time	BL1016: 12 hours
Dimensions (L x W x H)	w/ BL1016/BL1021B: 98x223 mm
Net Weight	1.4 - 1.6 kg (3.1 - 3.5 lbs)

12Vmax

CXT XPT

6

Laser detector, Laser Receiver Vise, Laser Viewing Glass, Shoulder Strap, Storage Case, Battery, DZ: Battery and Charger are sold separately

## SK20GDZ Rechargeable Green Multi Line Laser

New

Bright green laser for increased visibility

Li-ion Ah 4.0 2.0 1.5



Leveling Accuracy	±1 mm / 10 m
Self-Leveling Range	±4°
Laser Fan Angle	Horizontal: 110° Vertical: 130°
Laser line selection	4V1H / 2V1H / 1V1H
Laser Type	Laser class 2: 515 nm
Operating Temperature	-10 - 40 °C
Protection class	IP54
Operating Time	BL1016: 9 hours
Dimensions (L x W x H)	w/ BL1016/BL1021B: 98x223 mm
Net Weight	1.4 - 1.6 kg (3.1 - 3.5 lbs)

12Vmax

CXT XPT

6

Laser detector, Laser Receiver Vise, Laser Viewing Glass, Shoulder Strap, Storage Case, Battery, DZ: Battery and Charger are sold separately

## SK40GDZ Rechargeable Green Multi Line Laser

New

Bright green laser for increased visibility

Li-ion Ah 4.0 2.0 1.5



Leveling Accuracy	±1 mm / 10 m
Self-Leveling Range	±4°
Laser Fan Angle	Horizontal: 110° Vertical: 130°
Laser line selection	4V1H / 2V1H / 1V1H
Laser Type	Laser class 2: 515 nm
Operating Temperature	-10 - 40 °C
Protection class	IP54
Operating Time	BL1016: 6 hours
Dimensions (L x W x H)	w/ BL1016/BL1021B: 98x223 mm
Net Weight	1.4 - 1.6 kg (3.1 - 3.5 lbs)

12Vmax

CXT XPT

6

Laser detector, Laser Receiver Vise, Laser Viewing Glass, Shoulder Strap, Storage Case, Battery, DZ: Battery and Charger are sold separately

## SK700GDZ / DZ Rechargeable Green / Red Multi Line Laser

New

3 x full 360-degree lines for quick and easy setup

Li-ion Ah 4.0 2.0 1.5



Leveling accuracy	±2 mm / 10 m
Self-leveling rang	±4°
Laser type	SK700GD: Laser class 2: 510 - 530 nm SK700D: Laser class 2: 630 - 645 nm
Operating Temperature	-10 - 50 °C
Protection class	IP54
Dimensions (L x W x H)	w/ BL1016/BL1021B: 149 x 104 x 153 mm (5-7/8 x 4-1/8 x 6") w/ BL1041B: 168 x 104 x 153 mm (6-5/8 x 4-1/8 x 6")
Net weight	0.99 - 1.2 kg (2.2 - 2.7 lbs.)

12Vmax

CXT XPT

7

Target Plate, Adapter, Soft Bag, DZ: Battery and Charger are sold separately

## SK105GDZ Rechargeable Green / Red Cross Line Laser

High brightness green laser for increased visibility at bright site

Li-ion Ah 4.0 2.0 1.5



Measuring range	Up to: 35 m
Measuring range w/detector	Up to: 80 m
Leveling accuracy	±3 mm / 10 m
Self-leveling range	±4°
Number of laser lines	2
Laser type	Laser class 2 : 525 nm
Operating temperature	-10 - 50 °C
Operating Time (Approx. Hrs)	7 - 20
Dimensions (L x W x H)	w/ BL1016/BL1021B : 113x64x102 mm w/ BL1041B: 157x64x102 mm
Net weight	0.67 - 0.84 kg

12Vmax

CXT XPT

10

Soft bag, Adapter, Target Plate, DZ: Battery and Charger are sold separately

## LD030P 30m Laser Distance Measure

Measuring accuracy and productivity



Measuring Range	0.2-30m
Operating Temperature	0 - 40°C
Storage Temperature	-25 - 70°C
Typical Measuring	±2.0mm / 10m
Tolerance	
Max Measuring	±3.0mm / 10m
Tolerance	
Diameter Of Laser Point	6mm / 10m
Laser Type	Laser class 2: 635nm
Dimensions	117x53x25mm
(H x D x W)	(4.5"x2.14"x1")
Net Weight	0.1 kg (0.22lbs)

20

Alkaline Battery (2), Carrying Strap

## LD050P 50m Laser Distance Measure

Measuring accuracy and productivity



Measuring Range	0.05-50m
Power Supply	Cell battery: AAA 1.5V x 2pcs
Net Weight	0.1 kg (0.22lbs)

10

Alkaline Battery (2), Carrying StrapFront Cuffs 24, Poly Bag Set

## LD080P 80m Laser Distance Measure

Measuring accuracy and productivity



Measuring Range	0.05-80m
Power Supply	Cell battery : AAA 1.5V x 2pcs
Net Weight	0.14kg (0.31lbs)

10

Alkaline Battery (2), Carrying Strap

PRODUCTS

COMFORT/  
LIFESTYLE

CF002GZ 330mm (13") Cordless Fan

New

Increased max air velocity 240 m/min

Li-ion Ah 8.0 | 5.0 | 4.0 | 2.5 | 2.0



Continuous Use (min.) w/o oscillation	w/ BL4040: Low / Mid / High: 1,020 / 640 / 320
Continuous Use (min.) w/ oscillation	w/ BL4040: Low / Mid / High: 970 / 610 / 305
Max Air Velocity	High / Mid / Low: 240 / 170 / 120 m/min
Air Flow	High / Mid / Low: 21 / 15 / 10 m <sup>3</sup> /min
Noise level	52 dB(A)
Fan Diameter	330 mm (13")
Dimensions (L x W x H)	w/ BL4040: 277 x 439 x 602 mm
Net weight	3.8 - 5.1 kg (8.4 - 11.2 lbs.)

40Vmax



AC Adaptor, Z: Battery and Charger are sold separately

CF001GZ 235 mm (9-1/4") Cordless Fan

40Vmax XGT Automatic Swing Fan

Li-ion Ah 8.0 | 5.0 | 4.0 | 2.5 | 2.0



Continuous Use (min.) w/o oscillation	w/ BL4040 Low / Mid / High: 1,160 / 880 / 660 w/ BL4025 Low / Mid / High: 730 / 550 / 410
Continuous Use (min.) w/ oscillation	w/ BL4040 Low / Mid / High: 1,055 / 800 / 600 w/ BL4025 Low / Mid / High: 665 / 500 / 370
Max Air Velocity	High / Med / Low: 190 / 150 / 120 m/min
Air Flow	High / Med / Low: 8.2 / 6.5 / 5.2 m <sup>3</sup> /min
Dimensions (L x W x H)	143x333x463 mm (5-5/8"x13"x18-1/4")
Net weight	2.0 - 3.0 kg (4.4 - 6.6 lbs.)

40Vmax



AC Adaptor, Z: Battery and Charger are sold separately

DCF301Z 330mm (13") Cordless Fan

New

Increased max air velocity 240 m/min

Li-ion Ah 6.0 | 5.0 | 3.0 | 1.5



Continuous Use (min.) w/o oscillation	w/ BL1860B: Low / Mid / High: 850 / 430 / 215
Continuous Use (min.) w/ oscillation	w/ BL1860B: Low / Mid / High: 815 / 415 / 210
Max Air Velocity	High / Mid / Low: 240 / 170 / 120 m/min
Air Flow	High / Mid / Low: 21 / 15 / 10 m <sup>3</sup> /min
Noise level	52 dB(A)
Fan Diameter	330 mm (13")
Dimensions (L x W x H)	w/ BL1860B: 269 x 439 x 602 mm
Net weight	3.8 - 4.5 kg (8.4 - 9.9 lbs.)

18V

14.4V



AC Adaptor, Z: Battery and Charger are sold separately

DCF203Z 235 mm (9-1/4") Cordless Fan

Automatic Swing Fan

Li-ion Ah 6.0 | 5.0 | 3.0 | 1.5



Max Continuous Use (min.)	w/ BL1860B: Low / Medium / High: 1,010 / 650 / 410
Max Air Velocity	High / Med / Low: 190 / 150 / 120 m/min
Air Flow	High / Med / Low: 8.2 / 6.5 / 5.2 m <sup>3</sup> /min
Dimensions (L x W x H)	140x333x447 mm (5-1/2"x13"x16-1/2")
Net weight	1.9 - 2.6 kg (4.2 - 5.6 lbs.)

18V

14.4V



Z: Battery and Charger are sold separately

DCF102ZX1 180 mm (7-1/8") Cordless Fan

Automatic Swing Fan

Li-ion Ah 6.0 | 5.0 | 3.0 | 1.5



Max Continuous Use (min.)	w/ BL1860B: Low / Medium / High: 1,270 / 705 / 575
Dimensions (L x W x H)	185x272x284 mm (7-1/4"x10-3/10"x11-1/8")
Net weight	1.3 - 2.0 kg (2.9 - 4.4 lbs.)

18V



Z: Battery and Charger are sold separately

CF101DZ / DZX1 180mm (7-1/8") Cordless Fan

Automatic Swing Fan

Li-ion Ah 4.0 | 2.0 | 1.5



Max Continuous Use (min.)	w/ BL1041B: Low / Medium / High: 630 / 380 / 275
Dimensions (L x W x H)	185x260x284 mm (7-1/4"x10-1/4"x11-1/8")
Net weight	1.3 - 1.7 kg (2.8 - 3.8 lbs.)

12Vmax



DZ: Battery and Charger are sold separately



**CF100DZ** 180mm (7-1/8") Cordless Fan

12V max CXT Li-Ion Cordless 180 mm (7-1/8") Fan

Li-ion Ah 4.0 | 2.0 | 1.5



Continuous Use (min.)	BL1041B: Low / Medium / High: 630 / 380 / 275
	BL1021B: Low / Medium / High: 315 / 190 / 135
Dimensions (L x W x H)	BL1016: Low / Medium / High: 240 / 145 / 105
	w/o Battery: 148x260x252 mm (5-7/8x10-1/4x9-7/8")
Net Weight	1.2 - 1.4 kg (2.7 - 3.1 lbs)

12Vmax



AC Adaptor, DZ: Battery and Charger are sold separately

**DCM501Z** Cordless Coffee Maker

Either CXT battery or LXT battery is used

Li-ion Ah 6.0 | 5.0 | 3.0 | 1.5



Water Tank Capacity	240 mL
Compatible Cafe Pod Type	60 mm
Dimensions (L x W x H)	w/ BL1041B: 243x185x218 mm (9-9/16"x7-5/16"x8-9/16") w/ BL1830B / BL1850B / BL1860B: 243x187x218 mm (9-9/16"x7-3/8"x8-9/16")
Net weight	1.9 - 2.2 kg (4.1 - 4.8 lbs)

18V

12Vmax



Mug, Measuring Spoon, Z: Battery and Charger are sold separately

**CW002GZ** Cordless Cooler & Warmer Box

New

Large 50 L capacity

Li-ion Ah 8.0 | 5.0 | 4.0 | 2.5 | 2.0



Capacity	50L (13.2 gal)
Cooling Capacity	-18/-15/-10/-5/0/5/ 10°C (0/5/15/25/30/40/ 50°F)
Warming System	30/35/40/45/50/55/ 60°C (85/95/105/115/ 120/130/140°F)
Run Time	w/ BLBL4040, -18/5/ 60°C: 8 / 19.5 / 4.5
Cord Length	AC Adapter / Cigar Socket Cable: 2 / 2.5 m (6.5 / 8.2 ft)
Storage dimensions (L x W x H)	500 x 320 x 320 mm (19-3/4 x 12-5/8 x 12-5/8")
Dimensions (L x W x H)	867 x 465 x 476 mm (34-1/8 x 18-1/4 x 18-3/4")
Net weight	25.6 - 29.0 kg (56.4 - 63.9 lbs.)

40Vmax 18V



Cigar Socket Cable, Z: Battery and Charger are sold separately

**CW001GZ** Cordless Cooler & Warmer Box

New

Powered by 4 sources: 40Vmax / 18V / 12V/24V DC (cigar socket) / AC

Li-ion Ah 8.0 | 5.0 | 4.0 | 2.5 | 2.0



Capacity	20L (5.3 gal)
Cooling System	Compressor type
Cooling Capacity	-18/-15/-10/-5/0/5/ 10°C
Warming System	Heater
Warming Capacity	30/35/40/45/ 50/55/60°C
Run Time	w/ BL4050FX2, -18°C/5°C/60°C: 10h/28h/8.5h
Cord Length	AC Adapter / Cigar Socket Cable: 2 / 2.5 m (6.5 / 8.2 ft)
Dimensions (L x W x H)	663x341x372 mm (26-1/8x13-3/8x14-5/8")
Net weight	13.5 - 16.1 kg (29.8 - 35.5 lbs.)

40Vmax 18V



Shoulder Belt, Cigar Socket Cable, Z: Battery and Charger are sold separately

**CW003GZ** Cordless Cooler & Warmer Box

New

Compact design, 7 L capacity

Li-ion Ah 8.0 | 5.0 | 4.0 | 2.5 | 2.0



Capacity	7L (1.8 gal)
Cooling System	Compressor type
Cooling Capacity	-18/-15/-10/-5/0/5/ 10°C
Warming System	Heater
Warming Capacity	30/35/40/45/ 50/55/60°C
Run Time	w/ BLBL4040, -18/5/60°C: 5.5 / 13.5 / 5.5
Cord Length	AC Adapter / Cigar Socket Cable: 2 / 2.5 m (6.5 / 8.2 ft)
Dimensions (L x W x H)	456 x 245 x 308 mm (18 x 9-5/8 x 12-1/8")
Net weight	7.9 - 9.4 kg (17.4 - 20.7 lbs.)

40Vmax 18V



Shoulder Belt, Cigar Socket Cable, Z: Battery and Charger are sold separately

**DCW180Z** 18V / 12V / 24V Cordless Cooler and Warmer Box

Compressor type cooling system provides excellent cooling capacity

Li-ion Ah 6.0 | 5.0 | 3.0 | 1.5



Capacity	20L (5.3 gal)
Cooling System	Compressor type
Cooling Capacity	-18/-10/0/5/10°C
Warming System	Heater
Warming Capacity	55/60°C
Run Time	w/ BL1860BX2, -18°C/5°C /60°C: 5h / 17h / 4h
Cord Length	AC Adapter / Cigar Socket Cable: 2 / 2.5 m (6.5 / 8.2 ft)
Thermal Insulation Thickness	33 mm
Dimensions (L x W x H)	623x341x371.5 mm (24-1/2"x13-3/8"x14-5/8")
Net weight	13.3 - 14.3 kg (29.3 - 32.0 lbs.)

18V

12Vmax



Shoulder Belt, AC Adaptor, Cigar Socket Cable, Z: Battery and Charger are sold separately

**40Vmax LITHIUM-ION** **18V LITHIUM-ION**

**-18°C ~ 60°C [0°F ~ 140°F]**

**Keep cold, Keep hot**

CW002GZ 50L (13.2gal)

CW001GZ 20L (5.3gal)

CW003GZ 7L (1.8gal)

**IPX4-rated water resistance**

**USB output port**

**Bottle opener**

**Indication lamps**

**KT001GZ** Cordless Kettle

**New**

Powered by two or one 40Vmax XGT Li-Ion battery or PDC1200 Portable power pack

Li-ion Ah 8.0 | 5.0 | 4.0 | 2.5 | 2.0

Boiling time 8 min  
 Water Tank Capacity 800 mL  
 Dimensions (L x W x H) 233 x 322 x 307 mm (9-1/8 x 12-5/8 x 12-1/8")  
 Net weight 2.8 - 5.9 kg (6.2 - 13.0 lbs.)



2

40Vmax XGT

Z: Battery and Charger are sold separately



**DKT360Z** Cordless Kettle

**New**

Powered by two 18V LXT batteries in series

Li-ion Ah 6.0 | 5.0 | 3.0 | 1.5

Boiling time 8 min  
 Water Tank Capacity 800 mL  
 Dimensions (L x W x H) 233 x 263 x 307 mm (9-1/8 x 10-3/8 x 12-1/8")  
 Net weight 2.7 - 3.4 kg (6.0 - 7.5 lbs.)



2

18V x2 LXT

Z: Battery and Charger are sold separately

**MR006G** Job Site Radio

**New**

12Vmax-40Vmax CXT LXT XGT Li-Ion Cordless Bluetooth Job Site Radio

Li-ion Ah 8.0 | 5.0 | 4.0 | 2.5 | 2.0

Frequency Band FM/AM: 87.5 - 108 MHz / 522 - 1,710 kHz  
 Speaker Size Sides: Dia. 63.5 mm x2  
 Bottom: Dia. 101.6 mm  
 Max Output 40Vmax: 5W x2 + 25W / 18V: 5W x2 + 25W / 14.4V: 3W x2 + 15W / 12Vmax: 2W x2 + 10W  
 Bluetooth Version: 5.0  
 Profile: A2DP / SCMS-T / AVRCP  
 Supported Codec: SBC  
 Max Transmission Range: 10 m (33 ft)  
 Dimensions (L x W x H) w/ Handle in Retracted Position: 285 x 172 x 305 mm  
 Net weight 5.6 - 6.4 kg (12.3 - 14.1 lbs.)



2

Bluetooth

40Vmax 18V 14.4V 12Vmax 10.8V

XGT LXT CXT DC

AC Adaptor, AA Battery

XGT 40Vmax LITHIUM-ION

18V LITHIUM-ION

12Vmax LITHIUM-ION

**High Quality Sound**

With midrange / treble speakers on both sides and woofer on the bottom for deeper and richer sound

**7 Selectable sound modes**

- Sound mode can be selected to suit the music genre.
- MY EQ (my equalizer) mode enables to independently adjust treble, midrange and bass for a desired sound quality.
- LED color indicates the selected sound mode.

Equalizer	LED
FLAT	White
JAZZ	Blue
ROCK	Red
CLASSIC	Brown
POP	Pink
NEWS	Yellow
MY EQ	Green



Carry handle with built in FM antenna  
 • Swivels 90 degrees  
 • Features soft grip

Photo: MR006G



Bluetooth

equipped with Bluetooth class 2\*\* to wirelessly play music from a mobile device.  
 \*\*With a range of 10m (33ft); up to 30m (100ft) in good radio conditions



**AUX-IN jack** used as a stereo speaker by connecting to external audio source with a commercial connecting cable.



**USB output port**  
 • allows for charging a mobile device.  
 • Type A USB socket for DC5V/ 2.4A USB output



**Black panel with illuminated letters**



**Dust and shower-proof construction: IP65**  
 For use in outdoor applications or harsh environments



**MR002G Job Site Radio**

12Vmax-40Vmax CXT LXT XGT Li-Ion Cordless Bluetooth Job Site Radio

Li-ion Ah 8.0 5.0 4.0 2.5 2.0



2

Frequency Band	FM / AM: 87.5 - 108 MHz / 522 - 1,710 kHz
Speaker Size	Woofer: Dia. 89 mm x2
Max Output	40Vmax: 3.5 W x2
Bluetooth	Version: 5.0 Profile: A2DP / SCMS-T Supported Codec: SBC Max Transmission Range (Optimum): 10 m (33 ft) w/ Handle in Upright Position: 280 x 171 x 434 mm (11 x 6-3/4 x 17-1/8")
Dimensions (L x W x H)	
Net weight	4.6 - 5.4 kg (10.1 - 11.9 lbs.)

40Vmax 18V 14.4V 12Vmax 10.8V XGT LXT CXT DC 10

AC Adaptor, AA Battery

**DMR300 Job Site Radio**

12Vmax-18V CXT LXT Li-Ion Cordless Bluetooth Job Site Charger Radio

Li-ion Ah 6.0 5.0 3.0 1.5



Frequency Band	FM / AM: 87.5 - 108 MHz / 520 - 1,710 kHz
Speaker Size	Woofer: Ø89 mm x2
Bluetooth	Version: 4.2 Max Transmission Range (Optimum): 30 m (98 ft)
Dimensions (L x W x H)	285x185x305 mm (11-1/4"x7-1/4"x12")
Net weight	4.4 kg (9.7 lbs.)

Bluetooth

18V 14.4V 12Vmax 10.8V LXT CXT DC 10 2

AC Adaptor, AA Battery

**DMR108 Job Site Radio**

7.2V-18V CXT LXT Li-Ion Cordless Bluetooth Job Site Radio

Li-ion Ah 6.0 5.0 3.0 1.5



1

Frequency Band	FM / AM: 87.5 - 108 MHz / 522 - 1,710 kHz
Speaker Size	Woofer: Ø89 mm x2
Max Output	18V: 3.5 W x2 / 14.4V: 2.2 W x2 / 12Vmax: 1.2 W x2 / 7.2V: 0.5 W x2
Bluetooth	Version: 4.0 Profile: A2DP / SCMS-T Supported Codec: SBC Max Transmission Range: 10 m (33 ft) w/ Handle in Upright Position: 262x163x431 mm (10-3/8"x6-3/8"x17")
Dimensions (L x W x H)	
Net weight	4.4 kg (9.7 lbs.)

18V 14.4V 12Vmax 10.8V 7.2V LXT CXT DC 10

AC Adaptor, AA Battery



**DMR202 Cordless Job Site Speaker**

12Vmax / 14.4V / 18V CXT LXT Li-Ion Cordless Bluetooth Job Site Speaker

Li-ion Ah 6.0 5.0 3.0 1.5



2

Speaker Size	Woofer: Ø101.6 mm Tweeter: Ø36 mm
Bluetooth	Version: 4.0 Profile: A2DP / SCMS-T / AVRCP Supported Codec: SBC Max Transmission Range: 10 m (33 ft)
Dimensions (L x W x H)	w/ Handle in Retracted Position: 211x206x199 mm (8-5/16"x8-1/8"x7-7/8") w/ Handle in Upright Position: 211x206x286 mm (8-5/16"x8-1/8"x11-1/4")
Net weight	2.7 - 3.4 kg (5.9 - 7.3 lbs.)

18V 14.4V 12Vmax LXT CXT DC 10 2

AC Adaptor

**Multi-speaker connection**

- True Wireless Stereo (TWS) technology allows the user to wirelessly pair two DMR203's via Bluetooth multi-pairing and to enjoy a deep, rich and powerful stereo sound.
- Up to ten DMR203's can be paired and connected to one mobile device to play the same sound simultaneously.

**Color LCD panel**

- displays the status of speaker and equalizer settings.
- Displays song titles and artist names, etc.



**DMR203 Cordless Job Site Speaker**

12V max / 14.4V / 18V CXT LXT TWS Cordless Bluetooth Job Site Speaker

Li-ion Ah 6.0 5.0 3.0 1.5



2

Speaker Size	Woofer: Ø101.6 mm Tweeter: Ø36 mm
Bluetooth	Version: 5.0 Profile: A2DP / SCMS-T / AVRCP Supported Codec: SBC Max Transmission Range: 10 m (33 ft)
Dimensions (L x W x H)	w/ Handle in Retracted Position: 217x205x199 mm (8-1/2"x8-1/8"x7-7/8") w/ Handle in Upright Position: 217x205x286 mm (8-1/2"x8-1/8"x11-1/4")
Net weight	2.7 - 3.4 kg (6.0 - 7.5 lbs.)

18V 14.4V 12Vmax LXT CXT DC 10 USB

AC Adaptor, AA Battery

**DMR055 Cordless Radio with Lantern**

**New**

18V/14.4V LXT Cordless Radio with Lantern

Li-ion Ah 6.0 5.0 3.0 1.5



Frequency Band	FFM: 87.5-108 MHz / AM: 522-1,710 kHz
Speaker Size	Ø57 mm
Illuminance	Lantern, Warm white, 4 sides, High: 130 or more lx
Luminous Flux	Lantern, Warm white, 4 sides, High: 260 or more
Dimensions (L x W x H)	w/o Battery: 126 x 127 x 240 mm (5 x 5 x 9-1/2")
Net weight	1.2 - 1.6 kg (2.7 - 3.5 lbs.)

18V 14.4V LXT XPT

Strap Hook, Battery and Charger are sold separately



PRODUCTS



LIGHTS

ML009G Cordless Worklight

New

XGT LXT Li-Ion Cordless 96 LED Worklight, 10,000 Lumens

Li-ion Ah 8.0 | 5.0 | 4.0 | 2.5 | 2.0



Run Time (hrs)	w/ BL4040 x2, Low/Mid/High: 14 / 6.5 / 2.4 at 1m from the light source: 4,300 / 1,900 / 1,000 lx at 3m from the light source: 500 / 230 / 110 lx
Illuminance (High / Mid / Low)	
Luminous Flux	High / Mid / Low: 10,000 / 4,000 / 2,000 lm
Dimensions (L x W x H)	w/ Handle in Retracted Position: 248 x 386 x 305 mm, w/ Handle in Upright Position: 248 x 386 x 430 mm
Net weight	6.4 - 9.9 kg (14.1 - 21.8 lbs.)

40Vmax 18V 14.4V XGT LXT

Anti-glare film, Battery and Charger are sold separately

ML005G Cordless Worklight

New

40Vmax XGT Li-Ion Cordless LED Worklight, 3,600 Lumens

Li-ion Ah 8.0 | 5.0 | 4.0 | 2.5 | 2.0



Illuminance (High / Mid / Low)	at 1m from the light source: 2,100 / 1,000 / 500 lx
Luminous Flux	High / Mid / Low: 3,600 / 1,800 / 900 lm
Dimensions (L x W x H)	w/ Handle in Retracted Position: 248 x 309 x 296 mm (9-3/4 x 12-1/8 x 11-5/8")
Net weight	4.6 - 6.5 kg (10.1 - 14.3 lbs.)

40Vmax 18V 14.4V XGT LXT

Battery and Charger are sold separately

ML003G Cordless LED Worklight

New

High-intensity LED lights for wider range

Li-ion Ah 8.0 | 5.0 | 4.0 | 2.5 | 2.0



Run Time (hrs)	Up to: 22 (Low mode, with BL4040) at 1m from the light source: 500 / 200 lx at 0.5m from the light source: 1,900 / 800 lx
Illuminance (High / Mid / Low)	
Luminous Flux	High / Low: 1,100 / 450 lm
Dimensions (L x W x H)	w/ Handle in Retracted Position: 249x298x280mm (9-3/4"x11-3/4"x11") w/ Handle in Upright Position: 249x298x386 mm (9-3/4"x11-3/4"x15-1/4")
Net weight	3.7 - 4.7 kg (8.2 - 10.4 lbs.)

40Vmax 18V XGT LXT

Battery and Charger are sold separately

DML811 18V, 14.4V / AC Cordless Worklight

30 super luminous daylight white LEDs

Li-ion Ah 6.0 | 5.0 | 3.0 | 1.5



Run Time (hrs)	Up to: 13
Illuminance (High / Mid / Low)	at 1m from the light source: 1,800 / 800 / 350 lx at 3m from the light source: 200 / 100 / 40 lx at 5m from the light source: 85 / 40 / 17 lx
Luminous Flux	High / Mid / Low: 3,000 / 1,500 / 750 lm
Dimensions (L x W x H)	w/ Handle in Retracted Position: 249 x 302 x 271 mm (9-3/4 x 11-7/8 x 10-5/8")
Net weight	4.1 - 4.8 kg (9.0 - 10.5 lbs.)

Power Supply Cord: 2.5 m (8.2 ft)

18V 14.4V LXT 2

AC Power Cord, Battery and Charger are sold separately

DML809 18V, 14.4V / AC Cordless Worklight

Cordless 96 LED Worklight, 10,000 Lumens

Li-ion Ah 6.0 | 5.0 | 3.0 | 1.5



Run Time (hrs)	Up to: 8.5
Illuminance (High / Mid / Low)	at 1m from the light source: 3,800 / 1,500 / 800 lx at 3m from the light source: 380 / 150 / 80 lx at 5m from the light source: 150 / 60 / 30 lx
Luminous Flux	High / Mid / Low: 10,000 / 4,000 / 2,000 lm
Dimensions (L x W x H)	w/ Handle in Retracted Position: 249x370x278 mm (9-3/4"x14-1/2"x11") w/ Handle in Upright Position: 249x370x370 mm (9-3/4"x14-1/2"x14-1/2")
Net weight	5.7 - 7.0 kg (12.6 - 15.4 lbs.)

Power Supply Cord: 2.5 m (8.2 ft)

18V 14.4V LXT

AC Power Cord, Battery and Charger are sold separately

DML805 18V, 14.4V Corded and Cordless LED Worklight

L.E.D. Lights Deliver Bright and Even Lighting For Large Workspaces

Li-ion Ah 6.0 | 5.0 | 3.0 | 1.5



Run Time (hrs)	Up to: 17
Illuminance	at 0.5m from the light source Hi: 1,150 lx, Lo: 750 lx at 1m from the light source Hi: 300 lx, Lo: 200 lx Hi: 750 lm, Lo: 450 lm
Luminous Flux	
Net weight	2.3 - 2.7 kg (5.1 - 5.9 lbs.)

Power supply cord: 2.5m (8.2ft)

18V 14.4V LXT

Battery and Charger are sold separately

**DML813 / DML814 18V Cordless Worklight**

Cordless 12 LED Worklight, 3,000 Lumens

Li-ion Ah 6.0 5.0 3.0 1.5



Run Time (hrs)	w/BL1850(B) Low / Mid / High: 10 / 5.5 / 3 at 1m from the light source: 1,250 / 750 / 400 lx at 3m from the light source: 130 / 80 / 40 lx at 5m from the light source: 50 / 30 / 15 lx
Luminous Flux	High / Mid / Low: 3,000 / 1,700 / 900 lm
Dimensions (L x W x H)	Folding Position: 260x216x1,000 mm (10-1/4"x8-1/2"x39-3/8") Operating Position (Max Height): 573x658x1,250-2,240 mm (22-1/2"x26"x49-1/4"-88")
Net weight	DML813: 7.2-7.9 kg DML814: 7.4-8.1 kg

18V 14.4V

Shoulder Belt, Battery and Charger are sold separately

**DML810 18V, 14.4V / AC Cordless Area Worklight**

Cordless 202 LED Area Worklight, 5,500 Lumens

Li-ion Ah 6.0 5.0 3.0 1.5



Run Time (hrs)	Up to: 18
Illuminance (High / Mid / Low)	at 1m from the light source: 550 / 300 / 150 lx at 3m from the light source: 70 / 40 / 20 lx at 5m from the light source: 25 / 15 / 7 lx
Luminous Flux	High / Mid / Low: 5,500 / 3,000 / 1,500 lm
Dimensions (L x W x H)	420 x 420 x 787 mm (16-1/2 x 16-1/2 x 31")
Net weight	13.9 - 15.3 kg (30.6 - 33.7 lbs.)

18V 14.4V

AC Power Cord. Battery and Charger are sold separately

Power Supply Cord: 2.5 m (8.2 ft)

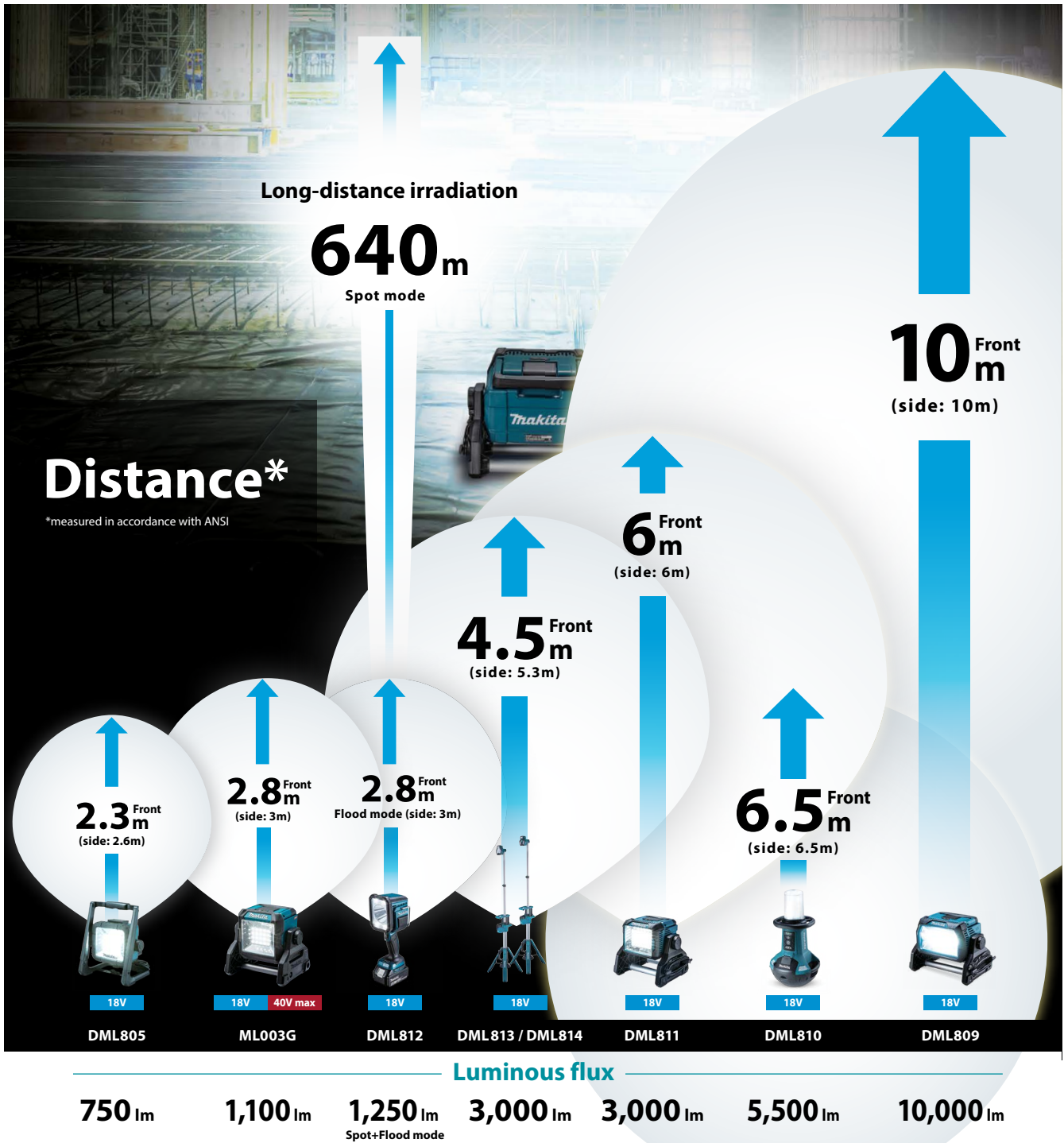

Items of standard equipment and specifications may vary by country or area. Net weight and dimensions may differ by the type of battery.

**ML007G** Cordless Flashlight

New

40Vmax XGT Li-Ion Flashlight Provides 500 Lumens

Li-ion Ah 8.0 5.0 4.0 2.5 2.0



Run Time (hrs)	Up to: 14 (Spot, with BL4050F)
Illuminance	Spot / Flood / Spot-Flood: 82,000 / 520 / 60,000 lx
Luminous Flux	Spot / Flood / Spot-Flood: 600 / 1,000 / 1,250 lm w/ BL4025:
Dimensions (L x W x H)	330 x 120 x 118 mm (13 x 4-3/4 x 4-5/8")
Net weight	1.6 - 2.9 kg (3.5 - 6.4 lbs.)

40Vmax XGT XPT

Battery and Charger are sold separately

**DML812** 18V, 14.4V Cordless Flashlight

LED Flashlight, 1,250 Lumens

Li-ion Ah 6.0 5.0 3.0 1.5



Run Time (hrs)	Up to: 10 (Spot, with BL1860B) at 1m from the light source
Illuminance	Spot Mode/ Flood Mode/ Spot-Flood Mode: 71,000/ 520/ 51,000 lx
Luminous Flux	Spot Mode/ Flood Mode/ Spot-Flood Mode: 600/ 1,000/ 1,250 lm w/ BL1830B/ BL1850B/ BL1860B:
Dimensions (L x W x H)	313x119x115 mm (12-3/8"x4-11/16"x4-1/2")
Net weight	1.2-1.6 kg (2.6-3.4 lbs.)

18V 14.4V LXT XPT 8

Strap Hook. Battery and Charger are sold separately

Illuminance: at 1m from the light source

**ML001G** LED Flashlight

40Vmax XGT Li-Ion LED Flashlight, 160 Lumens

Li-ion Ah 8.0 5.0 4.0 2.5 2.0



Run Time (hrs)	Up to: 55
Luminous Flux	160 lm
Illuminance	at 1m from the light source: 3,000 lx
Dimensions (L x W x H)	w/ BL4025: 281 x 88 x 121 mm (11-1/8 x 3-1/2 x 4-3/4") w/ BL4040: 287 x 88 x 136 mm (11-1/4 x 3-1/2 x 5-3/8")
Net weight	1.0 - 1.3 kg (2.2 - 2.9 lbs.)

40Vmax XGT

12

Strap Hook. Battery and Charger are sold separately

**DML808** 18V, 14.4V Cordless LED Flashlight

18V / 14.4V LXT Li-Ion LED Flashlight, 190 Lumens

Li-ion Ah 6.0 5.0 3.0 1.5



Run Time (hrs)	Up to: 32
Luminous Flux	190 lm
Illuminance	at 1m from the light source 170 - 4,500 lx with BL1815N / BL1820B: 280x79x101 mm (11"x3- 1/8"x4") with BL1830B / BL1840B / BL1850B / BL1860B: 297x79x119 mm (11-3/4"x3- 1/8"x4-11/16")
Dimensions (L x W x H)	
Net weight	0.73 - 1.09 kg (1.6 - 2.4 lbs)

18V 14.4V LXT 1

Strap Hook. Battery and Charger are sold separately

**DML815** 18V, 14.4V Cordless LED Flashlight

18V / 14.4V LXT Li-Ion LED Flashlight, 160 Lumens

Li-ion Ah 6.0 5.0 3.0 1.5



Run Time (hrs)	Up to: 54
Luminous Flux	160 lm
Illuminance	at 1m from the light source: 3,000 lx
Dimensions (L x W x H)	w/ BL1830B / BL1850B / BL1860B: 272x79x116 mm (10-3/4"x3-1/8"x4-9/16")
Net weight	0.26 - 0.93 kg (0.57 - 2.05 lbs.)

18V 14.4V 5

Strap Hook. Battery and Charger are sold separately

**ML105** Cordless LED Worklight

High-luminance single LED flashlight provides 190 lumens

Li-ion Ah 4.0 2.0 1.5



Run Time (hrs)	Up to: 14
Luminous Flux	190 lm
Luminous	at 1m from the light source: 5,500 lx w/ BL1016/BL1021B: 249 x 66 x 93 mm (9-3/4 x 2-5/8 x 3-5/8") w/ BL1041B: 268 x 66 x 93 mm (10-1/2 x 2-5/8 x 3-5/8")
Dimensions (L x W x H)	
Net weight	0.53 - 0.70 kg (1.2 - 1.5 lbs.)

12Vmax CXT 12

Strap Hook. Battery and Charger are sold separately

**ML106** Cordless Flashlight

Multifaceted Reflector Illuminates Evenly for Increased Visibility

Li-ion Ah 4.0 2.0 1.5



Run Time (hrs)	Up to: 12
Luminous Flux	190 lm
Luminous	at 1m from the light source: 170 - 4,500 lx w/ BL1016/BL1021B: 271 x 66 x 93 mm (10-5/8 x 2-5/8 x 3-5/8") w/ BL1041B: 290 x 66 x 93 mm (11-3/8 x 2-5/8 x 3-5/8")
Dimensions (L x W x H)	
Net weight	0.61 - 0.78 kg (1.3 - 1.7 lbs.)

12Vmax CXT 8

Strap Hook. Battery and Charger are sold separately

**DML185** 18V Rechargeable Flashlight

High-luminance single flashlight provides 180 lumens

Li-ion Ah 6.0 5.0 3.0 1.5



Max Run Time (min)	550
Overall Length	284 mm (11-1/8")
Net weight	0.71 - 1.03 kg (1.6 - 2.3 lbs.)

18V LXT 1

Shoulder Strap, Bulb x2. Battery and Charger are sold separately



**ML002G Cordless LED Worklight**

40Vmax XGT Li-Ion 21 LED Worklight, 710 Lumens

Li-ion Ah 8.0 | 5.0 | 4.0 | 2.5 | 2.0



Run Time (hrs)	Up to: 51
Main light (on bar side)	Luminous flux (Full brightness): 710 lm Illuminance (Full brightness): 340 lx Luminous flux (Half brightness): 340 lm Illuminance (Half brightness): 310 lx
Sub light (on top side)	Luminous flux: 130 lm Illuminance: 1,900 lx
Dimensions (L x W x H)	w/ BL4025: 376 x 86 x 126 mm w/ BL4040: 382 x 86 x 141 mm
Net weight	1.2 - 1.5 kg (2.7 - 3.3 lbs.)

Length (with the hook stood), Illuminance: at 50 cm from the light source

40Vmax 6

Battery and Charger are sold separately



**DML806 / DML807 Cordless LED Flashlight**

18V / 14.4V LXT Li-Ion 21 LED Flashlight

Li-ion Ah 6.0 | 5.0 | 3.0 | 1.5



Run Time (hrs)	DML806 / DML807: Up to: 21 / 23
Main Light	Up to: 59 / 36
Sub Light	
Luminous Flux (Max)	DML806 / DML807: 620 lm / 710 lm
Dimensions (L x W x H)	DML806: 365 x 78 x 119 mm DML807: 414 x 79 x 155 mm
Net weight	DML806: 0.69 - 1.1 kg DML807: 0.72 - 1.1 kg

Length (with hook retracted), Overall length (with hook in upright position)

18V 14.4V 1

Battery and Charger are sold separately

**ML104 Cordless LED Worklight**

Optional magnet attachment for hands-free operation

Li-ion Ah 4.0 | 2.0 | 1.5



Run Time (hrs)	Up to: 19
Main light (on bar side)	Luminous flux (Full brightness): 710 lm Illuminance (Full brightness): 340 lx
Sub light (on top side)	Luminous flux: 130 lm Illuminance: 1,900 lx
Dimensions (L x W x H)	414 x 66 x 132 mm (16-1/4 x 2-5/8 x 5-3/16")
Net weight	0.61 - 0.78 kg (1.4 - 1.7 lbs.)

Length (with the hook stood), Illuminance: at 50 cm from the light source

12Vmax 8

Battery and Charger are sold separately

**ML006G Cordless Flashlight**

New

40Vmax XGT Li-Ion Flashlight Provides 500 Lumens

Li-ion Ah 8.0 | 5.0 | 4.0 | 2.5 | 2.0



Run Time (hrs)	Up to: 82 (Low mode, with BL4040)
Illuminance (at 0.5m from the light source)	High / Medium / Low: 800 / 400 / 180 lx
Luminous Flux	High / Medium / Low: 500 / 250 / 100 lm
Dimensions (L x W x H)	w/ BL4040: 275 - 408 x 85 x 148 mm (10-7/8 - 16 x 3-3/8 x 5-7/8")
Net weight	1.1 - 1.7 kg (2.4 - 3.8 lbs.)

40Vmax

Shoulder hook set, Lamp shade, Battery and Charger are sold separately

**DML816 Cordless Flashlight**

New

18V LXT Li-Ion Flashlight Provides 500 Lumens

Li-ion 6.0 | 5.0 | 3.0 | 1.5



Run Time (hrs)	Up to: 75 (Low mode, with BL1860B)
Illuminance (at 0.5m from the light source)	High / Medium / Low: 800 / 400 / 180 lx
Luminous Flux	High / Medium / Low: 500 / 250 / 100 lm
Dimensions (L x W x H)	w/ BL1830B / BL1850B / BL1860B: 267 - 400 x 79 x 127 mm (10-1/2 - 15-3/4 x 3-1/8 x 5")
Net weight	0.70 - 1.1 kg (1.5 - 2.4 lbs.)

18V 14.4V

Shoulder hook set, Lamp shade, Battery and Charger are sold separately

**DML801 LED Flashlight**

Extra Bright 12 LED Flashlight Provides 240 Lumens

Li-ion Ah 6.0 | 5.0 | 3.0 | 1.5



Run Time (hrs)	Up to: 48
Illuminance	at 1m from the light source
Luminous Flux	High: 400 lx, Low: 200 lx High: 240 lm, Low: 120 lm
Dimensions (L x W x H)	380 x 79 x 116 mm (15" x 9-11/16" x 4-9/16")
Net weight	0.61 - 0.98 kg (1.4 - 2.2 lbs)

Dimensions (L x W x H) : Head light section / 55x55x55mm (2-3/16"x2-3/16"x2-3/16").

18V 14.4V 1

Shoulder strap with metal hook. Battery and Charger are sold separately

**ML103 Cordless LED Worklight**

Compact size fits your hand perfectly

Li-ion Ah 4.0 | 2.0 | 1.5



Run Time (hrs)	Up to: 28
Dimensions (L x W x H)	w/o Battery: 77 x 54 x 28 mm (3 x 2-1/8 x 1-1/8") w/ BL1016/BL1021B: 87 x 64 x 54 mm (3-7/16 x 2-1/2 x 2-1/8") w/ BL1041B: 87 x 64 x 73 mm (3-7/16 x 2-1/2 x 2-7/8")
Net weight	0.27 - 0.43 kg (0.6 - 1.0 lbs.)

12Vmax 20

Battery and Charger are sold separately

# As a charger for smartphones, tablets and more



## Adapter for USB ADP001G 40V max

Strap hole

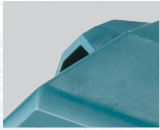

ON-OFF switch



Number of times iPhoneXR can be recharged on a single full battery charge

- BL4020 (2.0Ah): 2.8
- BL4025 (2.5Ah): 3.5
- BL4040 (4.0Ah): 5.6
- BL4050F (5.0Ah): 7.0

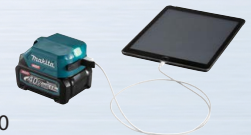

USB output port

- enables to charge two mobile devices at the same time
- Type A USB sockets for DC5V/ 2.1A (one port), 4.2A (two ports) USB output



## Adapter for USB ADP08 12V max



ON-OFF switch



Strap hole



USB output port

Type A USB port for DC5V/ 2.1A  
USB output



## Adapter for USB Series

ADP05 18V LXT



ADP06 12V max CXT



2 USB output ports with Caps provide 4.2A output for charging smart phones, tablets, etc.



Belt clip



Strap hole





PRODUCTS



# OPE TOOLS

### UX01GZ Cordless Multi Function Power Head

High power BL motor enables to work under heavy load

Li-ion Ah 8.0 | 5.0 | 4.0 | 2.5 | 2.0



No Load Speed (RPM) High: 0-9,700  
Medium: 0-8,200  
Low: 0-5,700  
Dimensions (L x W x H) 1,027 x 320 x 209 mm (40-1/2 x 12-5/8 x 8-1/4")  
Net weight 4.1 - 4.7 kg (9.3 - 10.6 lbs.)

40Vmax



XGT BL AFT WC XPT



Harness, Safety Goggles, Hex Wrench, Accessory Bag Z: Battery and Charger are sold separately

### DUX60Z Cordless Multi Function Power Head

Multi Function System

Li-ion Ah 6.0 | 5.0 | 3.0 | 1.5



No Load Speed (RPM) High: 0-9,700  
Medium: 0-8,200  
Low: 0-5,700  
Dimensions (L x W x H) 1,011 x 320 x 216 mm (39-3/4 x 12-5/8 x 8-1/2")  
Net weight 4.1 - 8.7 kg (8.9 - 19.2 lbs.)

18V x2



XGT BL AFT XPT



Harness, Safety Goggles, Hex Wrench, Accessory Bag Z: Battery and Charger are sold separately

## Cordless Multi Function Power Head

UX01G / DUX60 / DUX18



# BL MOTOR

## High Power BL Motor



High power BL motor allows for more comfortable operation in rather heavy-duty application using an attachment such as power brush, power sweep, blower, etc.



Reverse switch for easy removal of grass clippings from the cutting tool (UX01G / DUX60 only)

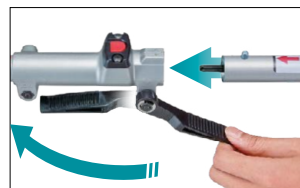

Easy Change



Excellent Mobility

## AFT Active Feedback sensing Technology

- If kickback occurs while using below attachment, brake works automatically:
  - 1) Brushcutter with metal blade attachment
  - 2) Pole saw attachment
- If the sensor detects drastically decrease of rotation, the motor stops immediately.

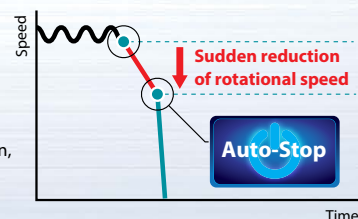



Optional attachments

UX01G / DUX60 / DUX18

Consisting of power head and versatile optional attachments are ideal for a wide range of applications

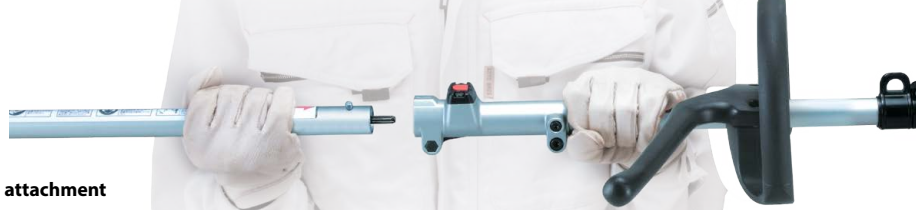

Rotary Scissors

EM407MP  
191M60-2



Shaft extension attachment

LE400MP  
191E23-0  
Length: 1,080mm (42-1/2")  
For Pole saw, Pole hedge trimmer and Coffee harvester

Coffee harvester

EJ400MP  
195726-8  
197163-2

Grass trimmer

EM408MP  
191N35-7  
EM409MP  
191N48-8



Ground trimmer

EN420MP  
198061-3



Pole saw

EY401MP  
199925-4



Cultivator

KR400MP / KR401MP  
195712-9 / 195716-1

Edger

EE400MP  
196750-4



Brushcutter

EM400MP / EM402MP  
195658-9 / 195952-9



Blower

UB400MP  
191F72-3  
UB401MP  
191P78-1  
UB402MP  
191250-7

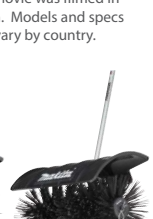

Power sweep attachment

SW400MP  
199344-4

Power brush attachment

BR400MP  
199323-2



This movie was filmed in Japan. Models and specs may vary by country.

String trimmer

ER400MP  
195530-5

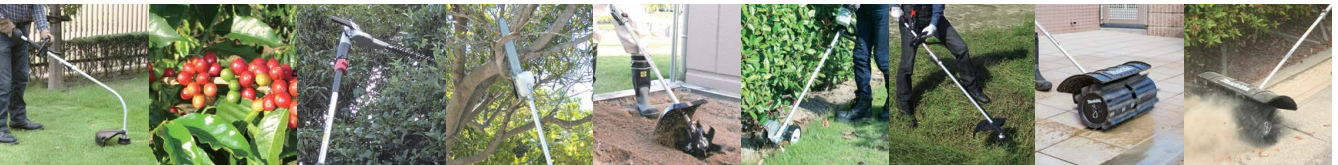

DUX18Z Cordless Multi Function Power Head

Multi Function System

Li-ion Ah 6.0 5.0 3.0 1.5



No Load Speed (RPM) High: 0-9,700  
Low: 0-6,800  
Dimensions (L x W x H) w/BL1830B / BL1850B / BL1860B: 977 x 318 x 175 mm (38-3/4 x 12-1/2 x 6-7/8")  
Net weight 2.8-10.3 kg (6.2-22.7 lbs.)

18V



LXT BL AFT XPT

1

Harness, Safety Goggles, Hex Wrench, Accessory Bag Z: Battery and Charger are sold separately

UC003GZ01 300mm (12") Cordless Chain Saw

New

40Vmax XGT BL Brushless Cordless 30 cm (12") Chain Saw

Li-ion Ah 8.0 5.0 4.0 2.5 2.0



Guide Bar Length 300 mm (12")  
Chain Pitch 3/8"  
Chain Gauge 1.1 mm (0.043")  
Chain Speed 0-24.8 m/s (0-1,490 m/min) (0-4,880 FPM)  
Chain Oil Tank Volume 200 mL (6.8 US oz) w/o Guide Bar  
Dimensions (L x W x H) :266 x 194 x 227 mm (10-1/2 x 7-5/8 x 8-15/16")  
Net weight 3.9-4.5 kg (8.6-9.9 lbs.)

40Vmax



XGT BL WG

1

Saw Chain, Guide Bar, Guide Bar Cover, Oil supply (country-specific), Round File (country-specific), Box Wrench, Battery, Charger Z: Battery and Charger are sold separately



WG / IPX4 WET GUARD



Photo: UC003G  
Hanging D-ring Rope attachment point

Cutting work amount  
Work volume on a single full battery charge

About **160** cuts

- 100x100mm cedar timber
- Guide bar/ Saw chain: 350mm/ 90PX
- Battery : BL4040

Net weight **2.6** kg Tool only

Max Chain Speed **24.8** m/s



Captive nuts prevent loss of nut



Variable speed trigger switch



Large oil tank cap allows for easy chain oil filling.



Chain tensioning screw

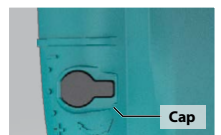

Adjustable automatic chain lubrication

Metal spike bar Chain oil level window

Metal chain catcher

## UC012GT101(RT) / GZ 400mm (16") Cordless Chain Saw

New

40Vmax XGT BL Brushless Cordless Chain Saw

Li-ion Ah 8.0 | 5.0 | 4.0 | 2.5 | 2.0



Guide Bar Length	400 mm (16")
Chain Pitch	3/8"
Chain Gauge	1.1 mm (0.043")
Chain Speed	0 - 24.7 m/s (0 - 1,482 m/min) (0 - 4,862 FPM)
Chain Oil Tank Volume	230 mL (7.8 US oz)
Dimensions (L x W x H)	446 x 233 x 274 mm (17-1/2 x 9-1/8 x 10-3/4")
Net weight	6.0 - 6.5 kg (13.2 - 14.4 lbs.)

40Vmax



XGT BL WGT



Saw Chain, Guide Bar, Guide Bar Cover, Oil supply (country-specific), Round File (country-specific), Box Wrench, Battery, Charger Z: Battery and Charger are sold separately

UC015GT101(RT) / GZ 350mm (14") Cordless Chain Saw  
UC014GT101(RT) / GZ 300mm (12") Cordless Chain Saw

New

40Vmax XGT BL Brushless Cordless Chain Saw

Li-ion Ah 8.0 | 5.0 | 4.0 | 2.5 | 2.0



Guide Bar Length	UC015G: 350 mm (14") UC014G: 300 mm (12")
Chain Pitch	3/8"
Chain Gauge	1.1 mm (0.043")
Chain Speed	0 - 24.7 m/s (0 - 1,482 m/min) (0 - 4,862 FPM)
Chain Oil Tank Volume	230 mL (7.8 US oz)
Dimensions (L x W x H)	w/o Guide Bar : 446 x 233 x 274 mm (17-1/2 x 9-1/8 x 10-3/4")
Net weight	6.0 - 6.5 kg (13.2 - 14.4 lbs.)

40Vmax



XGT BL WGT



Saw Chain, Guide Bar, Guide Bar Cover, Oil supply (country-specific), Round File (country-specific), Box Wrench, Battery, Charger Z: Battery and Charger are sold separately

## DUC353ZB 350mm (14") Cordless Chain Saw

High efficiency equivalent to 30mL class engine chain saws

Li-ion Ah 6.0 | 5.0 | 3.0 | 1.5



Guide Bar Length	350 mm (14")
Chain Pitch /	9.5 mm (3/8") /
Chain Gauge	1.1 / 1.3 mm (.043" / .050")
Chain Speed	0 - 20 m/s (0 - 1,200 m/min)
Chain Oil Tank Volume	200 mL
Sound Power Level	98.7 dB(A)
Dimensions (L x W x H)	762 x 215 x 235 mm (30" x 8-5/16" x 9-1/4")
Net weight	4.7 kg - 5.4 kg (10.4 lbs - 11.8 lbs)

18V x2



LXT BL XPT



Saw Chain, Guide Bar, Guide Bar Cover, Chain oil 100mL. Z: Battery and Charger are sold separately

## DUC355Z 350mm (14") Cordless Chain Saw

High efficiency equivalent to 30mL class engine chain saws

Li-ion Ah 6.0 | 5.0 | 3.0 | 1.5



Guide Bar Length	350 mm (14")
Chain Pitch /	9.5 mm (3/8") /
Chain Gauge	1.1 / 1.3 mm (.043" / .050")
Chain Speed	0 - 20 m/s (0 - 1,200 m/min)
Chain Oil Tank Volume	200 mL
Sound Power Level	98.7 dB(A)
Dimensions (L x W x H)	762 x 215 x 235 mm (30" x 8-5/16" x 9-1/4")
Net weight	4.7 kg - 5.4 kg (10.4 lbs - 11.8 lbs)

18V x2



LXT BL XPT



Saw Chain, Guide Bar, Guide Bar Cover, Chain oil 100mL, Wrench Z: Battery and Charger are sold separately

## DUC306ZB 300mm (12") Cordless Chain Saw

High efficiency equivalent to 30mL class engine chain saws

Li-ion Ah 6.0 | 5.0 | 3.0 | 1.5



Guide Bar Length	300 mm (12")
Chain Pitch /	9.5 mm (3/8") / 1.1 or 1.3 mm (0.043" or 0.050")
Chain Gauge	1.1 mm (0.043")
Chain Speed	0 - 20 m/s (0 - 1,200 m/min) (0 - 3,940 FPM)
Chain Oil Tank Volume	200 mL (6.8 US oz)
Sound Power Level	103 dB(A)
Dimensions (L x W x H)	270-651 x 205 x 232 mm (10-5/8" - 25-5/8" x 8-1/8" x 9-1/8")
Net weight	4.6 - 5.1 kg (10.1 - 11.1 lbs.)

18V x2



LXT BL XPT



Saw Chain, Guide Bar, Guide Bar Cover, Chain oil 100mL, Wrench Z: Battery and Charger are sold separately

## DUC302Z 300mm (12") Cordless Chain Saw

Cordless chain saws powered by two 18V Li-ion batteries in series

441

Li-ion Ah 6.0 | 5.0 | 3.0 | 1.5



Guide Bar Length	300 mm (12")
Chain Pitch /	9.5 mm (3/8")
Chain Gauge	1.1 mm (0.043")
Chain Speed	8.3 m/s (500 m/min) (1,650 FPM)
Chain Oil Tank Volume	85 mL (2.9 US oz)
Sound Power Level	95.4 dB(A)
Dimensions (L x W x H)	600 x 234 x 198 mm (23-5/8" x 9-1/4" x 7-3/4")
Net weight	4.1 kg (9.0 lbs)

18V x2



LXT BL XPT



Guide Bar Cover, Oil Supply, File, Z: Battery and Charger are sold separately

## DUC357ZX4 350mm (14") Cordless Chain Saw

New

Consistently powerful cutting action

Li-ion Ah 6.0 | 5.0 | 3.0 | 1.5



Guide Bar Length	350 mm (14")
Chain Pitch /	3/8" / 1.1 mm (0.043") or
Chain Gauge	1.3 mm (0.050")
Chain Speed	7.7 m/s
Chain Oil Tank Volume	150 mL (5.1 US oz)
Sound Power Level	97 dB(A)
Dimensions (L x W x H)	762 x 214 x 234 mm (30 x 8-3/8 x 9-1/4")
Net weight	4.2 - 4.4 kg (9.3 - 9.7 lbs.)

18V



LXT BL XPT



Saw chain, Guide bar, Guide bar case, Round file (country-specific), Chain oil (country-specific), Battery, Charger, Z: Battery and Charger are sold separately

## DUC254Z 250mm (10") Cordless Chain Saw

Efficiency equivalent to 23mL class engine chain saw

Li-ion Ah 6.0 | 5.0 | 3.0 | 1.5



Guide Bar Length	250 mm (10")
Chain Pitch /	3/8" / 1.1 mm (0.043")
Chain Gauge	3/8" / 1.3 mm (0.050")
Chain Speed	0 - 24 m/s (0 - 1,440 m/min) (0 - 4,720 FPM)
Chain Oil Tank Volume	140 mL
Sound Power Level	103.2 dB(A)
Dimensions (L x W x H)	w/o Guide Bar: 258 x 184 x 191 mm w/ 25 cm (10") 90PX Sprocket Nose Bar: 482 x 184 x 191 mm
Net weight	2.8 - 3.2 kg (6.2 - 6.9 lbs.)

18V



LXT BL XPT



Saw Chain, Guide Bar, Guide Bar Cover, Wrench, Accessory Bag Z: Battery and Charger are sold separately



**UC3541A 350mm (14") / UC4041A 400mm (16") Chain Saw**

Excellent in heavy duty application

153



Continuous Rating Input	1,800W
Chain Speed Per Minute	870m (2,900ft)
Saw Chain Pitch	3/8" / 1.1mm (.043")
Saw Chain Gauge	1.3mm (.050")
Sound Power Level	101.3dB(A)
Dimensions (L x W x H)	455x245x200mm
Net Weight	4.7kg (10.3lbs)

Dimensions: excluding blade and guide bar



Chain Blade, Guide Bar Cover, Hook Complete

**UC3551A 350mm (14") / UC4051A 400mm (16") Chain Saw**

Large trigger switch with soft start for smooth start-ups

153



Continuous Rating Input	2,000W
Chain Speed Per Minute	870m (2,900ft)
Guide Bar Length	UC3551A: 350mm (14")
Saw Chain Pitch	3/8"
Saw Chain Gauge	1.3mm (.050")
Sound Power Level	101.8dB(A)
Dimensions (L x W x H)	505x200x220mm (19-7/8"x7-7/8"x8-5/8")
Net Weight	5.5kg (12.1lbs)
Power Supply Cord	0.3m (0.98ft)

Dimensions: excluding blade and guide bar



Chain Blade, Guide Bar Cover, Hook Complete

**UC4551A 450mm (18") Electric Chain Saw**

Heavy-duty for fast and efficient cutting

153



Continuous rating input	2,000W
Chain speed per minute	870 m (2,900 ft)
Guide Bar Length	450 mm (18")
Saw chain	Pitch: 3/8" Gauge: 1.3 mm (0.050")
Sound Power Level	101.8 dB(A)
Dimensions (L x W x H)	505x200x220 mm (19-7/8"x7-7/8"x8-5/8")
Net weight	5.7 kg (12.4 lbs.)
Power supply cord	0.3 m (0.98 ft)

Dimensions: excluding blade and guide bar



Saw Chain, Guide Bar Cover, Hook complete

**UA001GM102(RM) / GZ01 250mm (10") Cordless Pole Saw**

**New**

40Vmax XGT BL AFT 25 cm (10") Cordless Pole Saw

Li-ion Ah 8.0 | 5.0 | 4.0 | 2.5 | 2.0



Guide Bar Length	250 mm (10")
Saw chain	Gauge: 1.1 - 1.3 mm (0.043 - 0.050") Pitch: 3/8"
Chain Speed	0 - 20 m/s (0 - 1,200 m/min) (0 - 3,940 FPM)
Oil Tank Capacity	160 mL
Dimensions (L x W x H)	w/o Guide Bar: 2,228 x 157 x 189 mm (87-3/4 x 6-3/16 x 7-7/16")
Net weight	6.0 - 7.3 kg (13.2 - 16.1 lbs.)



Saw Chain, Guide Bar, Guide Bar Case, Wrench, Band Assembly, Battery, Charger, Round File (country-specific), File (country-specific), Chain Oil (country-specific), Z: Battery and Charger are sold separately



**UA002GM102(RM) / GZ01 250mm (10") Cordless Telescopic Pole Saw**

**New**

40Vmax XGT BL AFT 25 cm (10") Cordless Telescopic Pole Saw

Li-ion Ah 8.0 | 5.0 | 4.0 | 2.5 | 2.0



Guide Bar Length	250 mm (10")
Saw chain	Gauge: 1.1 - 1.3 mm (0.043 - 0.050") Pitch: 3/8"
Chain Speed	0 - 20 m/s (0 - 1,200 m/min) (0 - 3,940 FPM)
Oil Tank Capacity	160 mL
Dimensions (L x W x H)	w/o Guide Bar: 2,515 - 3,747 x 157 x 191 mm (99 - 147-1/2 x 6-3/16 x 7-1/2")
Net weight	7.6 - 8.9 kg (16.8 - 19.6 lbs.)



Saw Chain, Guide Bar, Guide Bar Case, Wrench, Hex Wrench, Band Assembly, Battery, Charger, Round File (country-specific), File (country-specific), Chain Oil (country-specific), Z: Battery and Charger are sold separately

**DUA300ZB 300mm (12") Cordless Pole Saw**

High cutting efficiency

Li-ion Ah 6.0 | 5.0 | 3.0 | 1.5



Guide Bar Length	300 mm (12")
Saw chain	Gauge: 1.1 / 1.3 mm (0.043 / 0.050") Pitch: 3/8"
Chain Speed	0 - 20.0 m/s (0 - 1,200 m/min) (0 - 3,940 FPM)
Oil Tank Capacity	160 mL
Dimensions (L x W x H)	2,238 x 155 x 191 mm (88 x 6-1/8 x 7-1/2")
Net weight	6.1 - 6.9 kg



Saw Chain, Guide Bar, Blade Cover, Wrench, Band Assembly, Hex Wrench, Battery, Charger, Z: Battery and Charger are sold separately

**DUA301ZB 300mm (12") Cordless Telescopic Pole Saw**

High cutting efficiency

Li-ion Ah 6.0 | 5.0 | 3.0 | 1.5



Guide Bar Length	300 mm (12")
Saw chain	Gauge: 1.1 / 1.3 mm (0.043 / 0.050") Pitch: 3/8"
Chain Speed	0 - 20.0 m/s (0 - 1,200 m/min) (0 - 3,940 FPM)
Oil Tank Capacity	160 mL
Dimensions (L x W x H)	2,554 - 3,789 x 155 x 193 mm (100-1/2"-149"x 6-1/8"x 7-5/8")
Net weight	7.8 - 8.5 kg



Saw Chain, Guide Bar, Blade Cover, Wrench, Band Assembly, Hex Wrench, Battery, Charger, Z: Battery and Charger are sold separately



**DCU180Z Battery Powered Wheelbarrow**

Moving cart powered by one or two LXT Li-ion batteries

Li-ion Ah 6.0 | 5.0 | 3.0 | 1.5



Max Run Time (min)	with BL1860B: 120
Max Load Capacity	130 kg (290 lbs.)
Traveling Speed	Forward, High / Low: 0 - 3.5 / 0 - 1.5 km/h Reverse: 0 - 1 km/h
Max Climbing Capacity	12°
Dimensions (L x W x H)	When carrier is installed / During operation: 1,315x1,060x900 mm (51-3/4"x41-3/4"x35-1/2")
Net weight	39.3 - 44.8 kg (86.5 - 98.7 lbs)

18V



Lock Key, Support Legs, Wrenches, Z: Battery and Charger are sold separately

**UH014GM101 (RM) / GZ 750mm (29-1/2") Cordless Hedge Trimmer**

New

40Vmax XGT BL Brushless Cordless 75 cm (29-1/2") Hedge Trimmer

Li-ion Ah 8.0 | 5.0 | 4.0 | 2.5 | 2.0



Blade Length	750 mm (29-1/2")
Max Cutting Capacity	18 mm (11/16")
Strokes Per Minute (SPM)	High / Mid / Low: 5,000 / 3,600 / 2,000
Dimensions (L x W x H)	w/o Battery: 1,225 x 270 x 135 mm w/BL4020 / BL4025: 1,225 x 270 x 135 mm w/BL4040: 1,225 x 270 x 150 mm w/BL4050F: 1,225 x 270 x 168 mm
Net weight	4.0 - 4.7 kg (8.8 - 10.4 lbs.)

40Vmax



Blade Cover, Safety Goggles (country-specific), Chip Receiver, Battery, Charger, Z: Battery and Charger are sold separately

**UH006GZ 600mm (23-5/8") Cordless Hedge Trimmer**

Reliable cutting performance like engine/AC hedge trimmers

Li-ion Ah 8.0 | 5.0 | 4.0 | 2.5 | 2.0



Blade Length	600 mm (23-5/8")
Max Cutting Capacity	25.0 mm (1")
Strokes Per Minute (SPM)	High / Mid / Low: 4,000 / 3,000 / 2,000
Sound Pressure Level	81 dB(A)
Sound Power Level	92 dB(A)
Vibration Level	Front / Rear: 3.0 / 2.5 m/s <sup>2</sup> or less
Dimensions (L x W x H)	w/BL4020 / BL4025: 1,123 x 223 x 191 mm (44-1/4" x 8-3/4" x 7-1/2")
Net weight	4.4 - 5.0 kg (9.7 - 11.0 lbs.)

40Vmax



Blade Cover, Safety goggles (country-specific), Chip Receiver, Battery, Charger, Z: Battery and Charger are sold separately

**DUH606Z 600mm (23-5/8") Cordless Hedge Trimmer**

New

18V LXT BL Brushless Cordless 60 cm (23-5/8") Hedge Trimmer

Li-ion Ah 6.0 | 5.0 | 3.0 | 1.5



Blade Length	600 mm (23-5/8")
Tooth Spacing	30 mm (1-3/16")
Strokes Per Minute (SPM)	4,000
Max Output	320 W
Dimensions (L x W x H)	1,015 x 207 x 185 mm (40x8-1/8"x7-1/4")
Net weight	3.1 kg (6.8 lbs.)

18V



Blade Cover, Battery, Charger, Z: Battery and Charger are sold separately

**Cordless Hedge Trimmer**

UH014G

Same level performance as petrol hedge trimmer.



**Easy-to-use Front handle**

Redesigned the gripping position of Front handle and place the center of gravity on the line connecting Front handle and Rear handle to reduce the force applied in the direction of twisting the wrist.

Due to the inclination of Front handle end, it can be gripped when cutting the top surface, the angle at which the wrist is returned can be reduced, and wrist fatigue is reduced.



Twigs are caught easily and held firmly



Cutting strokes per minute  
**5,000 min<sup>-1</sup>**  
High speed mode

Low noise  
**92 dB (A)**

Maximum branch diameter  
Maximum cutting diameter:  
**23.5 mm**  
18mm

**DUH754SZ 750mm (29-1/2") Cordless Hedge Trimmer**

18V LXT BL Brushless Cordless 75 cm (29-1/2") Hedge Trimmer

Li-ion Ah 6.0 | 5.0 | 3.0 | 1.5



Blade Length	750 mm (29-1/2")
Max Cutting Capacity	23.5 mm (15/16")
Sound Pressure Level	80.6 dB(A)
Sound power level	91.6 dB (A)
Vibration Level	2.5 m/s <sup>2</sup> or less
Strokes Per Minute (SPM)	High / Med / Low: 0 - 4,400 / 0 - 3,600 / 0 - 2,000
Dimensions (L x W x H)	1,198x280x147 mm (47-1/4"x11"x5-3/4")
Net weight	4.1 kg (9.0 lbs.)

18V



Blade Cover, Safety Goggles (country-specific), Chip Receiver (country-specific), Battery, Charger, Z: Battery and Charger are sold separately

**DUH604SZ 600mm (23-5/8") Cordless Hedge Trimmer**

18V LXT BL Brushless Cordless 60 cm (23-5/8") Hedge Trimmer

Li-ion Ah 6.0 | 5.0 | 3.0 | 1.5



Blade Length	600 mm (23-5/8")
Max Cutting Capacity	23.5 mm (15/16")
Sound Pressure Level	79.3 dB(A)
Sound power level	90.3 dB (A)
Vibration Level	2.5 m/s <sup>2</sup> or less
Strokes Per Minute (SPM)	High / Med / Low: 0 - 4,400 / 0 - 3,600 / 0 - 2,000
Dimensions (L x W x H)	1,057x280x147 mm (41-1/2"x11"x5-3/4")
Net weight	4.0 kg (8.8 lbs.)

18V



Blade Cover, Safety Goggles (country-specific), Chip Receiver (country-specific), Battery, Charger, Z: Battery and Charger are sold separately

**DUH751Z 750mm (29-1/2") Cordless Hedge Trimmer**

18V LXT BL Brushless Cordless 75 cm (29-1/2") Hedge Trimmer

Li-ion Ah 6.0 5.0 3.0 1.5

Blade Length	750 mm (29-1/2")
Strokes Per Minute (SPM)	High / Med / Low: 0 - 4,400 / 0 - 3,600 / 0 - 2,000
Vibration Level	2.5 m/s <sup>2</sup>
Sound Power Level	97 dB(A)
Dimensions (L x W x H)	1,261 x 225 x 192 mm (49-1/2" x 8-7/8" x 7-1/2")
Net weight	3.8 - 4.5 kg (8.4 - 9.8 lbs.)



18V



LXT BL XPT 1

Blade Cover, Safety Goggles (country-specific), Chip Receiver (country-specific), Battery, Charger, Z: Battery and Charger are sold separately

**DUH601Z 600mm (23-5/8") Cordless Hedge Trimmer**

18V LXT BL Brushless Cordless 60 cm (23-5/8") Hedge Trimmer

Li-ion Ah 6.0 5.0 3.0 1.5

Blade Length	600 mm (23-5/8")
Strokes Per Minute (SPM)	High / Med / Low: 0 - 4,400 / 0 - 3,600 / 0 - 2,000
Vibration Level	2.5 m/s <sup>2</sup> or less
Sound Power Level	95 dB(A)
Dimensions (L x W x H)	1,121 x 225 x 192 mm (44-1/4" x 8-7/8" x 7-1/2")
Net weight	3.8 - 4.5 kg (8.4 - 9.8 lbs.)



18V



LXT BL XPT 1

Blade Cover, Safety Goggles (country-specific), Chip Receiver, Battery, Charger, Z: Battery and Charger are sold separately

**DUH502Z 500mm (19-3/4") Cordless Hedge Trimmer**

18V LXT BL Brushless Cordless 50 cm (19-3/4") Hedge Trimmer

Li-ion Ah 6.0 5.0 3.0 1.5

Blade Length	500 mm (19-5/8")
Strokes Per Minute (SPM)	High / Med / Low: 0 - 4,400 / 0 - 3,600 / 0 - 2,000
Vibration Level	2.5 m/s <sup>2</sup>
Sound Power Level	86.8 dB(A)
Dimensions (L x W x H)	1,016 x 225 x 192 mm (40" x 8-7/8" x 7-1/2")
Net weight	3.7 - 4.4 kg (8.2 - 9.7 lbs.)



18V



LXT BL XPT 1

Blade Cover, Safety Goggles (country-specific), Battery, Charger, Z: Battery and Charger are sold separately

**DUH651Z 650mm (25-1/2") Cordless Hedge Trimmer**

High maneuverability and environmentally-friendly

442

Li-ion Ah 6.0 5.0 3.0 1.5

Blade length	650mm (25-1/2")
Strokes Per Minute (SPM)	2,000-3,600
Sound Power Level	91.1 dB(A)
Dimensions (L x W x H)	1,135 x 225 x 200mm (44-3/4" x 8-7/8" x 7-8")
Max Output	0.32kW
Net weight	4.7 - 5.5 kg (10.3 - 12 lbs.)



18V x2



LXT XPT 1

Charger, Battery, Blade Cover, Z: Battery and Charger are sold separately

**DUH506Z 500mm (19-3/4") Cordless Hedge Trimmer**

**New**

18V LXT BL Brushless Cordless 50 cm (19-3/4") Hedge Trimmer

Li-ion Ah 6.0 5.0 3.0 1.5

Blade Length	500 mm (19-5/8")
Tooth Spacing	30 mm (1-3/16")
Strokes Per Minute (SPM)	4,000
Max Output	320 W
Dimensions (L x W x H)	896 x 207 x 185 mm (35-1/4" x 8-1/8" x 7-1/4")
Net weight	3.0 kg (6.6 lbs.)



18V



1

Blade Cover, Battery, Charger, Z: Battery and Charger are sold separately

**DUH523RF / SF / Z 520mm (20-1/2") Cordless Hedge Trimmer**

User-replaceable blade

Li-ion Ah 6.0 5.0 3.0 1.5

Blade length	520mm (20-1/2")
Strokes Per Minute (SPM)	2,700
Tooth spacing	26mm (1")
Sound Power Level	84.3 dB(A)
Dimensions (L x W x H)	938 x 195 x 193mm (37" x 7-5/8" x 7-5/8")
Max Output	210W
Net weight	3 - 3.4kg (6.7 - 7.5lbs)



18V



1

Fast Charger, Battery Cartridge, Blade Cover, Z: Battery and Charger are sold separately

**UH353DSA / DWA / DZ 350mm (13-3/4") Cordless Hedge Trimmer**

Lightweight, Low Vibration, Low Noise

Li-ion Ah 4.0 2.0 1.5

Max Output Power	170W
Cycles Per Minute (cpm)	1,650
Strokes Per Minute (SPM)	3,300
Cutting width	350 mm (13-3/4")
Max Cutting Capacity	15mm (9/16)
Dimensions (L x W x H)	693 x 175 x 165mm (27-1/4" x 6-7/8" x 6-1/2")
Net weight	2 - 2.1 kg (4.3 - 4.7 lbs.)



12Vmax



2

Blade Cover, Battery, Charger, DZ: Battery and Charger are sold separately

**DUN600LZ 600mm (23-5/8") Cordless Pole Hedge Trimmer**

18V LXT BL Brushless Cordless Pole Hedge Trimmer

Li-ion Ah 6.0 5.0 3.0 1.5

Blade Length	600 mm (23-5/8")
Max Cutting Capacity	23.5 mm (15/16")
Sound Pressure Level	82.5 dB(A)
Sound Power Level	93.5 dB (A)
Vibration Level	
Left hand (Front grip / Handle)	3.8 m/s <sup>2</sup>
Right hand (Rear grip)	2.7 m/s <sup>2</sup>
Strokes Per Minute (SPM)	High / Med / Low: 4,400 / 3,600 / 2,000
Overall length	2,050 mm
Net weight	4.4 kg (9.7 lbs.)



18V



LXT BL XPT 1

Blade Cover, Harness, Battery, Charger, Z: Battery and Charger are sold separately

**DUN500WZ** 500mm (19-3/4") Cordless Pole Hedge Trimmer

18V LXT BL Brushless Cordless Pole Hedge Trimmer

Li-ion Ah 6.0 5.0 3.0 1.5



Blade Length	500 mm (19-3/4")
Max Cutting Capacity	23.5 mm (15/16")
Sound Pressure Level	81.5 dB(A)
Sound Power Level	92.5 dB (A)
Vibration Level	
Left hand (Front grip / Handle)	4.7 m/s2
Right hand (Rear grip)	2.5 m/s2 or less
Strokes Per Minute (SPM)	High / Med / Low: 4,400 / 3,600 / 2,000
Overall length	2,115 mm
Net weight	4.5 kg (9.9 lbs.)

18V



Blade Cover, Harness, Battery, Charger, Z: Battery and Charger are sold separately

**DUN461WSF / WZ**  
460mm (18-1/8") Cordless Pole Hedge Trimmer

Telescopic pipe for no need of stepladders

Li-ion Ah 6.0 5.0 3.0 1.5



Blade Length	460 mm (18-1/8")
Max Cutting Capacity	18 mm (11/16")
Strokes Per Minute (SPM)	3,600
Cycles Per Minute (CPM)	1,800
Continuous Use (min.)	w/ BL1830B: 60
Dimensions (L x W x H)	1,889 - 2,511 x 87 x 133 mm (74-1/2 - 99 x 3-7/16 x 5-1/4")
Net weight	w/ BL1860B: 3.4 kg (7.5 lbs.)

18V



Blade Cover, Chip Receiver (country-specific), Shear Blade (country-specific), Battery, Charger, Z: Battery and Charger are sold separately

**UN460WDWA / WDZ**  
460mm (18-1/8") Cordless Pole Hedge Trimmer

12Vmax LXT Cordless 46 cm (18-1/8") Pole Hedge Trimmer

Li-ion Ah 4.0 2.0 1.5



Blade Length	460 mm (18-1/8")
Max Cutting Capacity	18 mm (11/16")
Strokes Per Minute (SPM)	3,600
Cycles Per Minute (CPM)	1,800
Dimensions (L x W x H)	1,889 - 2,511 x 87 x 133 mm (74-1/2 x 99 x 3-7/16 x 5-1/4")
Net weight	3.0 kg (6.6 lbs.)

12Vmax



Blade Cover, Chip Receiver (country-specific), Shear Blade (country-specific), Battery, Charger, DZ: Battery and Charger are sold separately

**UH201DSAX / DWA / DZ**  
200mm (7-7/8") Cordless Hedge Trimmer

12V max CXT Li-ion Cordless 20 cm (7-7/8") Hedge Trimmer

Li-ion Ah 4.0 2.0 1.5



Blade Length	200 mm (7-7/8")
Strokes Per Minute (SPM)	2,500
Dimensions (L x W x H)	504 x 120 x 131 mm (19-7/8"x4-3/4"x5-1/8")
Net Weight	1.3 - 1.5 kg (2.8 - 3.3 lbs)

12Vmax



Base Frame, Blade Cover, Battery, Charger, DZ: Battery and Charger are sold separately

**DUM604SF / Z** 160mm (6-5/16") Cordless Grass Shear

18V LXT Li-Ion Cordless 16 cm (6-5/16") Grass Shear

Li-ion Ah 6.0 5.0 3.0 1.5



Cutting Width	160 mm (6-5/16")
Depth Adjustment	15, 20, 25 mm (9/16", 13/16", 1")
Strokes Per Minute (SPM)	2,500
Continuous Use (min.)	with BL1860B / BL1850B / BL1840B / BL1830B / BL1820B / BL1815N: 250 / 200 / 160 / 125 / 80 / 60
Dimensions (L x W x H)	337x177x131 mm (13-1/4"x7"x5-1/8")
Net weight	1.4 - 1.8 kg (3.2 - 4.0 lbs)

18V



Grass Receiver, Blade Cover, Z: Battery and Charger are sold separately

**DUM111SYX** 110mm Cordless Grass Shear

11 cm cutting width for optimum performance

Li-ion Ah 6.0 5.0 3.0 1.5



Cutting Width	110 mm
Strokes Per Minute (SPM)	2,500
Continuous Use (min.)	with BL1860B / BL1850B / BL1830B / BL1820B / BL1815N: - / - / - / 45
Dimensions (L x W x H)	333 x 120 x 131 mm
Net weight	1.4 - 1.7 kg (3.2 - 3.8 lbs.)

18V



Blade Cover, Battery, Charger, Z: Battery and Charger are sold separately

**Tool-less blade change system**

- Grass shear blade can be removed / installed without tool.
- Hedge trimmer blade can be removed / installed by using a coin to loosen / tighten two screws.





**UM600DSYEX / DWA / DZ**  
160mm (6-5/16") Cordless Grass Shear

12V max CXT Li-Ion Cordless 16 cm (6-5/16") Grass Shear

Li-ion Ah 4.0 2.0 1.5



Cutting Width 160 mm (6-5/16")  
Strokes Per Minute (SPM) 2,500  
Dimensions (L x W x H) 329x177x131 mm (13"x7"x5-1/8")  
Net Weight 1.3 - 1.5 kg (2.8 - 3.3 lbs)

12Vmax



Base Frame, Blade Cover, Battery, Charger, DZ: Battery and Charger are sold separately

**UR012GZ204** Cordless Grass Trimmer

**New**

80Vmax XGT BL ADT AFT Cordless 3-Speed Grass Trimmer, Bike Handle

Li-ion Ah 8.0 5.0 4.0 2.5 2.0



Cutting Width Metal Blade: 305 mm  
Chisel Blade: 225 mm  
Nylon Cutting Head: 480 mm  
Shredder Blade: 270 mm  
Plastic Blade: 305 mm  
No Load Speed (RPM) Metal Blade (3/2/1): 0 - 6,800 / 0 - 5,000 / 0 - 3,500  
Nylon Cutting Head (3/2/1): 0 - 5,000 / 0 - 4,200 / 0 - 3,500  
Plastic Blade (3/2/1): 0 - 6,800 / 0 - 5,000 / 0 - 3,500  
Spindle Size M10 x 1.25 LH  
Net weight 8.0 - 9.3 kg (17.6 - 20.5 lbs.)

40Vmax x2



1

Safety Goggles, Metal Blade / Nylon Cutting Head / Plastic Blade (country-specific), Blade Cover (for the product with metal blade), Accessory Bag, Hex Wrench, Box Wrench, Shoulder Belt, Battery, Charger, Z: Battery and Charger are sold separately

**UR008GM101(RM) / GZ01** Cordless Grass Trimmer

**New**

40Vmax XGT BL ADT AFT Cordless 3-Speed Grass Trimmer, Loop Handle

Li-ion Ah 8.0 5.0 4.0 2.5 2.0



Cutting Width Nylon Cutting Head: 430 mm (17")  
Plastic Blade: 305 mm (12")  
No Load Speed (RPM) Nylon Cutting Head (3/2/1): 0 - 5,000 / 0 - 4,600 / 0 - 4,000  
Plastic Blade (3/2/1): 0 - 6,000 / 0 - 4,600 / 0 - 4,000  
Spindle Size M10 x 1.25 LH  
Dimensions (L x W x H) w/o Cutting Tool, w/o Battery: 1,803 x 224 x 300 mm (71 x 8-7/8 x 11-3/4")  
Net weight 5.0 - 5.7 kg (11.0 - 12.6 lbs.)

40Vmax



1

Safety Goggles, Nylon Cutting Head, Accessory Bag, Hex Wrench, Battery, Charger, Z: Battery and Charger are sold separately

**UR003GZ** Cordless Grass Trimmer

**New**

40Vmax XGT BL ADT AFT Cordless 3-Speed Grass Trimmer, Loop Handle

Li-ion Ah 8.0 5.0 4.0 2.5 2.0



Cutting Width Metal Blade: 230 mm (9")  
TCT Saw Blade: 255 mm (10")  
Nylon Cutting Head: 350 mm (13-3/4")  
Plastic Blade: 255 mm (10")  
No Load Speed (RPM) High / Mid / Low: 0 - 6,500 / 5,300 / 3,500  
Spindle Size M10 x 1.25 LH  
Net weight 3.9 - 4.5 kg (8.6 - 9.8 lbs.)

40Vmax



1

Safety Goggles, Metal Blade / Nylon Cutting Head / Plastic Blade (country-specific), Blade Cover (for the product with metal blade), Accessory Bag, Hex Wrench, Box Driver, Shoulder Belt, Battery, Charger, Z: Battery and Charger are sold separately



**UR202CZ** Battery Powered Grass Trimmer

BL ADT AFT Battery Powered 3-Speed Grass Trimmer



Cutting Width NTrimmer Head: 430 mm (17")  
Plastic Blade: 255 mm (10")  
No Load Speed (RPM) High / Med / Low: 0 - 6,000 / 4,600 / 4,000  
Spindle Size M10 x 1.25 LH  
Dimensions (L x W x H) 1,748 x 227 x 301 mm (69"x8-15/16"x11-7/8")  
Net weight 4.6 kg (10.0 lbs.)

40Vmax



1

Safety Goggles, Metal Blade / Nylon Cutting Head / Plastic Blade (country-specific), Blade cover (for the product with metal blade), Accessory Bag, Hex Wrench, Box Driver, Shoulder Belt, Battery, Charger

**DUR369LZ** Cordless Grass Trimmer

18V X2 (36V) LXT BL ADT AFT Cordless 3-Speed Grass Trimmer

Li-ion Ah 6.0 5.0 3.0 1.5



Cutting Width Metal Blade: 255 mm (10")  
Trimmer Head: 430 mm (17")  
Plastic Blade: 305 mm (12")  
No Load Speed (RPM) High / Med / Low: 3,300 - 7,000 / 5,500 / 4,600  
Spindle Size M10 x 1.25 LH  
Dimensions (L x W x H) 1,846 x 400 x 269 mm (72-1/2"x15-3/4"x10-5/8")  
Net weight 5.8 - 6.4 kg (12.8 - 14.1 lbs.)

18V x2



1

Safety Goggles, Metal Blade / Nylon Cutting Head / Plastic Blade (country-specific), Blade cover (for the product with metal blade), Accessory Bag, Hex Wrench, Shoulder Belt, Battery, Charger

**DUR368LZ** Cordless Grass Trimmer

18V X2 (36V) LXT BL ADT AFT Cordless 3-Speed Grass Trimmer

Li-ion Ah 6.0 5.0 3.0 1.5



Cutting Width	Metal Blade: 255 mm (10") Trimmer Head: 350 mm (13-3/4") Plastic Blade: 255 mm (10")
No Load Speed (RPM)	High / Med / Low: 6,500 / 5,300 / 3,500
Spindle Size	M10 x 1.25 LH
Sound Power Level	4-Tooth Blade: 89.2 dB(A) Nylon Cutting Head: 89 dB(A)
Dimensions (L x W x H)	1,758 x 362 x 231 mm (69-1/4" x 14-1/4" x 9-1/8")
Net weight	3.9 - 4.5 kg (8.6 - 10.0 lbs.)

18V x2



Safety Goggles, Metal Blade / Nylon Cutting Head / Plastic Blade (country-specific), Blade cover (for the product with metal blade), Accessory Bag, Hex Wrench, Box Driver, Shoulder Belt, Battery, Charger

**DUR365UZ** 230mm (9") Cordless Grass Trimmer

Brushless Cordless 3-Speed Grass Trimmer, Bike Handle

Li-ion Ah 6.0 5.0 3.0 1.5



Cutting Width	Metal Blade: 230 mm (9") Trimmer Head: 350 mm (13-3/4") Plastic Blade: 255 mm (10")
No Load Speed (RPM)	High / Medium / Low: 6,500 / 5,300 / 3,500
Spindle Size	M10 x 1.25 LH
Max Output (W)	550
Sound Power Level	Metal Blade: 86 dB(A) Plastic Blade: 92.8 dB(A) Nylon Cutting Head: 90 dB(A)
Dimensions (L x W x H)	1,754 x 610 x 460 mm (69" x 24" x 18-1/8")
Max Run Time (min)	With BL 1850B: 490
Net weight	4.7 kg (10.5 lbs)

18V x2

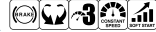

Safety Goggles, Metal Blade / Nylon Cutting Head / Plastic Blade, Blade cover (for the product with metal blade), Accessory Bag, Hex Wrench, Box Driver, Shoulder Belt Z: Battery and Charger are sold separately

**DUR190LZX3** Cordless Grass Trimmer

One protector for metal blade / plastic blade / trimmer head

Li-ion Ah 6.0 5.0 3.0 1.5



Cutting Width	Nylon Cutting Head: 300 mm (11-3/4") Metal Blade: 230 mm (9") Plastic Blade: 255 mm (10")
No Load Speed (RPM)	3,500 - 6,000
Spindle Size	M10 x 1.25 LH
Dimensions (L x W x H)	1,836 x 348 x 236 mm (72-1/4" x 13-3/4" x 9-1/4")
Net weight	2.9 - 3.2 kg (6.4 - 7.1 lbs.)

18V



Safety Goggles, Band Assembly, Tipped Saw, Accessory Bag, Box Driver, Hex Wrench, Cap, Tool Cover, Battery, Z: Battery and Charger are sold separately

**DUR189Z** Cordless Grass Trimmer

New

18V LXT BL ADT Cordless Grass Trimmer, Short Telescopic Pipe, Loop Handle

Li-ion Ah 6.0 5.0 3.0 1.5



Cutting Width	Trimmer Head: 300 mm (11-3/4") Plastic Blade: 255 mm (10")
No Load Speed (RPM)	High / Mid / Low / ADT Mode: 6,000 / 5,000 / 4,000 / 4,000 - 6,000
Spindle Size	M8 x 1.25 RH
Max Run Time (min)	Nylon Cutting Head, BL1860B: 168 Plastic Blade, BL1860B: 219
Net weight	3 - 3.3 kg (6.6 - 7.3 lbs.)

18V



Shoulder Strap, Nylon Cutting Head, Plastic Blade, Safety Goggles, Accessory Bag, Hex Wrench, Battery, Charger, Z: Battery and Charger are sold separately

**DUR194SFX2 / ZX3** Cordless Grass Trimmer

New

18V LXT Li-Ion Cordless 2-Speed Grass Trimmer, Loop Handle

Li-ion Ah 6.0 5.0 3.0 1.5



Cutting Width	Metal Blade: 200 mm (7-7/8") Trimmer Head: 280 mm (11") Plastic Blade: 230 mm (9")
No Load Speed (RPM)	High / Low: 6,000 / 4,500
Spindle Size	M10 x 1.25 LH
Dimensions (L x W x H)	1,630 x 288 x 236 mm (64 x 11-3/8 x 9-1/4")
Net weight	2.6 - 2.9 kg (5.7 - 6.4 lbs.)

18V



Safety Goggles (country-specific), Shoulder Belt, Nylon Cutting Head, Metal Blade / Nylon Cutting Head / Plastic Blade (country-specific), Hex Wrench, Box Driver, Accessory Bag, Battery, Charger, Z: Battery and Charger are sold separately

**DUR193SF / Z** Cordless Grass Trimmer

New

18V LXT Li-Ion Cordless Grass Trimmer

Li-ion Ah 6.0 5.0 3.0 1.5



Cutting Width	Trimmer Head: 260 mm (10-1/4")
No Load Speed (RPM)	7,800
Max Run Time (min)	w/ BL1830B: 45
Dimensions (L x W x H)	1,194 - 1,384 x 271 x 372 mm (47 - 54-1/2 x 10-5/8 x 14-5/8")
Net weight	2.4 - 2.7 kg (5.3 - 6.0 lbs.)

18V



Safety Goggles (country-specific), Shoulder Belt, Nylon Cutting Head, Metal Blade / Nylon Cutting Head / Plastic Blade (country-specific), Hex Wrench, Box Driver, Accessory Bag, Battery, Charger, Z: Battery and Charger are sold separately

**DUR181RF / SF / Z** Cordless String Trimmer

18V LXT Li-Ion Cordless String Trimmer

Li-ion Ah 6.0 5.0 3.0 1.5



Cutting Width	Trimmer Head: 260 mm (10-1/4")
No Load Speed (RPM)	7,800
Sound Power Level	88.5 dB(A)
Dimensions (L x W x H)	1,229 - 1,433 x 267 x 186 - 257 mm (48-1/2 - 56-1/2" x 10-1/2" x 7-3/8 - 10-1/8")
Max Run Time (min)	with BL1830B: 45
Net weight	2.8 - 3.1 kg (6.2 - 6.9 lbs)

18V



Safety Goggles, Shoulder Belt, Nylon Cutting Head, Nylon Cord, Battery, Fast Charger  
Z: Battery and Charger are sold separately

**UR100DWA / DZ** Cordless Grass Trimmer

Compact size is ideal for trimming and precise edging

Li-ion Ah 4.0 2.0 1.5



Cutting Width	Nylon Cutting Head: 260 mm (10") Plastic Blade: 230 mm (9")
No Load Speed (RPM)	10,000
Spindle Size	M8 x 1.25 RH
Dimensions (L x W x H)	835-1,195 x 267 x 210-315 mm
Net weight	1.9 - 2.1 kg (4.3 - 4.6 lbs.)

12Vmax



Safety Goggles, Shoulder Belt, Nylon Cutting Head, Nylon Cord, Plastic Blade, Accessory Bag, Hex Wrench, Battery, Charger, DZ: Battery and Charger are sold separately

**UR3000** 300mm (11-3/4") String Trimmer

Lightweight AC string trimmers for do-it-yourselfers



Continuous Rating Input	450W
Cutting Width	300 mm (11-3/4")
No Load Speed (RPM)	9,000
Sound Power Level	96 dB(A)
Dimensions (L x W x H)	1,016~1,256x301x262mm
Net Weight	2.6kg (5.7lbs)
Power Supply Cord	0.3m (1ft)



Extension Cord with Lock, Shoulder Strap, Safety Goggles, Nylon Cord

**LM001JM101** 480mm (18-7/8") Cordless Lawn Mower

New

High power cordless lawn mower powered by 64Vmax (57.6V) Li-Ion battery



Cutting Width	480 mm (18-7/8")
Cutting Height	20 - 100 mm (13/16 - 3-15/16")
Grass Box Capacity	62 L
No Load Speed (RPM)	2,500 - 3,200
Actual Mowing Area	1,400 m <sup>2</sup>
Continuous Use (min.)	34
Vibration Level	2.5 m/s <sup>2</sup> or less
Dimensions (L x W x H)	1,600 - 1,680 x 540 x 955 - 1,080 mm (63 - 66 x 21-1/4 x 37-1/2 - 42-1/2")
Net weight	24.4 - 26.1 kg

64Vmax



Blade, Mulching Plug, Socket Wrench, Rod, Battery, Charger

**BL6440**

Powerful battery optimized for the Makita battery powered lawn mower



Powered by 64Vmax Li-Ion battery



Handle height adjustment



Control panel

- 3 cutting modes
- (No load speed)
  - Normal mode
    - LM001J: 3,200
    - LM002J: 2,800
  - Soft no-load mode
    - LM001J: 2,500 / 3,200
    - LM002J: 2,300 / 2,800
  - Noise reduction mode
    - LM001J: 2,500
    - LM002J: 2,300



Grass level indicator



Can be stored vertically



Tool-less foldable handle



Plastics Deck



photo: LM002J

Higher mowing performance

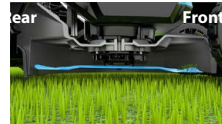

The blade is designed so that it tilts towards the front side of the mower when attached, preventing double-cutting for reduced current consumption.



Optimum blade design for less rotational speed reduction of the blade

BL MOTOR

XPT



IPX4-rated water-resistance

10 cutting height settings from 20mm to 100mm



Cutting width  
LM001J: **480mm**  
LM002J: **534mm**

LM001J  
Mowing area  
**1,400 m<sup>2</sup>**

LM002J  
Mowing area  
**1,600 m<sup>2</sup>**

Collecting	Mulching	Rear discharge	Side discharge
✓	✓	✓	—

**LM002JM101** 530mm (21") Cordless Lawn Mower

New

High power cordless lawn mower powered by 64Vmax (57.6V) Li-Ion battery



Cutting Width	534 mm (21")
Cutting Height	20 - 100 mm (13/16 - 3-15/16")
Grass Box Capacity	70 L
No Load Speed (RPM)	2,300 - 2,800
Actual Mowing Area	1,600 m <sup>2</sup>
Continuous Use (min.)	39
Vibration Level	2.5 m/s <sup>2</sup> or less
Dimensions (L x W x H)	1,710 - 1,800 x 585 x 985 - 1,115 mm (67-1/2 - 71 x 23 x 38-3/4 - 44")
Net weight	25.7 - 27.6 kg

64Vmax



Blade, Mulching Plug, Socket Wrench, Rod, Battery, Charger

**LM001CZ** 534mm (21") Battery Powered Lawn Mower

Mows 5,700 m<sup>2</sup> with PDC1200



Cutting Width	534mm (21")
Cutting Height	20 - 100 mm (13/16 - 3-15/16")
No Load Speed (RPM)	2,300 - 2,800
Propelling Speed	2.5 - 5.0 km/h
Actual Mowing Area	w/ PDC01, Self-Propelled: 1,700 m <sup>2</sup>
*PDC01 (BL1860B X4)	w/ PDC01, push-drive: 2,300 m <sup>2</sup>
	w/ PDC1200, Self-Propelled: 4,200 m <sup>2</sup>
	w/ PDC1200, push-drive: 5,700 m <sup>2</sup>
Continuous Use (min.)	w/ PDC01, Self-Propelled: 100
*PDC01 (BL1860B X4)	w/ PDC1200, Self-Propelled: 100
	w/ PDC1200, push-drive: 130
Dimensions (L x W x H)	1,630 - 1,715 x 590 x 990 - 1,095mm
Net weight	41.9 - 49.2 kg (92.4 - 108.5 lbs.)



Shoulder Belt, End Nozzle, Flat Nozzle (country-specific), Extension Nozzle (country-specific), Adapter Pipe (country-spec)



**DLM539Z** 534mm (21") Cordless Lawn Mower

New

18V X2 (36V) BL Brushless Cordless 53 cm (21") Lawn Mower

Li-ion Ah 6.0 5.0 3.0 1.5



Cutting Width	534 mm (21")
Cutting Height	20 - 100 mm (13/16" - 3-15/16")
No Load Speed (RPM)	3,000
Propelling Speed	2.5 - 5.0 km/h
Actual Mowing Area	w/ BL1860B x2, Self-Propelled: 700 m <sup>2</sup> w/ BL1860B x2, Push-Drive: 800 m <sup>2</sup>
Continuous Use (min.)	w/ BL1860B x2, Self-Propelled: 22 w/ BL1860B x2, Push-Drive: 25
Dimensions (L x W x H)	During Operation: 1,810 - 1,870 x 580 x 920 - 1,040 mm
Net weight	28.0 - 30.5 kg

18V x2



Blade, Mulch Plug, Socket Wrench, Rod, Battery, Charger, Z: Battery and Charger are sold separately

**DLM538Z** 534mm (21") Cordless Lawn Mower

New

18V X2 (36V) BL Brushless Cordless 53 cm (21") Lawn Mower

Li-ion Ah 6.0 5.0 3.0 1.5



Cutting Width	534 mm (21")
Cutting Height	20 - 100 mm (13/16" - 3-15/16")
No Load Speed (RPM)	3,000
Actual Mowing Area	w/ BL1860B x2, Push-Drive: 800 m <sup>2</sup>
Continuous Use (min.)	w/ BL1860B x2, Push-Drive: 25
Dimensions (L x W x H)	During Operation: 1,810 - 1,870 x 580 x 920 - 1,040 mm
Net weight	25.6 - 28.1 kg (56.4 - 61.9 lbs.)

18V x2



Blade, Mulch Plug, Socket Wrench, Rod, Battery, Charger, Z: Battery and Charger are sold separately

**DLM533Z** 534mm (21") Cordless Lawn Mower

18V X2 (36V) LXT BL Cordless 53 cm (21") Self-Propelled Lawn Mower

Li-ion Ah 6.0 5.0 3.0 1.5



Cutting Width	534 mm (21")
Cutting Height	20 - 100 mm (13/16" - 3-15/16")
No Load Speed (RPM)	2,300 - 2,800
Dimensions (L x W x H)	1,655-1,740x590x 990-1,100 mm (65"-68-1/2"x23- 1/4"x39"-43-1/4")
Net weight	42.8 - 46.7 kg (94.4 - 103 lbs.)

18V x2



Blade, Mulch plug, Socket Wrench, Rod, Battery, Charger, Z: Battery and Charger are sold separately

**DLM532Z / DLM530Z** 534mm (21") Cordless Lawn Mower

18V X2 LXT BL Brushless Cordless Self-Propelled Lawn Mower (DLM532 only)

Li-ion Ah 6.0 5.0 3.0 1.5



Cutting Width	534 mm (21")
Cutting Height	20 - 100 mm (13/16" - 3-15/16")
No Load Speed (RPM)	2,300 - 2,800
Dimensions (L x W x H)	1,630-1,715x590x 990-1,190 mm (64"-67-1/2"x23-1/4"x 39"-46-3/4")
Net weight	DLM530Z: 35.5 - 39.3 kg (78.3 - 86.6 lbs.) DLM532Z: 39.0 - 42.8 kg (86.0 - 94.4 lbs.)

18V x2



Blade, Mulch plug, Side Discharge Mouth, Socket Wrench, Rod, Battery, Charger, Z: Battery and Charger are sold separately

**DLM481Z** 480mm (18-7/8") Cordless Lawn Mower

New

18V X2 (36V) BL Brushless Cordless 48 cm (18-7/8") Lawn Mower

Li-ion Ah 6.0 5.0 3.0 1.5



Cutting Width	480 mm (18-7/8")
Cutting Height	20 - 100 mm (13/16" - 3-15/16")
No Load Speed (RPM)	3,100
Propelling Speed	2.5 - 5.0 km/h
Actual Mowing Area	w/ BL1860B x2, Self-Propelled: 650 m <sup>2</sup> w/ BL1860B x2, Push-Drive: 800 m <sup>2</sup>
Continuous Use (min.)	w/ BL1860B x2, Self-Propelled: 23 w/ BL1860B x2, Push-Drive: 28
Dimensions (L x W x H)	During Operation: 1,690 - 1,740 x 530 x 930 - 1,060 mm
Net weight	27.1 - 29.3 kg

18V x2



Blade, Mulch Plug, Socket Wrench, Rod, Battery, Charger, Z: Battery and Charger are sold separately

**DLM480Z** 480mm (18-7/8") Cordless Lawn Mower

New

18V X2 (36V) BL Brushless Cordless 48 cm (18-7/8") Lawn Mower

Li-ion Ah 6.0 5.0 3.0 1.5



Cutting Width	480 mm (18-7/8")
Cutting Height	20 - 100 mm (13/16" - 3-15/16")
No Load Speed (RPM)	3,100
Actual Mowing Area	w/ BL1860B x2, Push-Drive: 800 m <sup>2</sup>
Continuous Use (min.)	w/ BL1860B x2, Push-Drive: 28
Dimensions (L x W x H)	During Operation: 1,690 - 1,740 x 530 x 930 - 1,060 mm
Net weight	24.5 - 26.8 kg (54.0 - 59.1 lbs.)

18V x2



Blade, Mulch Plug, Socket Wrench, Rod, Battery, Charger, Z: Battery and Charger are sold separately

**DLM462Z** 460mm (18") Cordless Lawn Mower

18V X2 LXT BL Brushless Cordless 46 cm (18") Self-Propelled Lawn Mower

Li-ion Ah 6.0 5.0 3.0 1.5



Cutting Width	460 mm (18")
Cutting Height	20 - 100 mm (13/16" - 3-15/16")
No Load Speed (RPM)	2,500 - 3,300
Propelling speed	2.5 - 5.0 km/h
Dimensions (L x W x H)	1,610-1,690x535x 980-1,095 mm (63-1/2"-66-1/2"x 21"x39"-43")
Net weight	35.3 - 39.0 kg (77.8 - 86.0 lbs.)

18V x2



Blade, Mulch plug, Socket Wrench, Rod, Battery, Charger, Z: Battery and Charger are sold separately

**DLM460Z** 460mm (18") Cordless Lawn Mower

Brushless Cordless 46 cm (18") 3-in-1 Mower

Li-ion Ah 6.0 5.0 3.0 1.5



Blade Type	2 Tooth
Hole Diameter	10.0 mm (3/8")
Cutting Width	460 mm (18")
Cutting Height	20-75mm (13/16"-2-5/16")
No Load Speed (RPM)	2,500 - 3,300
Recommended mowing area	w/ BL1860B x2: 800 - 1,600 m <sup>2</sup>
Continuous Use (min.)	w/ BL1860B / BL1850B / BL1840B/BL1830B/BL1820B/ BL1815N21/18/14/10/8/6
Sound Power Level	91 dB(A)
Dimensions (L x W x H)	1,319-1,518x532x 879-1,138 mm
Net weight	25.3 - 27.6 kg (55.8 - 60.8 lbs.)

18V x2



Blade, Socket Wrench, Battery, Fast Charger, Z: Battery and Charger are sold separately

**DLM432Z 430mm (17") Cordless Lawn Mower**

2-in-1 Mower

Li-ion Ah 6.0 5.0 3.0 1.5



Cutting Width	430 mm (17")
Cutting Height	20 - 75 mm (13/16" - 2-15/16")
No Load Speed (RPM)	3,600
Dimensions (L x W x H)	1,435-1,490x460x 1,005-1,045 mm (56-1/2"-58-3/4"x18- 1/8"x39-1/2"-41-1/4")
Net weight	16.8 - 17.5 kg (36.6 - 38.6 lbs.)

18V x2



Blade, Wrench, Battery, Charger Z: Battery and Charger are sold separately

**DLM382CF2 / Z 380mm (15") Cordless Lawn Mower**

2-in-1 Mower

Li-ion Ah 6.0 5.0 3.0 1.5



Cutting Width	380 mm (15")
Cutting Height	20 - 75 mm (13/16" - 2-15/16")
No Load Speed (RPM)	3,700
Dimensions (L x W x H)	1,380-1,410x450x 985-1,005 mm (54-1/4"-55-1/2"x17- 3/4"x38-3/4"-39-1/2")
Net weight	16.2 - 16.9 kg (35.7 - 37.3 lbs.)

18V x2



Blade, Wrench, Battery, Charger

**DLM330RG / Z 330mm (13") Cordless Lawn Mower**

New

18V LXT Li-Ion Cordless 330 mm (13") 3 in 1 Lawn Mower

Li-ion Ah 6.0 5.0 3.0 1.5



Cutting Width	330 mm (13")
Cutting Height	20 - 75 mm (13/16" - 2-15/16")
Grass Box Capacity	30 L
No Load Speed (RPM)	4,300
Actual Mowing Area	w/ BL1840B: 270 m <sup>2</sup>
Continuous Use (min.)	w/ BL1840B: 14
Wheel Size	Front / Rear: 140 / 180 mm (5-1/2" / 7-1/8")
Dimensions (L x W x H)	During Operation: 1,285 - 1,350 x 375 x 935 - 975 mm, When Stored (w/o Grass Box): 520 x 375 x 775 mm
Net weight	11.6 - 12.5 kg

18V



Blade, Mulching Plug, Wrench, Battery, Charger, Z: Battery and Charger are sold separately

**DLM230RG / Z 230mm (9") Cordless Lawn Mower**

New

18V LXT Cordless 23 cm (9") 2-in-1 Lawn Mower

Li-ion 6.0 5.0 3.0 1.5



Cutting Width	230 mm (9")
Cutting Height	10 - 55 mm
Grass Box Capacity	20 L
No Load Speed (RPM)	7,000
Actual Mowing Area	w/ BL1830B: 90 m <sup>2</sup>
Continuous Use (min.)	w/ BL1830B: 6 min
Wheel Diameter	130 / 55 mm
Dimensions (L x W x H)	During Operation: 860 - 1,105 x 256 x 680 - 920 mm, When Stored (w/o Grass Box): 264 x 363 x 780 mm
Net weight	8.6 - 8.9 kg

18V



Blade, Hex wrench, Rod, Battery, Charger, Z: Battery and Charger are sold separately

**ELM4620 460mm (18-1/8") Electric Lawn Mower**

1,800N 4-in-1 Electric Mower



Continuous rating input	1,800W
Cutting Width	460 mm (18-1/8")
Cutting Height	20-75mm(13/16"-2-15/16")
No Load Speed (RPM)	2,950
Recommended mowing area up to	800 m <sup>2</sup>



Blade, Wrench, Mulch Plug

**ELM4121 410mm (16-1/8") Electric Lawn Mower**

Stays upright for easy maintenance and cleaning



Continuous rating input	1,600W
Cutting Width	410 mm (16-1/8")
Cutting Height	20-75mm(13/16"-2-15/16")
No Load Speed (RPM)	3,400
Recommended mowing area up to	600 m <sup>2</sup>



Blade, Wrench, Mulch Plug, Side Discharge Mouth

**ELM3720 370mm (14-1/2") Electric Lawn Mower**

Stays upright for easy maintenance and cleaning



Continuous rating input	1,400W
Cutting Width	370 mm (14-1/2")
Cutting Height	20-55mm(13/16"-2-3/16")
No Load Speed (RPM)	3,400
Recommended mowing area up to	500 m <sup>2</sup>



Blade, Wrench

**ELM3320 330mm (13") Electric Lawn Mower**

Stays upright for easy maintenance and cleaning



Continuous rating input	1,200W
Cutting Width	330 mm (13")
Cutting Height	20-55mm(13/16"-2-3/16")
No Load Speed (RPM)	3,400
Recommended mowing area up to	400 m <sup>2</sup>



Blade, Wrench

**DUP361PT2N / ZN**

33mm (1-5/16") Cordless Powered Pruning Shears

Smooth cutting similar to that of a hand pruner

Li-ion Ah 6.0 5.0 3.0 1.5



<b>Max Output Capacity</b>	200W Max cutting : 33mm Max blade opening: 54mm
<b>Dimensions (L x W x H)</b>	305x43x106mm (12"x1-11/16"x4-3/16")
<b>Net weight</b>	0.8 kg (1.8 lbs.)

18V x2

LXT XPT



Oil supply, Wrench set, Diamond file, Cord holder complete (for waist belt), Holster, Harness, Arm band, Tool bag, Shear blade (U), Battery, Fast Charger, Z: Battery and Charger are sold separately

**DUP362PT2N / ZN**

33mm (1-5/16") Cordless Powered Pruning Shears

18V solution for corded power demands

Li-ion Ah 6.0 5.0 3.0 1.5



<b>Max Output Capacity</b>	200W Max cutting : 33mm Max blade opening: 54mm
<b>Dimensions (L x W x H)</b>	305x43x106mm (12"x1-11/16"x4-3/16")
<b>Net weight</b>	0.77 - 0.82 kg (1.7 - 1.8 lbs.)

18V x2

LXT XPT



Oil supply (country-specific), Wrench set, Diamond File, Cord Holder, Holster, Harness, Arm Band, Tool Bag, Battery, Charger, Shear Blade, Z: Battery and Charger are sold separately

**DUS158Z 15L Cordless Garden Sprayer**

New

WetGuard; Excellent water-resistant performance

Li-ion Ah 6.0 5.0 3.0 1.5



<b>Max Pressure</b>	0.5 MPa
<b>Chemical tank</b>	15 L
<b>Hose Length</b>	1.7 m
<b>Continuous Use (min.)</b>	Y-shaped double nozzle: W/BL1830B: 120 Wide angle herbicide nozzle: W/BL1830B: 180
<b>Dimensions (L x W x H)</b>	325 x 237 x 517 mm (12-3/4 x 9-3/8 x 20-3/8")
<b>Net weight</b>	4.6 kg (10.1 lbs.)

18V

LXT WG

Upright Double-Headed Nozzle, Wide-Angle Herbicide Nozzle, Shoulder Harness, Holder, Measure cup, Battery, Charger, Z: Battery and Charger are sold separately

**DUS108Z 10L Cordless Garden Sprayer**

New

WetGuard; Excellent water-resistant performance

Li-ion Ah 6.0 5.0 3.0 1.5



<b>Max Pressure</b>	0.5 MPa
<b>Chemical tank</b>	10 L
<b>Hose Length</b>	1.7 m
<b>Continuous Use (min.)</b>	Y-shaped double nozzle: W/BL1830B: 120 Wide angle herbicide nozzle: W/BL1830B: 180
<b>Dimensions (L x W x H)</b>	325 x 237 x 439 mm (12-3/4 x 9-3/8 x 17-1/4")
<b>Net weight</b>	4.6 kg (10.1 lbs.)

18V

LXT WG

Upright Double-Headed Nozzle, Wide-Angle Herbicide Nozzle, Shoulder Harness, Holder, Measure cup, Battery, Charger, Z: Battery and Charger are sold separately

**DUS054Z 5L Cordless Garden Sprayer**

Two head nozzles for a wide range of spray

Li-ion Ah 6.0 5.0 3.0 1.5



<b>Max Pressure</b>	0.3 MPa (3 kgf/cm <sup>2</sup> )
<b>Chemical tank</b>	5 L
<b>Hose Length</b>	1.7 m
<b>Continuous Use (min.)</b>	Spray Single: w/ BL1860B: 530 min
<b>Dimensions (L x W x H)</b>	340 x 183 x 360 mm (13-3/8 x 7-1/4 x 14-1/8")
<b>Net weight</b>	2.1 kg (4.6 lbs.)

18V

LXT XPT

Shoulder Harness, Holder, Battery, Charger, Z: Battery and Charger are sold separately

**US053DZ 5L Cordless Garden Sprayer**

12Vmax CXT Li-Ion Cordless 5 L Garden Sprayer

Li-ion Ah 4.0 2.0 1.5



<b>Max Pressure</b>	0.3 MPa (3 kgf/cm <sup>2</sup> )
<b>Chemical tank</b>	5 L
<b>Hose Length</b>	1.7 m
<b>Continuous Use (min.)</b>	Spray Single: w/ BL1041B : 250
<b>Dimensions (L x W x H)</b>	340 x 183 x 335 mm (13-3/8 x 7-1/4 x 13-1/4")
<b>Net weight</b>	2.0 kg

12Vmax

CXT XPT

Shoulder Harness, Holder, Battery, Charger, DZ: Battery and Charger are sold separately

**DVF104Z 10L Cordless Garden Sprayer**

Environmentally-friendly with no emission and extremely low noise

Li-ion Ah 6.0 5.0 3.0 1.5



<b>Max pressure</b>	0.3Mpa (3kgf/cm <sup>2</sup> )
<b>Chemical tank</b>	10L
<b>Dimensions (L x W x H)</b>	315x225x415mm (12-3/8"x8-7/8"x16-3/8")
<b>Net weight</b>	3.8 - 4.1kg (8.4 - 9.1lbs)

18V

LXT

Y-shaped Double Nozzle, Wide Angle Nozzle, Spray Pipe Holder, Shoulder Harness, Z: Battery and Charger are sold separately

**DVF154Z 15L Cordless Garden Sprayer**

Environmentally-friendly with no emission and extremely low noise

Li-ion Ah 6.0 5.0 3.0 1.5



<b>Max pressure</b>	0.3Mpa (3kgf/cm <sup>2</sup> )
<b>Chemical tank</b>	15L
<b>Dimensions (L x W x H)</b>	345x235x525mm (13-5/8"x9-1/4"x20-3/4")
<b>Net weight</b>	4.1 - 4.5kg (9.1 - 9.7lbs)

18V

LXT

Y-shaped Double Nozzle, Wide Angle Nozzle, Spray Pipe Holder, Shoulder Harness, Z: Battery and Charger are sold separately



# Cordless Earth Auger DG001G

High performance drilling  
with light weight body



### Reversing switch

enables to extract, in reverse rotation mode, an auger bit jammed in soil with high resistance like clay soil.



### Torque limiter

The torque limiter will actuate when a certain torque level is reached at the low speed setting. The motor will disengage from the output shaft. When this happens, the drill bit will stop turning.

### For larger holes



Work amount  
depth 600mm / BL4040 / on full  
battery charge / low speed mode

ø150mm

about **100** holes

ø200mm

about **65** holes

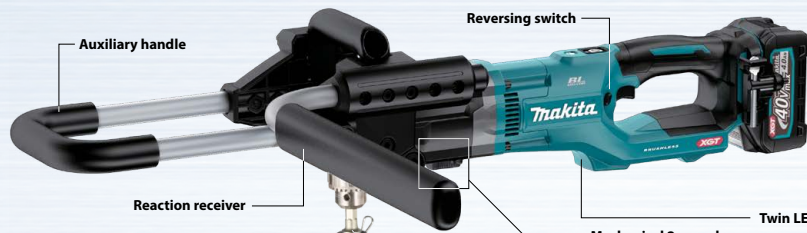

**BL**  
MOTOR  
High power  
Brushless motor



**XPT**  
eXtreme Protection  
Technology



Reversing switch

Auxiliary handle

Reaction receiver

Adapter  
Part No.  
327687-6



Mechanical 2-speed



- 1 Low speed
- 2 High speed

Twin LED job light



Earth auger drill bit

Length: 800mm

ø100  
mm



ø150  
mm



ø200  
mm



**ADT** Automatic torque  
Drive Technology

## DG001GZ02 Cordless Earth Auger

Lightweight design for reduced operator fatigue

Li-ion Ah 8.0 | 5.0 | 4.0 | 2.5 | 2.0



Capacity	Sandy Soil: 200 mm Clay Soil: 150 mm
No Load Speed (RPM)	High / Low: 0 - 1,400 / 0 - 350
Max Fastening Torque	High: 48 N·m (430 in.lbs.) Low: 136 N·m (1,210 in.lbs.)
Dimensions (L x W x H)	846 x 600 x 218 mm (33-1/4 x 23-5/8 x 8-5/8")
Net weight	7.9 kg (17.4 lbs.)

## DDG460ZX4 Cordless Earth Auger

Battery powered and powerful

Li-ion Ah 6.0 | 5.0 | 3.0 | 1.5



Capacity	Sandy Soil: 200 mm Clay Soil: 150 mm
No Load Speed (RPM)	High / Low: 0 - 1,400 / 0 - 350
Max Fastening Torque	High: 48 N·m (430 in.lbs.) Low: 136 N·m (1,210 in.lbs.)
Vibration Level	2.5 m/s <sup>2</sup> or less
Sound Pressure Level	85 dB(A)
Sound Power Level	96 dB(A)
Dimensions (L x W x H)	840 x 607 x 223 mm (33 x 23-7/8 x 8-3/4")
Net weight	7.3 - 8.2 kg (16.1 - 18.1 lbs.)

40Vmax



XPT BL ADT XPT

Chuck Key, Hex Wrench, Adapter, Battery, Charger, Z: Battery and Charger are sold separately

18V x2



XPT BL ADT XPT

Chuck Key, Hex Wrench, Adapter, Battery, Charger, Z: Battery and Charger are sold separately

# CORDLESS COMBO KIT



**New**

**DLX2131JX7**

**18V LITHIUM-ION**

+ 
 + 
 + 
 +

**DLX2414JX3**

**18V LITHIUM-ION**

+ 
 + 
 + 
 +

**DLX2424JX1**

**18V LITHIUM-ION**

+ 
 + 
 + 
 +

**CLX224SAX1**

**12Vmax LITHIUM-ION**

+ 
 + 
 + 
 +

**LCT204**

**10.8V LITHIUM-ION**

+ 
 + 
 + 
 +

**New**

**DLX2051S**

**18V LITHIUM-ION**

+ 
 + 
 +





# CORDLESS TOOLS FOR INDUSTRY

## Screwdriver, Angle Screwdriver

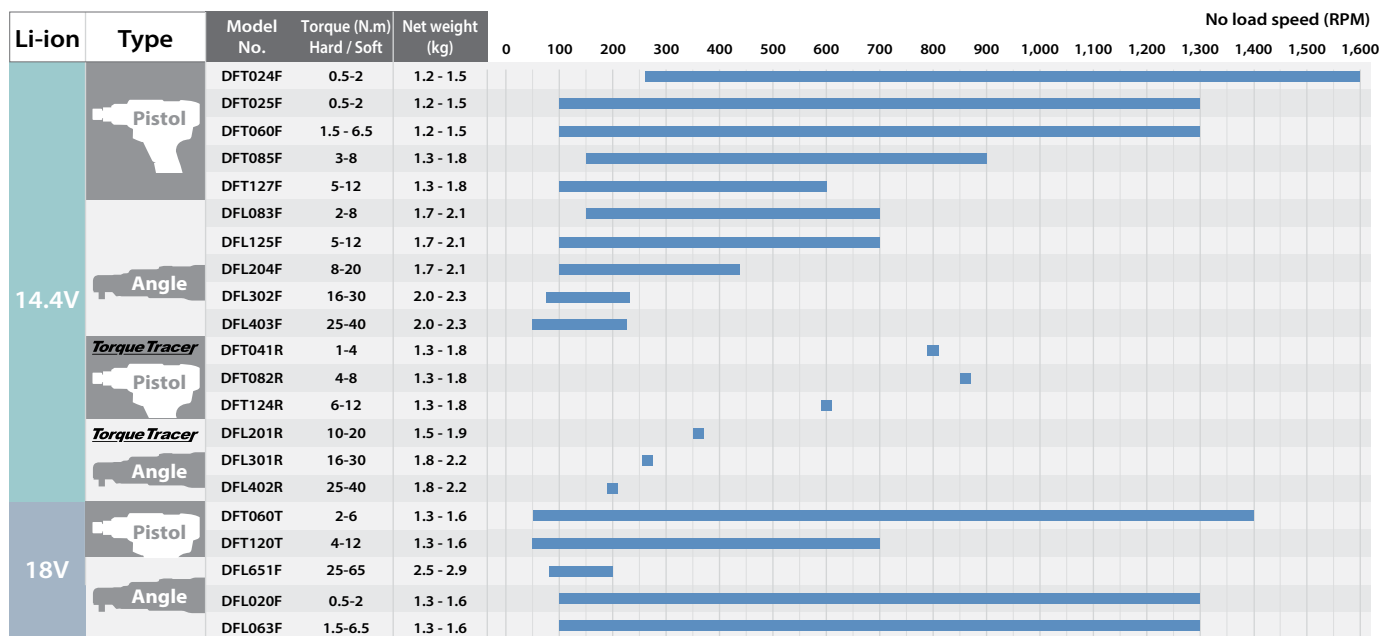

## Impact Driver, Impact Wrench

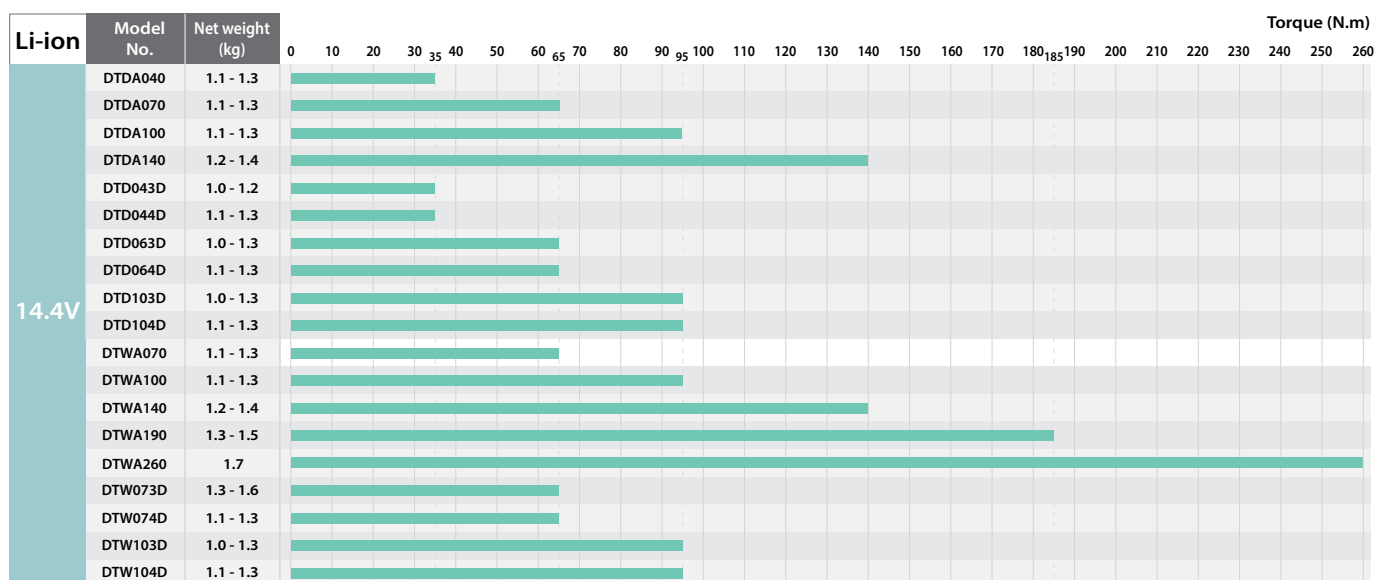



## Battery & Charger Time Reference Chart (in Minutes)

14.4V Lithium-ion		DC18RC (195586-8)	DC18SD (194534-4)	DC18SE (Automotive) (194621-9)	DC24SC (194164-1)
6.0 Ah	BL1460A (632G42-4)	9.6V,12V 14.4V,18V	9.6V,12V 14.4V,18V	9.6V,12V 14.4V,18V	9.6V,12V 14.4V,18V,24V
4.0 Ah	BL1440 (196388-5)	<b>Fast Charging</b> 55 min.	130 min.	130 min.	75 min.
3.0 Ah	BL1430A (194359-6)	36 min.	90 min.	90 min.	-
3.0 Ah	BL1430B (197615-3)	22 min.	60 min.	60 min.	-
1.5 Ah	BL1415NA (196280-5)	22 min.	60 min.	60 min.	-
		15 min.	30 min.	30 min.	20 min.

## MAKSTAR

				DC18RC (195586-8)	DC18SD (194534-4)	DC18SE (Automotive) (194621-9)	DC24WA	DC24SC (194164-1)	
24V Ni-MH		14.4V Ni-MH		12V Ni-MH		9.6V Ni-MH			
3.1 Ah	BH2433 (193739-3)	BH1433 (193354-3)	BH1233C (A-37655)	-	9.6V,12V 14.4V,18V	9.6V,12V 14.4V,18V	9.6V,12V 14.4V,18V	9.6V,12V,14.4V 18V,24V	9.6V,12V,14.4V 18V,24V
					22	70	70	70	30
					BH9033/A : 30min.			BH2433 : 90min.	BH2433 : 60min. DC24SC-BH2433 : 50min.
1.8 Ah	BH2420 (193736-9)	-	BH1220C (193928-0)	*BH9020A (193590-1)	BH9020 (193631-3)	BH9020 (193631-3)			
					15	40	40	40	20
					BH9020/A : 20min.			BH2420 : 55min.	BH2420 : 30min.

( ) Part No. \* Power Display Type

### DFT023FNZ / DFT045FNZ Cordless Screwdriver

14.4V LXT BL Brushless Programmable Cordless 2 N-m (18 In.Lbs.) Screwdriver

Li-ion Ah 6.0 | 5.0 | 3.0 | 1.5



Driving Shank (Hex) 6.35 mm (1/4")  
 No Load Speed (RPM) 400 - 1,300 / 150 - 900  
 Fastening Torque  
 Hard / Soft:  
 DFT023FNZ: 0.5 - 2 / 0.5 - 2 N·m (4 - 18 / 4 - 18 in.lbs.)  
 DFT045FNZ: 1 - 4 / 1 - 4 N·m (9 - 35 / 9 - 35 in.lbs.)  
 Sound Pressure Level 70 dB(A) or less  
 Dimensions (L x W x H) 159x72x232 mm (6-1/4"x2-13/16"x9-1/8")  
 Net weight 1.1 - 1.3 kg (2.4 - 2.9 lbs.)

14.4V



Adjust Grip (country-specific), USB Cable, Z: Battery and Charger are sold separately

### DFT024FNZ Cordless Screwdriver

18V LXT BL Brushless Programmable Cordless Screwdriver

Li-ion Ah 6.0 | 5.0 | 3.0 | 1.5



Driving Shank (Hex) 6.35 mm (1/4")  
 No Load Speed (RPM) 260 - 1,600  
 Fastening Torque  
 Hard / Soft:  
 0.5 - 2 / 0.5 - 2 N·m (4 - 18 / 4 - 18 in.lbs.)  
 w/ BL1830B / BL1840B / BL1850B / BL1860B:  
 161 x 75 x 258 mm (6-3/8 x 2-15/16 x 10-1/8")  
 Net weight 1.2 - 1.5 kg (2.6 - 3.3 lbs.)

18V



Torque Adjust Tool (country-specific), USB Cable (country-specific), Z: Battery and Charger are sold separately

**DFT025FNZ / DFT060FNZ** Cordless Screwdriver

18V LXT BL Brushless Programmable Cordless Screwdriver

Li-ion Ah 6.0 5.0 3.0 1.5



Driving Shank (Hex)	DFT025FNZ: 5 mm (1/4") DFT060FNZ: 6.35 mm (1/4")
No Load Speed (RPM)	100 - 1,300
Fastening Torque	DFT025FNZ: Hard / Soft: 0.5 - 2 / 0.5 - 2 N-m DFT060FNZ: Hard / Soft: 1.5 - 6.5 / 1.5 - 6.5 N-m
Dimensions (L x W x H)	w/ BL1830B / BL1840B / BL1850B / BL1860B: 161 x 75 x 258 mm (6-3/8 x 2-15/16 x 10-1/8")
Net weight	1.2 - 1.5 kg (2.6 - 3.3 lbs.)



Torque Adjust Tool (country-specific), USB Cable (country-specific), Z: Battery and Charger are sold separately

**DFT060TNZ / DFT120TNZ** Cordless Screwdriver

New

18V LXT BL Brushless Programmable Cordless Screwdriver

Li-ion Ah 6.0 5.0 3.0 1.5



No Load Speed (RPM)	DFT060TNZ: 50 - 1,400 DFT120TNZ: 50 - 700
Fastening Torque	DFT060TNZ: 2 - 6 N-m DFT120TNZ: 4 - 12 N-m
Dimensions (L x W x H)	w/ BL1830B / BL1840B / BL1850B / BL1860B: 209 x 72 x 249 mm (6-3/8 x 2-15/16 x 10-1/8")
Net weight	1.3 - 1.6 kg



Z: Battery and Charger are sold separately

**DFT085FNZ / DFT127FNZ** Cordless Screwdriver

14.4V LXT BL Brushless Programmable Cordless Screwdriver

Li-ion Ah 6.0 5.0 3.0 1.5



Driving Shank (Hex)	6.35 mm (1/4")
No Load Speed (RPM)	150 - 900 / 100 - 600
Fastening Torque	Hard / Soft: DFT085FNZ: 3 - 8 / 3 - 8 N-m (27 - 71 / 27 - 71 in.lbs.) DFT127FNZ: 5 - 12 / 5 - 12 N-m (44 - 106 / 44 - 106 in.lbs.)
Sound Pressure Level	70 dB(A) or less
Dimensions (L x W x H)	190x72x237 mm (7-1/2"x2-13/16"x9-3/8")
Net weight	1.3 - 1.8 kg (2.8 - 3.9 lbs.)



Adjust Grip (country-specific), USB Cable, Z: Battery and Charger are sold separately

**DFT126FZ** Cordless Screwdriver

14.4V LXT Li-Ion Cordless 12 N-m (106 in.lbs.) Screwdriver

434

Li-ion Ah 6.0 5.0 3.0 1.5



Driving Shank (Hex)	6.35 mm (1/4")
No Load Speed (RPM)	410
Fastening Torque	Hard / Soft: 5 - 12 N-m
Dimensions (L x W x H)	200x74x235 mm (7-7/8"x2-15/16"x9-1/4")
Net weight	1.3 - 1.8 kg (4.0 - 3.0 lbs.)



Z: Battery and Charger are sold separately

## Li-ion 14.4V Cordless Screw Driver

### Auto-stop system and on-off switch with delayed restarter

Prevent defective on production and keep quality



When a battery is discharged, indication lamp and beeper start warning and then the motor stops automatically

The tool remains still for 1 second after fastening is completed.

### Indication Lamp & Beeper

Warn and prevent errors on production.

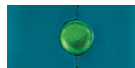

### High Power Motor

- Equipped with high power motor
- Easy to change an armature and carbon brush for high maintenance performance



- Rigid Body
- Optimum Charging System
- Ergonomic Grip
- High accuracy
- LED job light
- ON-OFF Switch with delayed restarter and soft start function
- Torque indication plate

**DFL020FZ / DFL063FZ** Cordless Angle Screwdriver

18V LXT BL Brushless Cordless Angle Screwdriver

Li-ion Ah 6.0 5.0 3.0 1.5



DFL020FZ /  
DFL063FZ

Driving Shank (Square)	9.5 mm (3/8")
No Load Speed (RPM)	DFL020FZ: 100 - 1,300 DFL063FZ: 180 - 1,300
Fastening Torque	Hard / Soft: DFL020FZ: 0.5 - 2 / 0.5 - 2 N-m (4 - 18 / 4 - 18 in.lbs.), DFL063FZ: 1.5 - 6.5 / 1.5 - 6.5 N-m (13 - 58 / 13 - 58 in.lbs.)
Dimensions (L x W x H)	397x74x116 mm (15-5/8"x2-5/16"x4-9/16")
Net weight	1.3 - 1.6 kg (2.9 - 3.6 lbs.)



Adjust Grip (country-specific), USB Cable, Z: Battery and Charger are sold separately

**DFL061FZ / DFL082FZ** Cordless Angle Screwdriver

14.4V LXT Li-Ion Cordless Angle Screwdriver

434

Li-ion Ah 6.0 5.0 3.0 1.5



Driving Shank (Square)	9.5 mm (3/8")
No Load Speed (RPM)	470 / 700
Fastening Torque	Hard / Soft: DFL061FZ: 1.5 - 6 / 1.5 - 6 N-m (13 - 53 / 13 - 53 in.lbs.) DFL082FZ: 2 - 8 / 2 - 8 N-m (18 - 71 / 18 - 71 in.lbs.)
Sound Pressure Level	70 dB(A) or less
Dimensions (L x W x H)	405x74x98 mm (16"x2-15/16"x3-7/8")
Net weight	1.5 - 1.9 kg (3.3 - 4.1 lbs.)



Z: Battery and Charger are sold separately

**DFL083FZ / DFL125FZ / DFL204FZ**  
Cordless Angle Screwdriver

14.4V LXT BL Brushless Cordless Angle Screwdriver

Li-ion Ah 6.0 | 5.0 | 3.0 | 1.5



Driving Shank (Square)	9.5 mm (3/8")
No Load Speed (RPM)	150-700/100-700/100-440
Fastening Torque	Hard / Soft: BFL083FZ: 2-8 / 2-8 N-m BFL125FZ: 5-12 / 5-12 N-m BFL204FZ: 8-20 / 8-20 N-m
Dimensions (L x W x H)	481x74x98 mm (19"x2-15/16"x3-7/8")
Head Height	31.5 mm (1-1/4")
Center Height	16 mm (5/8")
Net weight	1.7 - 2.1 kg (3.8 - 4.7 lbs.)



Adjust Grip (country-specific), Protector (country-specific), USB Cable, Z: Battery and Charger are sold separately

**DFL122FZ / DFL202FZ** Cordless Angle Screwdriver

14.4V LXT Li-Ion Cordless Angle Screwdriver

Li-ion Ah 6.0 | 5.0 | 3.0 | 1.5



Driving Shank (Square)	9.5 mm (3/8")
No Load Speed (RPM)	220 / 410
Fastening Torque	Hard / Soft: BFL122FZ: 8 - 20 / 8 - 20 N-m (71-177 / 71 - 177 in.lbs.) BFL202FZ: 5 - 12 / 5 - 12 N-m (44 - 106 / 44 - 106 in.lbs.)
Sound Pressure Level	70 dB(A) or less
Dimensions (L x W x H)	405x74x98 mm (16"x2-15/16"x3-7/8")
Net weight	1.5 - 1.9 kg (3.4 - 4.2 lbs.)



Z: Battery and Charger are sold separately

**DFL201FZ** Cordless Angle Screwdriver

14.4V LXT BL Brushless Cordless 20 N-m (177 in.lbs.) Angle Screwdriver

Li-ion Ah 6.0 | 5.0 | 3.0 | 1.5



Driving Shank (Square)	9.5 mm (3/8")
No Load Speed (RPM)	360
Fastening Torque	Hard / Soft: 8 - 20 / 8 - 20 N-m (71 - 177 / 71 - 177 in.lbs.)
Vibration Level	Screwdriving w/o Impact: 2.5 m/s <sup>2</sup> or less
Sound Pressure Level	72 dB(A)
Dimensions (L x W x H)	429x72x98 mm (16-7/8"x2-13/16"x3-7/8")
Net weight	1.5 - 2.1 kg (3.3 - 4.5 lbs.)



Z: Battery and Charger are sold separately

**DFL301FZ / DFL402FZ** Cordless Angle Screwdriver

14.4V LXT BL Brushless Cordless Angle Screwdriver

Li-ion Ah 6.0 | 5.0 | 3.0 | 1.5



Driving Shank (Square)	9.5 mm (3/8")
No Load Speed (RPM)	260 / 200
Fastening Torque	Hard / Soft: BFL301FZ: 16 - 30 / 16 - 30 N-m (142 - 266 / 142 - 266 in.lbs.) BFL402FZ: 25 - 40 / 25 - 40 N-m (221 - 354 / 221 - 354 in.lbs.)
Sound Pressure Level	74 dB(A) / 72 dB(A)
Dimensions (L x W x H)	477x72x98 mm (18-3/4"x2-13/16"x3-7/8")
Net weight	1.7 - 2.1 kg (3.8 - 4.6 lbs.)



Z: Battery and Charger are sold separately

**DFL302FZ / DFL403FZ** Cordless Angle Screwdriver

14.4V LXT BL Brushless Cordless Angle Screwdriver

Li-ion Ah 6.0 | 5.0 | 3.0 | 1.5



Driving Shank (Square)	9.5 mm (3/8")
No Load Speed (RPM)	70 - 230 / 50 - 220
Fastening Torque	Hard / Soft: BFL302FZ: 16 - 30 / 16 - 30 N-m (142 - 266 / 142 - 266 in.lbs.) BFL403FZ: 25 - 40 / 25 - 40 N-m (221 - 354 / 221 - 354 in.lbs.)
Dimensions (L x W x H)	518x74x98 mm (20-3/8"x2-15/16"x3-7/8")
Head Height	35 mm (1-3/8")
Center Height	18.5 mm (3/4")
Net weight	2.0 - 2.3 kg (4.4 - 5.2 lbs.)



Adjust Grip (country-specific), Protector (country-specific), USB Cable, Z: Battery and Charger are sold separately

**DFL650FZ** Cordless Angle Screwdriver

18V LXT BL Brushless Cordless 65 N-m (580 in.lbs.) Angle Screwdriver

Li-ion Ah 6.0 | 5.0 | 3.0 | 1.5



Driving Shank (Square)	9.5 / 12.7 mm (3/8 / 1/2")
No Load Speed (RPM)	80 - 200
Fastening Torque	Hard / Soft: 25 - 65 / 25 - 65 N-m (220 - 580 / 220 - 580 in.lbs.)
Vibration Level	Screwdriving without Impact: 2.5 m/s <sup>2</sup> or less
Sound Pressure Level	72 dB(A)
Dimensions (L x W x H)	600x75x116 mm (23-5/8"x2-15/16"x4-9/16")
Net weight	2.4 - 2.9 kg (5.3 - 6.3 lbs.)



Torque Adjustment Tool, USB Cable, Z: Battery and Charger are sold separately

# Touch&Set

Easy to set by smart device

4 stage programmable speed can be set by touching with NFC (Near Field Communication) function of Android.

Near Field Communication  
**NFC**

Photo: DFL650F



**DTDA040Z Cordless Impact Driver**

14.4V LXT BL Brushless Cordless 35 N-m (310 in.lbs.) Impact Driver

Li-ion Ah 6.0 | 5.0 | 3.0 | 1.5



<b>Capacity</b>	<b>Standard Bolt:</b> M5 - M10 (3/16" - 3/8") <b>High Strength Bolt:</b> M5 - M8 (3/16" - 5/16")
<b>No Load Speed (RPM)</b>	0 - 2,400
<b>Impacts Per Minute (IPM)</b>	0 - 3,700
<b>Max Fastening Torque</b>	35 N-m (310 in.lbs.)
<b>Dimensions (L x W x H)</b>	139x74x256 mm
<b>Net weight</b>	1.1 - 1.4 kg (2.4 - 3.1 lbs.)

14.4V



Z: Battery and Charger are sold separately

**DTDA070Z Cordless Impact Driver**

14.4V LXT BL Brushless Cordless 65 N-m (575 in.lbs.) Impact Driver

Li-ion Ah 6.0 | 5.0 | 3.0 | 1.5



<b>Capacity</b>	<b>Standard Bolt:</b> M5 - M12 (3/16" - 1/2") <b>High Strength Bolt:</b> M5 - M10 (3/16" - 3/8")
<b>No Load Speed (RPM)</b>	0 - 2,500
<b>Impacts Per Minute (IPM)</b>	0 - 3,700
<b>Max Fastening Torque</b>	65 N-m (575 in.lbs.)
<b>Dimensions (L x W x H)</b>	139x74x256 mm
<b>Net weight</b>	1.1 - 1.4 kg (2.4 - 3.1 lbs.)

14.4V



Z: Battery and Charger are sold separately

**DTDA100Z Cordless Impact Driver**

14.4V LXT BL Brushless Cordless 95 N-m (840 in.lbs.) Impact Driver

Li-ion Ah 6.0 | 5.0 | 3.0 | 1.5



<b>Capacity</b>	<b>Standard Bolt:</b> M5 - M12 (3/16" - 1/2") <b>High Strength Bolt:</b> M5 - M10 (3/16" - 3/8")
<b>No Load Speed (RPM)</b>	0 - 2,700
<b>Impacts Per Minute (IPM)</b>	0 - 3,300
<b>Max Fastening Torque</b>	95 N-m (840 in.lbs.)
<b>Dimensions (L x W x H)</b>	146x74x256 mm
<b>Net weight</b>	1.2 - 1.5 kg (2.7 - 3.3 lbs.)

14.4V



Z: Battery and Charger are sold separately

**DTDA140Z Cordless Impact Driver**

14.4V LXT BL Brushless Cordless 140 N-m (1,240 in.lbs.) Impact Driver

Li-ion Ah 6.0 | 5.0 | 3.0 | 1.5



<b>Capacity</b>	<b>Standard Bolt:</b> M6 - M16 (1/4" - 5/8") <b>High Strength Bolt:</b> M6 - M12 (1/4" - 1/2")
<b>No Load Speed (RPM)</b>	0 - 2,700
<b>Impacts Per Minute (IPM)</b>	0 - 3,300
<b>Max Fastening Torque</b>	140 N-m (1,240 in.lbs.)
<b>Dimensions (L x W x H)</b>	146x74x256 mm
<b>Net weight</b>	1.2 - 1.5 kg (2.7 - 3.3 lbs.)

14.4V



Z: Battery and Charger are sold separately

**TD043DNZ / TD044DNZ Cordless Impact Driver**

14.4V LXT Li-Ion Cordless Impact Driver

448

Li-ion Ah 3.0 | 1.5



BTD043Z

BTD044Z  
Automatic  
impact stop

<b>Capacity</b>	<b>Machine Screw:</b> M4 - M8 (5/32" - 5/16") <b>Standard Bolt:</b> M5 - M10 (3/16" - 3/8") <b>High Strength Bolt:</b> M5 - M6 (3/16" - 1/4")
<b>No Load Speed (RPM)</b>	0 - 2,300
<b>Impacts Per Minute (IPM)</b>	0 - 3,500
<b>Max Fastening Torque</b>	35 N-m (310 in.lbs.)
<b>Dimensions (L x W x H)</b>	144x74x216 mm
<b>Net weight</b>	TD043DNZ: 1 - 1.2 kg (2.2 - 2.7 lbs.) TD044DNZ: 1.1 - 1.3 kg (2.3 - 2.9 lbs.)

Compatible with only batteries with battery fuel gauge.

14.4V



Z: Battery and Charger are sold separately

**TD063DNZ Cordless Impact Driver**

14.4V LXT Li-Ion Cordless Impact Driver

448

Li-ion Ah 3.0 | 1.5



<b>Capacity</b>	<b>Machine Screw:</b> M4 - M8 (5/32" - 5/16") <b>Standard Bolt:</b> M5 - M12 (3/16" - 1/2") <b>High Strength Bolt:</b> M5 - M10 (3/16" - 3/8")
<b>No Load Speed (RPM)</b>	0 - 2,500
<b>Impacts Per Minute (IPM)</b>	0 - 3,500
<b>Max Fastening Torque</b>	65 N-m (575 in.lbs.)
<b>Dimensions (L x W x H)</b>	144x74x216 mm
<b>Net weight</b>	(5-5/8"x2-15/16"x8-1/2") 1 - 1.3 kg (2.3 - 2.8 lbs.)

Compatible with only batteries with battery fuel gauge.

14.4V



Z: Battery and Charger are sold separately

**TD112DNZ Cordless Impact Driver**

**New**

12Vmax CXT BL Brushless Cordless Impact Driver

Li-ion Ah 4.0 | 2.0 | 1.5



<b>Capacity</b>	<b>Machine screw:</b> M4 - M8 (5/32" - 5/16") <b>Standard Bolt:</b> M5 - M14 (3/16" - 9/16") <b>High Tensile Bolt:</b> M5 - M12 (3/16" - 1/2") <b>Coarse thread (in length):</b> 22 - 90 mm (7/8 - 3-1/2")
<b>No Load Speed (RPM)</b>	Hard / Soft: 0 - 3,000 / 0 - 2,000
<b>Impacts Per Minute (IPM)</b>	Hard / Soft: 0 - 3,900 / 0 - 3,300
<b>Max Fastening Torque</b>	135 N-m (1,200 in.lbs.)
<b>Dimensions (L x W x H)</b>	w/ BL1016/BL1021B: 145 x 64 x 225 mm
<b>Net Weight</b>	1.0 - 1.2 kg (2.2 - 2.7 lbs.)

12Vmax



Phillips Bit, Belt Clip, Battery, Charger, Z: Battery and Charger are sold separately



**TD091DWE Cordless Impact Driver**

10.8V impact driver especially for assembly factory

440

Li-ion Ah 1.3



<b>Capacity</b>	Machine screw: M4 - M8 (5/32" - 5/16") Standard Bolt: M5 - M12 (3/16" - 1/2") High Tensile Bolt: M5 - M10 (3/16" - 3/8") Coarse thread (in length): 22 - 90mm (7/8" - 3-1/2")
No Load Speed (RPM)	0-2,400
Impacts Per Minute (IPM)	0-3,000
Max Fastening Torque	90 N-m (800 in.lbs.)
Dimensions (L x W x H)	134x54x200 mm (5-1/4"x2-1/8"x7-7/8")
Net Weight	0.86 kg (1.9 lbs.)

10.8V



5

Charger, Battery

**DTWA070Z 9.5mm (3/8") Cordless Impact Wrench**

14.4V LXT BL Brushless Cordless 3/8" (9.5 mm) 65 N-m (48 ft.lbs.) Impact Wrench

Li-ion Ah 6.0 5.0 3.0 1.5



<b>Square Drive Capacity</b>	9.5 mm (3/8") Standard Bolt: M5 - M12 (3/16" - 1/2") High Strength Bolt: M5 - M10 (3/16" - 3/8")
No Load Speed (RPM)	0 - 2,500
Impacts Per Minute (IPM)	0 - 3,700
Max Fastening Torque	65 N-m (48 ft.lbs.)
Dimensions (L x W x H)	144x74x256 mm (5-5/8"x2-15/16"x10-1/8")
Net weight	1.1 - 1.4 kg (2.4 - 3.1 lbs.)

14.4V



LXT BL 4

Z: Battery and Charger are sold separately

**DTWA100Z 9.5mm (3/8") Cordless Impact Wrench**

14.4V LXT BL Brushless Cordless 3/8" (9.5 mm) 95 N-m (70 ft.lbs.) Impact Wrench

Li-ion Ah 6.0 5.0 3.0 1.5



<b>Square Drive Capacity</b>	9.5 mm (3/8") Standard Bolt: M5 - M12 (3/16" - 1/2") High Strength Bolt: M5 - M10 (3/16" - 3/8")
No Load Speed (RPM)	0 - 2,700
Impacts Per Minute (IPM)	0 - 3,300
Max Fastening Torque	95 N-m (70 ft.lbs.)
Dimensions (L x W x H)	158x74x256 mm (6-1/4"x2-15/16"x10-1/8")
Net weight	1.2 - 1.5 kg (2.7 - 3.3 lbs.)

14.4V



4

Z: Battery and Charger are sold separately

**DTWA140Z 12.7mm (1/2") Cordless Impact Wrench**

14.4V LXT BL Brushless Cordless 12.7 mm (1/2") 140 N-m (103 ft.lbs.) Impact Wrench

Li-ion Ah 6.0 5.0 3.0 1.5



<b>Square Drive Capacity</b>	12.7 mm (1/2") Standard Bolt: M6 - M16 (1/4" - 5/8") High Strength Bolt: M6 - M12 (1/4" - 1/2")
No Load Speed (RPM)	0 - 2,700
Impacts Per Minute (IPM)	0 - 3,300
Max Fastening Torque	140 N-m (103 ft.lbs.)
Dimensions (L x W x H)	158x74x256 mm (6-1/4"x2-15/16"x10-1/8")
Net weight	1.2 - 1.5 kg (2.7 - 3.3 lbs.)

14.4V



4

Z: Battery and Charger are sold separately

**DTWA190Z 12.7mm (1/2") Cordless Impact Wrench**

14.4V LXT BL Brushless Cordless 12.7 mm (1/2") 185 N-m (136 ft.lbs.) Impact Wrench

Li-ion Ah 6.0 5.0 3.0 1.5



<b>Square Drive Capacity</b>	12.7 mm (1/2") Standard Bolt: M8 - M16 (5/16" - 5/8") High Strength Bolt: M8 - M14 (5/16" - 9/16")
No Load Speed (RPM)	0 - 2,600
Impacts Per Minute (IPM)	0 - 3,000
Max Fastening Torque	185 N-m (136 ft.lbs.)
Dimensions (L x W x H)	158x74x256 mm (6-1/4"x2-15/16"x10-1/8")
Net weight	1.3 - 1.6 kg (2.9 - 3.5 lbs.)

14.4V



4

Z: Battery and Charger are sold separately

**BTW073Z / BTW074Z 9.5mm (3/8") Cordless Impact Wrench**

14.4V LXT Li-Ion Cordless Impact Wrench

448

Li-ion Ah 3.0 1.5



<b>Capacity</b>	Standard Bolt: M5 - M12 (3/16" - 1/2") High Strength Bolt: M5 - M10 (3/16" - 3/8")
No Load Speed (RPM)	0-3,500
Impacts Per Minute (IPM)	0-2,500
Max Fastening Torque	65 N-m (575 in.lbs.)
Dimensions (L x W x H)	144x74x216 mm (5-5/8"x2-15/16"x8-1/2")
Net weight	BTW073Z: 1.3 - 1.6 kg (2.9 - 3.5 lbs.) BTW074Z: 1.1 - 1.3 kg (2.3 - 2.9 lbs.)

Compatible with only batteries with battery fuel gauge.

14.4V



Z: Battery and Charger are sold separately

**BTW103Z / BTW104Z 9.5mm (3/8") Cordless Impact Wrench**

14.4V LXT Li-Ion Cordless Impact Wrench

448

Li-ion Ah 3.0 1.5



<b>Capacity</b>	Standard Bolt: M5 - M12 (3/16" - 1/2") High Strength Bolt: M5 - M10 (3/16" - 3/8")
No Load Speed (RPM)	0-3,500
Impacts Per Minute (IPM)	0-2,700
Max Fastening Torque	95 N-m (841 in.lbs.)
Dimensions (L x W x H)	144x74x216 mm (5-5/8"x2-15/16"x8-1/2")
Net weight	1 - 1.3 kg (2.3 - 2.8 lbs.)

Compatible with only batteries with battery fuel gauge.

14.4V



Z: Battery and Charger are sold separately

**BTW130Z 12.7mm (1/2") Cordless Impact Wrench**

14.4V LXT Li-Ion Cordless Impact Wrench

440

Li-ion Ah 3.0 1.5



<b>Capacity</b>	Standard Bolt: M8 - M16 (5/16" - 5/8") High Strength Bolt: M6 - M12 (1/4" - 1/2")
No Load Speed (RPM)	0-3,200
Impacts Per Minute (IPM)	0-2,300
Max Fastening Torque	130 N-m
Dimensions (L x W x H)	166x79x233mm (6-1/2"x3-1/8"x9-1/8")
Net weight	1.3 - 1.6 kg

Compatible with only batteries with battery fuel gauge.

14.4V



Z: Battery and Charger are sold separately

PRODUCTS



**M6500B 6.5mm (1/4") High Speed Drill**

Compact and lightweight for reduced operator fatigue

64



Continuous Rating Input	230W
Capacity	Steel: 6.5 mm (1/4") Wood: 9 mm (11/32")
No Load Speed (RPM)	0 - 4,500
Sound Pressure Level	72 dB(A)
Dimensions (L x W x H)	200x63x164 mm (7-7/8"x2-1/2"x6-1/2")
Net Weight	0.92 kg (2.0 lbs)
Power Supply Cord	2.0 m (6.6 ft.)



Chuck Key, Chuck Key Holder, Depth Gauge, Cap

**M6001B 10mm (3/8") Drill**

Compact and lightweight for reduced operator fatigue

85



Continuous Rating Input	450W
Capacity	Steel: 10 mm (3/8") Wood: 25 mm (1")
No Load Speed (RPM)	0 - 3,000
Sound Pressure Level	77 dB(A)
Dimensions (L x W x H)	229x64x175 mm (9"x2-1/2"x6-7/8")
Net Weight	1.3 kg (2.9 lbs)
Power Supply Cord	2.0 m (6.6 ft.)



Chuck key

**M0600B 10mm (3/8") Drill**

Powerful 350 W motor for continuous operation

64



Continuous Rating Input	350W
Capacity	Steel: 10 mm (3/8") Wood: 20 mm (13/16")
No Load Speed (RPM)	0 - 3,000
Sound Pressure Level	77 dB(A)
Dimensions (L x W x H)	230x66x176 mm (9"x2-5/8"x6-15/16")
Net Weight	1.2 kg (2.6 lbs)
Power Supply Cord	2.0 m (6.6 ft)



Chuck Key, Chuck Key Holder

**M6600XB 165mm (6-1/2") Mixer**

Powerful 800 W motor for improved mixing performance

303



Continuous Rating Input	800W
Blade Diameter	165 mm (6-1/2")
No Load Speed (RPM)	0 - 700
Sound Pressure Level	85 dB(A)
Sound Power Level	96 dB(A)
Dimensions (L x W x H)	280x86x388 mm (11"x3-3/8"x15-1/4")
Net Weight	2.6 - 2.7 kg (5.7 - 5.9 lbs)
Power Supply Cord	2.0 m (6.6 ft.)



Mixing Blade, Shaft, Top Grip, D-Handle, Wrenches

**M8103B 13mm (1/2") Hammer Drill**

High performance and durability at less expense

85



Continuous Rating Input	430W
Capacity	Concrete: 13 mm (1/2") Steel: 13 mm (1/2") Wood: 18 mm (11/16")
Blows Per Minute (BPM)	0 - 33,000
No Load Speed (RPM)	0 - 3,000
Sound Pressure Level	90 dB(A)
Sound Power Level	101 dB(A)
Dimensions (L x W x H)	255x72x193 mm (10"x2-13/16"x7-5/8")
Net Weight	1.8 kg (3.9 lbs)
Power Supply Cord	2.0 m (6.6 ft)



Side Handle, Depth Gauge, Chuck Key, Chuck Key Holder

**M8103KX2B 13mm (1/2") Hammer Drill**

Ergonomically designed handle with Soft grip

85



Continuous Rating Input	430W
Capacity	Concrete: 13 mm (1/2") Steel: 13 mm (1/2") Wood: 18 mm (11/16")
Blows Per Minute (BPM)	0 - 33,000
No Load Speed (RPM)	0 - 3,000
Sound Pressure Level	90 dB(A)
Sound Power Level	101 dB(A)
Dimensions (L x W x H)	255x72x193 mm (10"x2-13/16"x7-5/8")
Net Weight	1.8 kg (3.9 lbs)
Power Supply Cord	2.0 m (6.6 ft)



Side Handle, Depth Gauge, Chuck Key, Chuck Key Holder



## M0801B 16mm (5/8") Hammer Drill

High performance and durability at less expense

85



Continuous Rating Input	500W
Capacity	Concrete: 16 mm (5/8") Steel: 13 mm (1/2") Wood: 20 mm (13/16")
Blows Per Minute (BPM)	0 - 48,000
No Load Speed (RPM)	0 - 3,200
Sound Pressure Level	94 dB(A)
Sound Power Level	105 dB(A)
Dimensions (L x W x H)	261x69x195 mm (10-1/4"x2-3/4"x7-5/8")
Net Weight	1.7 kg (3.7 lbs)
Power Supply Cord	2.0 m (6.6 ft)



Side Grip, Chuck Key, Chuck Key Holder

## M8100B 16mm (5/8") Hammer Drill

High performance and durability at less expense

85



Continuous Rating Input	710W
Capacity	Concrete: 16 mm (5/8") Steel: 13 mm (1/2") Wood: 30 mm (1-3/16")
Blows Per Minute (BPM)	0 - 48,000
No Load Speed (RPM)	0 - 3,200
Sound Pressure Level	98 dB(A)
Sound Power Level	109 dB(A)
Dimensions (L x W x H)	296x77x202 mm (11-5/8"x3"x8")
Net Weight	2.1 kg (4.6 lbs.)
Power Supply Cord	2.0 m (6.6 ft)



Chuck Key, Side Grip, Depth Gauge

## M8700B 22mm (7/8") Rotary Hammer

Adapted for SDS-PLUS bits

459



Continuous Rating Input	710W
Capacity	Concrete: 22 mm (7/8") Core Bit: 54 mm (2-1/8") Diamond Core Bit (Dry Type): 65 mm (2-9/16") Steel: 13 mm (1/2") Wood: 32 mm (1-1/4")
Blows Per Minute (BPM)	0 - 4,350
No Load Speed (RPM)	0 - 1,100
Dimensions (L x W x H)	362x71x194mm (14-1/4"x2-13/16"x7-5/8")
Net Weight	2.5 - 2.9 kg (5.6 - 6.4 lbs)
Power Supply Cord	2.5 m (8.2 ft)

Tool does not come with bit



Depth gauge, Side grip

## M8701B 26mm (1") Combination Hammer

Adapted for SDS-PLUS bits, 3 operation modes

459



Continuous Rating Input	800W
Capacity	Concrete: 26 mm (1") Core Bit: 68 mm (2-11/16") Diamond Core Bit (Dry Type): 80 mm (3-1/8") Steel: 13 mm (1/2") Wood: 32 mm (1-1/4")
Blows Per Minute (BPM)	0 - 4,500
No Load Speed (RPM)	0 - 1,200
Dimensions (L x W x H)	362x71x194mm (14-1/4"x2-13/16"x7-5/8")
Net Weight	2.7 - 3.1 kg (6.0 - 6.8 lbs)
Power Supply Cord	2.5 m (8.2 ft)

Tool does not come with bit



Side grip, Depth gauge

## M8600B 17mm (11/16") Demolition Hammer

Satisfactory chipping performance

105



Continuous Rating Input	900W
Impact Energy	7.2 J
Blows Per Minute (BPM)	2,900
Sound Pressure Level	95 dB(A)
Sound Power Level	106 dB(A)
Dimensions (L x W x H)	406x99x232 mm (16"x3-7/8"x9-1/8")
Net Weight	5.4 kg (12 lbs)
Power Supply Cord	4.0 m (13.1 ft)



Bull Point, Side Grip, Bit Grease, Cleaning cloth

## M4100B 110mm (4-3/8") Cutter

Redesigned base with grooved back surface for smoother operation

303



Continuous Rating Input	1,200W
Blade Diameter	110 mm (4-3/8")
Max Cutting Capacity	90°: 32 mm (1-1/4")
No Load Speed (RPM)	13,000
Sound Power Level	111 dB(A)
Dimensions (L x W x H)	227x209x166 mm (8-15/16"x8-1/4"x6-1/2")
Net Weight	2.9 kg (6.4 lbs)
Power Supply Cord	2.0 m (6.6 ft.)



Wrench, Water supply fixture, Vinyl tube, Tube holder

## M2401B 355mm (14") Portable Cut-off

Powerful cutting with high power motor

203



Continuous Rating Input	2,000W
Wheel Diameter	355 mm (14")
No Load Speed (RPM)	3,800
Sound Pressure Level	100 dB(A)
Sound Power Level	111 dB(A)
Dimensions (L x W x H)	500x280x620 mm (19-3/4"x11"x24-3/8")
Net Weight	13.7 kg (30.2 lbs.)
Power Supply Cord	2.5 m (8.2 ft.)



Abrasive cut-off wheel, Socket wrench



**M0900B 100mm (4") Angle Grinder**

Two action safety switch for minimizing sudden accidental lock-on

459



Continuous Rating Input	540W
Wheel Diameter	100 mm (4")
No Load Speed (RPM)	12,000
Dimensions (L x W x H)	251x118x97 mm (9-7/8"x4-5/8"x3-13/16")
Net Weight	1.6 kg (3.5 lbs)
Power Supply Cord	2.0 m (6.6 ft)

Tool does not come with depressed center wheel



Lock nut wrench

**M9506B 100mm (4") Angle Grinder**

720W series

459



Continuous Rating Input	720W
Wheel Diameter	100 mm (4")
No Load Speed (RPM)	11,000
Sound Pressure Level	86 dB(A)
Sound Power Level	97 dB(A)
Dimensions (L x W x H)	261x118x101 mm (10-1/4"x4-5/8"x4")
Net Weight	1.6 kg (3.5 lbs)
Power Supply Cord	2.0 m (6.6 ft)



Side Grip, Lock Nut Wrench

**M9509B 100mm (4") Angle Grinder**

High performance and durability at less expense

325



Continuous Rating Input	850W
Wheel Diameter	100 mm (4")
No Load Speed (RPM)	11,000
Sound Pressure Level	87 dB(A)
Sound Power Level	98 dB(A)
Dimensions (L x W x H)	276x118x101 mm (10-7/8"x4-5/8"x4")
Net Weight	1.8 kg (3.9 lbs)
Power Supply Cord	2.0 m (6.6 ft)



Side Grip, Lock Nut Wrench

**M9512B 100mm (4") Angle Grinder**

High performance and durability at less expense

459



Continuous Rating Input	720W
Wheel Diameter	100 mm (4")
No Load Speed (RPM)	11,000
Dimensions (L x W x H)	258x118x101 mm (10-1/8"x4-5/8"x4")
Net Weight	1.6 kg (3.5 lbs.)
Power Supply Cord	2.0 m (6.6 ft)



Lock nut wrench

**M0910B 100mm (4") Angle Grinder**

Design for light duty applications

459



Continuous Rating Input	540W
Wheel Diameter	100 mm (4")
No Load Speed (RPM)	12,000
Dimensions (L x W x H)	251x118x93 mm (9-7/8"x4-5/8"x3-5/8")
Net Weight	1.6 kg (3.4 lbs)
Power Supply Cord	2.0 m (6.6 ft)

Tool does not come with depressed center wheel



Lock nut wrench

**M9513B 100mm (4") Angle Grinder**

High performance and durability at less expense

325



Continuous Rating Input	850W
Wheel Diameter	100 mm (4")
No Load Speed (RPM)	11,000
Dimensions (L x W x H)	273x118x101 mm (10-3/4"x4-5/8"x4")
Net Weight	1.8 kg (4.0 lbs.)
Power Supply Cord	2.0 m (6.6 ft)



Lock nut wrench

**M9510B 115mm (4-1/2") Angle Grinder**

High performance and durability at less expense

325



Continuous Rating Input	850W
Wheel Diameter	115 mm (4-1/2")
No Load Speed (RPM)	11,000
Sound Pressure Level	88 dB(A)
Sound Power Level	99 dB(A)
Dimensions (L x W x H)	276x130x111 mm (10-7/8"x5-1/8"x4-3/8")
Net Weight	2.0 kg (4.5 lbs)
Power Supply Cord	2.0 m (6.6 ft)



Lock nut wrench

**M9508B 125mm (5") Angle Grinder**

Machined bevel gears provide longer service life

459



Continuous Rating Input	720W
Wheel Diameter	125 mm (5")
No Load Speed (RPM)	11,000
Sound Pressure Level	88 dB(A)
Sound Power Level	99 dB(A)
Dimensions (L x W x H)	261x140x111 mm (10-1/4"x5-1/2"x4-3/8")
Net Weight	1.9 kg (4.1 lbs)
Power Supply Cord	2.0 m (6.6 ft)



Side Grip, Lock Nut Wrench

## M9511B 125mm (5") Angle Grinder

High performance and durability at less expense

325



Continuous Rating Input	850W
Wheel Diameter	125 mm (5")
No Load Speed (RPM)	11,000
Sound Pressure Level	89 dB(A)
Sound Power Level	100 dB(A)
Dimensions (L x W x H)	276x140x111 mm (10-7/8"x5-1/2"x4-3/8")
Net Weight	2.0 kg (4.5 lbs)
Power Supply Cord	2.0 m (6.6 ft.)



Lock nut wrench

## M0920B 180mm (7") Angle Grinder

Heavy-duty motor

203



Continuous Rating Input	2,200W
Wheel Diameter	180 mm (7")
No Load Speed (RPM)	8,500
Sound Pressure Level	91 dB(A)
Sound Power Level	102 dB(A)
Dimension (L x W x H)	439x200x141 mm (17-1/4"x7-7/8"x5-9/16")
Net Weight	5.0 kg (11.0 lbs)
Power Supply Cord	2.0 m (6.6 ft.)

Tool does not come with depressed center wheel



Lock nut wrench, Side grip

## M0921B 230mm (9") Angle Grinder

Heavy-duty motor

203



Continuous Rating Input	2,200W
Wheel Diameter	230 mm (9")
No Load Speed (RPM)	6,600
Sound Pressure Level	91 dB(A)
Sound Power Level	102 dB(A)
Dimension (L x W x H)	439x250x141 mm (17-1/4"x9-7/8"x5-9/16")
Net Weight	5.3 kg (11.6 lbs)
Power Supply Cord	2.0 m (6.6 ft.)

Tool does not come with depressed center wheel



Lock nut wrench, Side grip

## M9002B 125mm (5") Angle Grinder

High performance and durability at less expense

303



Continuous Rating Input	1,050W
Wheel Diameter	125 mm (5")
No Load Speed (RPM)	11,000
Sound Pressure Level	91 dB(A)
Sound Power Level	102 dB(A)
Dimension (L x W x H)	361x140x124 mm (14-1/4"x5-1/2"x4-7/8")
Net Weight	2.8 kg (6.1 lbs.)
Power Supply Cord	2.0 m (6.6 ft.)

Tool does not come with depressed center wheel



Depressed center wheel, Lock nut wrench, Side grip

## M9100B 6mm (1/4") Die Grinder

Anti-slip ribs on motor housing for higher maneuverability and better control

411



Continuous Rating Input	480W
Capacity	Collet: 6 mm or 1/4"
Max Wheel Diameter	20 mm (13/16")
No Load Speed (RPM)	33,000
Dimensions (L x W x H)	350x75x75 mm (13-3/4"x2-15/16"x2-15/16")
Net Weight	1.4 kg (3.1 lbs)
Power Supply Cord	2.0 m (6.6 ft)

Tool does not come with wheel point



Wrenches 2, Tool does not come with wheel point

## M5801B 185mm (7-1/4") Circular Saw

Well-balanced and Lightweight for superior handling and performance

303



Continuous Rating Input	1,050W
Blade Diameter	185 mm (7-1/4")
Max Cutting Capacity at 90°	90°: 66 mm (2-5/8") 45°: 44 mm (1-3/4")
No Load Speed (RPM)	4,900
Dimensions (L x W x H)	284x231x243 mm (11-1/8"x9-1/8"x9-9/16")
Net Weight	3.5 kg (7.7 lbs)
Power Supply Cord	2.0 m (6.6 ft.)



Guide rule, Hex wrench, TCT saw blade

## M2300B 255mm (10") Compound Miter Saw

Externally accessible brushes for easy serviceability

JM23000123



Continuous Rating Input	1,500W
Blade Diameter	255 mm (10")
Miter Angle	45° L / 45° R
Bevel Angle	45° L
Max Cutting Capacity	90° Miter: 75 x 130 mm (2-15/16" x 5-1/8") 45° Miter, L/R: 75 x 90 mm (2-15/16" x 3-9/16")
No Load Speed (RPM)	4,200
Sound Power Level	105 dB(A)
Dimensions (L x W x H)	610x485x515 mm (24"x19-1/8"x20-1/4")
Net Weight	14.7 kg (32.5 lbs)
Power Supply Cord	2.5 m (8.2 ft)



Wrench, Dust Bag (Holders x2), Vise Assembly, Triangular Rule, Set Plate

## M4301B Jig Saw

Light duty model with continuous input 450W

64



Continuous Rating Input	450W
Max Cutting Capacity	Wood: 65 mm (2-9/16") at 90° Steel: 6 mm (1/4")
Length of Stroke	18 mm (11/16")
Strokes Per Minute (SPM)	0 - 3,100
Sound Pressure Level	82 dB(A)
Sound Power Level	93 dB(A)
Dimensions (L x W x H)	214x75x202 mm (8-3/8"x2-15/16"x8")
Net Weight	1.9 kg (4.1 lbs)
Power Supply Cord	2.0 m (6.6 ft)



Jig Saw Blade Set, Hex Wrench



M4302B Jig Saw

450 W Top Handle Variable Speed Jig Saw

411



Continuous Rating Input	450W
Max Cutting Capacity at 90°	Wood: 55 mm (2-3/16") Steel: 6 mm (1/4")
Length of Stroke	26 mm (1")
Strokes Per Minute (SPM)	0 - 3,100
Sound Power Level	99 dB(A)
Dimensions (L x W x H)	219x85x191 mm (8-5/8"x3-3/8"x7-1/2")
Net Weight	2.5 kg (5.5 lbs.)
Power Supply Cord	2.0 m (6.6 ft.)



Jig Saw Blade, Hex Wrench

M4500B Recipro Saw

Screw-down blade clamp

303



Screw-down blade clamp

Continuous Rating Input	1,010W
Length of Stroke	28 mm (1-1/8")
Strokes Per Minute (SPM)	0 - 2,800
Capacity	Pipe: 130 mm (5-1/8") Wood: 255 mm (10")
Sound Power Level	99 dB(A)
Dimensions (L x W x H)	457x98x174 mm (18"x3-7/8"x6-7/8")
Net Weight	3.1 kg (6.9 lbs)
Power Supply Cord	2.0 m (6.6 ft)



Recipro saw blade, Hex wrench

M3702B 6mm (1/4") Trimmer

New

Anti-restart function minimizes accidental start-up



Continuous Rating Input	530W
Collet Capacity	6 mm or 1/4"
No Load Speed (RPM)	35,000
Plunge Capacity	0 - 42 mm (0 - 1-5/8")
Sound Power Level	94 dB(A)
Dimension (L x W x H)	82 x 90 x 211 mm (3-1/4" x 3-1/2" x 8-5/16")
Net Weight	1.5 kg (3.3 lbs.)
Power Supply Cord	2.0 m (6.6 ft.)



Collet Cone, Trimmer Guide, Straight Guide Assembly, Templet Guide, Straight Bit, Chip Deflector, Wrench

M3700B 6mm (1/4") Trimmer

Ergonomic slim body design for added comfort and control

411



Continuous Rating Input	530W
Collet Capacity	6 mm or 1/4"
No Load Speed (RPM)	35,000
Plunge Capacity	0 - 42 mm (0 - 1-5/8")
Sound Power Level	94 dB(A)
Dimension (L x W x H)	82x90x199 mm (3-1/4"x3-1/2"x7-7/8")
Net Weight	1.4 kg (3.1 lbs.)
Power Supply Cord	2.0 m (6.6 ft.)



Trimmer Guide Assembly, Straight Guide Assembly, Template Guide, Straight Bit (Carbide-Tipped), Wrenches 2

M3602B Router

New

12 mm (1/2") 1,650 W Plunge Router with Soft Start

203



Continuous Rating Input	1,650W
Collet Capacity	12 mm (1/2")
Collet Size	6, 8, 12 mm (1/4, 3/8, 1/2")
Plunge Capacity	0 - 60 mm (0 - 2-3/8")
No Load Speed (RPM)	22,000
Sound Pressure Level	84 dB(A)
Sound Power Level	95 dB(A)
Dimensions (L x W x H)	148 x 284 x 300 mm (5-7/8" x 11-1/8" x 11-3/4")
Net Weight	5.7 kg (12.6 lbs.)
Power Supply Cord	2.0 m (6.6 ft)



Straight Guide, Templet Guide, Trimmer Guide, Guide Holder, Collet Sleeve, Straight Bit, Wrench, Dust Nozzle (country-specific), Dust Cover (For tool with the knob)



M3601B 8mm (3/8") Router

High performance and durability at less expense

106



Continuous Rating Input	900W
Collet Capacity	6 mm, 8 mm or 1/4"; 3/8"
Plunge Capacity	0 - 35 mm (0 - 1-3/8")
No Load Speed (RPM)	27,000
Sound Pressure Level	91 dB(A)
Sound Power Level	102 dB(A)
Dimensions (L x W x H)	256x110x218 mm (10-1/8"x4-5/16"x8-5/8")
Net Weight	2.7 kg (6.0 lbs)
Power Supply Cord	2.0 m (6.6 ft)



Straight Guide 1/4", Straight Bit, Wrenches 2

M3600B 12mm (1/2") Router

High performance and durability at less expense

203



Continuous Rating Input	1,650W
Collet Capacity	12 mm or 1/2"
Plunge Capacity	0 - 60 mm (0 - 2-3/8")
No Load Speed (RPM)	22,000
Sound Power Level	97 dB(A)
Dimensions (L x W x H)	284x148x300 mm (11-1/8"x5-7/8"x11-3/4")
Net Weight	5.5 kg (12.2 lbs.)
Power Supply Cord	2.0 m (6.6 ft.)



Straight Guide, Guide Holder Assembly, Collet Sleeve (6mm or 1/4"), Collet Sleeve (8mm or 3/8"), Straight Bit, Wrench

## M1100KB 82mm (3-1/4") Planer

V-groove on base for easy chamfer cutting

303



Continuous Rating Input	750W
Planing Width	82 mm (3-1/4")
Planing Depth	3 mm (1/8")
Max Shiplapping	20 mm (3/4")
No Load Speed (RPM)	18,000
Sound Power Level	102 dB(A)
Dimensions (L x W x H)	390x175x140 mm (15-3/8"x6-7/8"x5-1/2")
Net Weight	4.6 kg (10.2 lbs.)
Power Supply Cord	2.0 m (6.6 ft.)



2

Planer Blade, Sharpening Holder Assembly (for resharpenable blade), Blade Gauge, Socket Wrench, Guide Rule

## M1902B 82mm (3-1/4") Power Planer

82mm power planer with excellent cost performance

411



Continuous Rating Input	500W
Planing Width	82 mm (3-1/4")
Planing Depth	1 mm (1/32")
Max Shiplapping	9 mm (11/32")
No Load Speed (RPM)	16,000
Sound Power Level	95 dB(A)
Dimensions (L x W x H)	285x157x160mm (11-1/4"x6-3/16"x6-5/16")
Net Weight	2.7 kg (5.8 lbs)
Power Supply Cord	2.0 m (6.6 ft)

Shiplapping: 9mm (11/32")



2

Planer blade 82, Sharpening Holder Assembly (for unit with resharpenable blade only), Blade gauge assembly, Socket wrench 9, Guide Rule, Dressing stone

## M9204B 125mm (5") Random Orbit Sander

Ergonomically designed palm grip for comfortable handling

419



Continuous Rating Input	240W
Pad Size	123 mm (4-7/8")
Abrasive Paper Size	125 mm (5")
Orbits Per Minute (OPM)	12,000
Strokes Per Minute (SPM)	24,000
Orbit Diameter	2.8 mm (1/8")
Sound Pressure Level	81 dB(A)
Sound Power Level	92 dB(A)
Dimensions (L x W x H)	153x123x144 mm (6"x4-7/8"x5-5/8")
Net Weight	1.2 kg (2.6 lbs)
Power Supply Cord	2.0 m (6.6 ft)



4

Abrasive paper, Dust bag

## M9400B 100mm (4") Belt Sander

High performance and durability at less expense

153



Continuous Rating Input	940W
Belt Size	100 x 610 mm (4" x 24")
Belt Speed	380 m/min (1,250 ft/min)
Sound Pressure Level	87 dB(A)
Sound Power Level	98 dB(A)
Dimensions (L x W x H)	354x175x169 mm (14"x6-7/8"x6-5/8")
Net Weight	6.2 kg (13.7 lbs.)
Power Supply Cord	2.0 m (6.6 ft.)



2

Abrasive belt, Step, Dust bag assembly, Carbon plate

## M9200B Finishing Sander

Extremely versatile sander

419



Continuous Rating Input	180W
Pad Size	112 x 102 mm (4-3/8" x 4")
Abrasive Paper Size	114 x 140 mm (4-1/2" x 5-1/2")
Orbits Per Minute (OPM)	14,000
Sound Pressure Level	79 dB(A)
Dimensions (L x W x H)	110x112x133 mm (4-5/16"x4-3/8"x5-1/4")
Net Weight	0.9 kg (2 lbs)
Power Supply Cord	2.0 m (6.6 ft)



8

Abrasive paper x6

## M9203B Finishing Sander

12,000 OPM for increased efficiency and smooth finish sanding

64



Continuous Rating Input	190W
Pad Size	92 x 185 mm (3-5/8" x 7-1/4")
Abrasive Paper Size	93 x 228 mm (3-5/8" x 9")
Orbits Per Minute (OPM)	12,000
Strokes Per Minute (SPM)	24,000
Orbit Diameter	2.0 mm (1/16")
Sound Pressure Level	75 dB(A)
Dimensions (L x W x H)	252x92x154 mm (9-7/8"x3-5/8"x6-1/16")
Net Weight	1.4 kg (3.2 lbs)
Power Supply Cord	2.0 m (6.6 ft)



3

Abrasive paper #120, Punch Plate, Dust bag

## M4000B Blower

In-line grip for higher maneuverability

85



Continuous Rating Input	530W
Air Volume	1.2-2.9 m <sup>3</sup> /min
No Load Speed (RPM)	8,500 - 16,000
Sound Power Level	101 dB(A)
Dimensions (L x W x H)	427x161x212 mm (16-3/4"x6-3/8"x8-3/8")
Net Weight	1.5 kg (3.4 lbs)
Power Supply Cord	2.0 m (6.6 ft)



3

Nozzle assembly, Sash nozzle

## M4001B Blower

600 W Variable Speed Blower

303



Continuous Rating Input	600W
Max Air Volume	0 - 4.1 m <sup>3</sup> /min
Max Air Velocity	0 - 91 m/s
Air Pressure	0 - 5.7 kPa
No Load Speed (RPM)	0 - 16,000
Sound Power Level	93 dB(A)
Dimensions (L x W x H)	480x185x178 mm (18-7/8"x7-1/4"x7")
Net Weight	1.9 - 2.0 kg (4.3 - 4.5 lbs)
Power Supply Cord	2.0 m (6.6 ft.)



2

Nozzle, Dust Bag

## Makita Cordless Part Number Breakdown

<b>DSE</b>	Charger (DC10WA), 2X7.2V - 1.0Ah Batteries (BL7010)	
<b>DW</b>	Charger (DC10WA), 1X10.8V - 1.3Ah Battery (BL1013)	
<b>DWE</b>	Charger (DC10WA), 2X10.8V - 1.3Ah Batteries (BL1013)	
<b>DWYE</b>	Standard Charger (DC10WD), 2X12Vmax - 1.5Ah Batteries (BL1016)	
<b>DSYE</b>	Fast Charger (DC10SB), 2X12Vmax - 1.5Ah Batteries (BL1016)	
<b>DSAE</b>	Fast Charger (DC10SB), 2X12Vmax - 2.0Ah Batteries (BL1021B)	
<b>DSAJ</b>	Fast Charger (DC10SB), 2X12Vmax - 2.0Ah Batteries (BL1021B), Makpac	
<b>DSME</b>	Fast Charger (DC10SB), 2X12Vmax - 4.0Ah Batteries (BL1041B)	
<b>SYE</b>	Standard Charger (DC18SD), 2X18V - 1.5Ah Batteries (BL1815B)	
<b>RYE</b>	Rapid Charger (DC18RC), 2X18V - 1.5Ah Batteries (BL1815B)	
<b>SF</b>	Standard Charger (DC18SD), 1X18V - 3.0Ah Battery (BL1830B)	
<b>RF</b>	Rapid Charger (DC18RC), 1X18V - 3.0Ah Battery (BL1830B)	
<b>RFE/RF2</b>	Rapid Charger (DC18RC), 2X18V - 3.0Ah Batteries (BL1830B)	
<b>RFJ</b>	Rapid Charger (DC18RC), 2X18V - 3.0Ah Batteries (BL1830B), Makpac	
<b>RME</b>	Rapid Charger (DC18RC), 2X18V - 4.0Ah Batteries (BL1840B)	
<b>RTE/RT2</b>	Rapid Charger (DC18RC), 2X18V - 5.0Ah Batteries (BL1850B)	
<b>RTJ</b>	Rapid Charger (DC18RC), 2X18V - 5.0Ah Batteries (BL1850B), Makpac	
<b>PT2</b>	Dual Port Rapid Charger (DC18RD), 2X18V - 5.0Ah Batteries (BL1850B)	
<b>PG2J</b>	Dual Port Rapid Charger (DC18RD), 2X18V - 6.0Ah Batteries (BL1860B), Makpac	
<b>G2</b>	2X18V - 6.0Ah Batteries (BL1860B)	

### Makita Coding System - Ending Alphabet

**DDF484 R T E**

**Charger**

- S - Standard Charger
- R - Rapid (Fast) Charger
- P - Two Port Charger

**Come with Battery**

- H - 1.3Ah
- Y - 1.5Ah
- A - 2.0Ah
- D - 2.5Ah
- F - 3.0Ah
- M - 4.0Ah
- T - 5.0Ah
- G - 6.0Ah
- L - 8.0Ah

Comes with 2 batteries

- Other:**
- B - Double Insulation
  - C - Electronic Control
  - F - LED Light
  - K - Carrying Case
  - Z - 18V x 2 Tools

**Z**

Tool come with carton box only

For more information, please contact Makita authorised distributor's technical team.



# Combination / Rotary Hammer Drill Capability Chart

		EPTA Weight (kg)																Material for drilling						
		0	10	20	30	40	50	60	70	80	90	100	110	120	130	140	150	160	Highly reinforced concrete	Concrete, granite, stone, brick	Metal/ wood	Working direction	Drilling/ chiselling ratio	
16mm series	HR166D SDS-plus	1.8~2.4																	✓	✓✓✓	✓			
	Diamond core 32 (dry type)																							
17mm series	DHR171 SDS-plus	2.1~2.8																	✓	✓✓✓	✓			
	Diamond core 32 (dry type)																							
18mm series	HR1840/41F SDS-plus	2.0~2.5																	✓	✓✓✓	✓			
	DHR182 SDS-plus	2.4~3.2																	✓	✓✓✓	✓			
Diamond core 32 (dry type)																								
20mm series	DHR202 SDS-plus	3.5																	✓	✓✓✓	✓			
	Diamond core 32 (dry type)																							
22mm series	DHR2230 SDS-plus	2.6																	✓	✓✓✓	✓			
	MT870 SDS-plus	2.5																	✓	✓✓✓	✓			
Diamond core 32 ~ 65 (dry type)																								
23mm series	HR2300 SDS-plus	2.7																	✓	✓✓✓	✓			
	HR2310T SDS-plus	2.9																	✓	✓✓✓	✓			
	HR2320T SDS-plus	2.9																	✓	✓✓✓	✓			
	Diamond core 32 ~ 70 (dry type)																							
24mm series	HR2460 SDS-plus	2.8																	✓	✓✓✓	✓			
	HR2470 SDS-plus	2.9																	✓	✓✓✓	✓			
	DHR241 SDS-plus	3.5																	✓	✓✓✓	✓			
	DHR242 SDS-plus	3.1~3.8																		✓	✓✓✓	✓		
Diamond core 32 ~ 65 (dry type)																								
26mm series	DHR263 SDS-plus	3.5																	✓	✓✓✓	✓			
	HR2600 Series SDS-plus	2.8~2.9																	✓	✓✓✓	✓			
	HR2630 Series SDS-plus	2.8~3.1																	✓	✓✓✓	✓			
	HR2650 Series SDS-plus	3.0~3.2																		✓	✓✓✓	✓		
	HR2661 SDS-plus	3.2																		✓	✓✓✓	✓		
	M8701 SDS-plus	2.7																		✓	✓✓✓	✓		
	Diamond core 32 ~ 80 (dry type)																							
28mm series	HR2800 Series SDS-plus	3.4~3.6																	✓	✓✓✓	✓			
	DHR282 Series SDS-plus	3.9~5.0																	✓	✓✓✓	✓			
	HR001G Series SDS-plus	3.9~4.6																	✓	✓✓✓	✓			
Diamond core 32 ~ 80 (dry type)																								
30mm series	HR3210FCT Series SDS-plus	4.8~5.4																	✓✓✓	✓✓✓	✓			
	Diamond core 32 ~ 90 (dry type)																							
40mm series	HR4002 SDS-max	6.6																	✓✓✓	✓✓✓				
	HR4013C Series SDS-max	6.2~6.8																	✓✓✓	✓✓✓				
	DHR400 SDS-max	7.3~8.1																	✓✓✓	✓✓✓				
	HR005G SDS-max	7.4~7.9																		✓✓✓	✓✓✓			
	Diamond core 32 ~ 90 (dry type)																							
45mm series	HR4511C Series SDS-max	8.2~9.0																	✓✓✓	✓✓✓				
	Diamond core 32 ~ 90 (dry type)																							
50mm series	HR5212C Series SDS-max	10.9~11.9																	✓✓✓	✓✓✓				
	HR006G Series SDS-max	12.9~14.3																	✓✓✓	✓✓✓				
Diamond core 32 ~ 90 (dry type)																								

approx: 50% drilling, 50% chiselling

- Tungsten Carbide-tipped usable range
- Recommended range
- Core bits

- Optimal
- Possible

## Carbon Brush List

Carbon Brush	Part Number	Model								
CB-1	181019-9	903								
CB-51	181021-2	1902	3700B	4300BV	6013BR	6016	6300NB			
CB-55	181026-2	8416	JR3000V							
CB-55A	B-80248									
CB-64	191627-8	6412	6413	6510LVR	9035	906	BO3710	BO4540	DP4700	GD0603
CB-64A	B-80254	GV6010	JV0600K							
CB-65	191628-6	6905B	906H	JS1600	JS1670					
CB-65A	A-81309									
CB-70	191914-5	6501								
CB-70A	A-81212									
CB-85	191998-3	HP1630								
CB-85A	B-80282									
CB-100	181030-1	1100	6906	9045B	9215SB	9218SB	9924DB	JN3200	JS3200	PC1100
CB-100A	B-80298									
CB-106	181410-1	1911B	3620	RP0900	UT1301					
CB-106A	A-81290									
CB-132	191972-1	UC3520A	UC4020A	UC3541A	UC4041A					
CB-153	181044-0	1804N	1805N	2012NB	2416S	3501N	3600H	3601B	3612BR	4107R
CB-153A	B-80329	5008B	5008MG	5016B	5103N	5201N	5401N	5402	6910	9105
		9401	HS0600	LF1000	LS1013	LS1016	LS1019L	LS1040	LS1212	LS1214
		LS1216	LS1219L	LS1440	N5900B	TW1000	UC3530A	UC3531A	UC4030A	UC4051A
CB-173	195483-8	VC2510L	VC3210L							
CB-203	191953-5	2414NB	3612C	HW1200	HW1300	LC1230	LW1400	LW1400	RP1801	
CB-203A	B-80341									
CB-253	194547-5	PC5000C								
CB-303	191963-2	2107F	4100NH	4100NH3Z	4131	5606B	5740NB	5806B	9015B	9016B
CB-303A	B-80379	9227C	9237C	CA5000	DA4000LR	GA5010	GA5020	GA6010	HS7010	HS7600
		JN3201J	JR3050T	JR3060T	JR3070CT	JS3201J	LS0714	PV7000C	UB1100	UB1101
		UB1102	UB1103	UT1305	UT2204					
CB-325	194074-2	9553NB	9556NBG	9556PBG	9556HBG	9556HP	9557NBG	9563H	GA4040	GD0600
		GD0601	GD0602	HR2230	HR2300	HR2310T	HR2320T	HR2460	HR2470	HR2600
		HR2601	HR2610	HR2611FT	HR2630	HR2631FT	HR2800	HR2810		
CB-411	191940-4	3709	3901	4403	6922NB	9031	9500NB	9523NB	DS4011	JN1601
CB-411A	B-80391	KP0800	RT0700C	TD0101F	TW0200	TW0350				
CB-415	191950-1	6904VH								
CB-415A	B-80400									
CB-419	191962-4	4304	4350CT	9035H	BO4510H	BO4556	BO5031	DA3010F	FS2300	FS2500
CB-419A	B-80422	FS2700	FS4300	HP1620	HP2030	HP2050	HP2070	HR1830	HR2020	HR2440
		JS1300	TD0100	UH4570X	UH5570X	UH6570X	UH7580X			
CB-459	194722-3	GA4030	GA4031	GA4034	GA54530	GA4534	GA5030	GA5034	HR1840	HR1841
		JS1000	JS1601	JS1602	PJ7000	TM3000C	TM3010C			
	3641000	HW111								
	3641160	HW102								
	375009-001	SJ401								
	EIB106C	HB500								
	JM23000123	LH1201FL	LS1018L	MLT100						

### Auto Cut - Out Carbon Brush

CB-105	181038-5	HM0810A	HM0810TA	HR2010	HR3520					
CB-105A	B-80307									
CB-155	181048-2	HM1201								
CB-155A	B-80335									
CB-204	191957-7	4112HS	4114S	9617	GA7010C	GA7012C	GA7020	GA7030	GA7040R	GA7040S
CB204A	B-80357	GA9010C	GA9012C	GA9030	GA9030R	GA9040S	GA9050	G55000	HM1302	HM1305
		HM1306	HM1810	SA7000C						
CB-218	197129-2	GA7060	GA7060R	GA7061R	GA7062	GA7063R	GA9060	HM1812		
CB-318	191978-9	9563C	GA4040C	GA4041C	GD0800C	PK5001C	PO6000C	PW5001C	SG1250	SG1251J
CB-327	194285-9	HR3000C								
CB-350	194160-9	HK1820	HM0870C	HM0871C	HR3200C	HR4001C	HR4002	HR4003C	HR4003C	HR4030C

### Carbon Brush for Cordless Tools

CB-430	191971-3	8414D	DCS550	DCO180	BGA450	DGA402	DGA452	DGD800	BHR240	DJN161
CB-438		DJS101	DJS161	DJV180	DPB180	DPJ180	DSS501	BUB360	DUC122	DHR165
		DUB361								
CB-434	193466-2	6932FD	6935FD	BTW121						
CB-440	194427-5	DDA351	DDF442	DDF444	BDF450	BDF452	DDF456	DDF458	DDF482	DFR550
		DFS450	DFS451	BHP442	DHP444	DHP444	BHP450	BHP452	BHP454	DHP456
		DHP458	DHP482	DJS130	BTD142	DTD146	DTP140	DTW152	DTW251	DBN500
		TD091D								
CB-441	194435-6	DHR202	DHR241	DHS630	DJR181	DJR182	DJR186	DKP180	DLS713	DSS610
		DTW450								
CB-442	194928-3	BHR261	BHR262	BUC250	BUH550	BUH650	DHR263	DHS710	DUC252	DUC302
		DUH651								
CB-448	196854-2	DTW152	DTW251							

## How to Maximise Battery Performance

### Rechargeable Tool Battery Don'ts

- **Do not Use the Battery till it is flat :** Using the battery till it is flat, can permanently damage the poles and shorten battery life. Recharge the battery as soon as your tool starts to slow down. Unless you are using a NiCd battery operated tool.
- **Do not Overload the Battery :** Use the cordless tool within specification. Do not overload the cordless tool.
- **Do not Get Battery Wet:** Avoid exposing your batteries to water. Immediately wipe away any moisture on the tool or battery.
- **Do not throw or drop the Battery:** Dropping or throwing the battery may cause damage to battery.



You should stop your operations and charge it when you feel the power is getting lower and lower. This will help to reduce the load to battery and to extend battery lifetime. Never use till empty!!!



### When to CHARGE a Ni-Cd / Ni-MH Battery

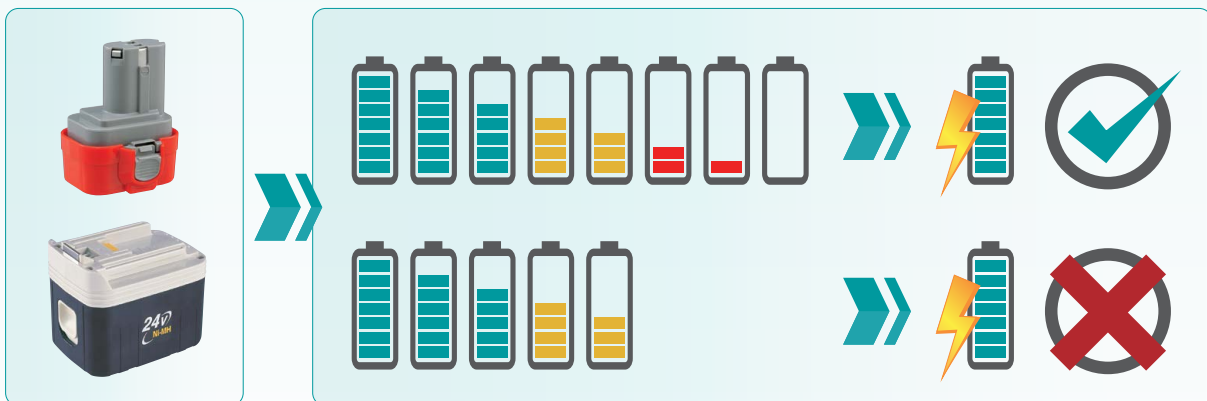



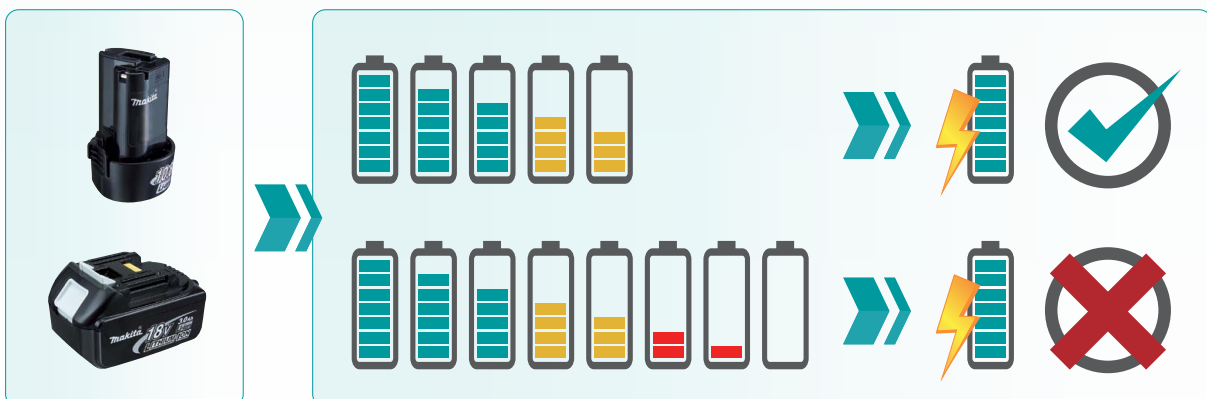





























### When to CHARGE a Li-ion Battery





# Icon

 Double Insulation	 Torque Setting 9	 Bevel Cutting 45 LR	 Chain Brake
 Variable Speed	 Torque Setting 16	 Makita Shank Jig Saw Blade	 Anti Vibration
 Brake	 Torque Setting 18	 Bayonet Shank Jig Saw Blade	 Revolving Hose
 Reversing	 Torque Setting 20	 Laser Marker	 Static Free Hose
 Mechanical 2-Speed	 Torque Setting 21	 Orbital Cutting	 SDS-PLUS Shank
 Mechanical 3-Speed	 Torque Setting 21_41	 Hook & Loop	 SDS-MAX Shank
 Electronic 2-Speed	 Dust Collection	 Depth Adjustment	 17mm Hex Shank
 Electronic 3-Speed	 Torque Limiter	 Sequential and Bump-fire	 21mm Hex Shank
 Electronic 4-Speed	 Constant Speed	 Auto Firing Stop	 28.6mm Hex Shank
 Keyless Chuck	 Soft Start	 Automatic Oiling	 30mm Hex Shank
 Clutch-equipped	 Bevel Cutting 45 left	 Stainless Tank	 Built-in Job Light
 Torque Setting 6	 Bevel Cutting L45 R5		



[www.makita.com.sg](http://www.makita.com.sg)

## TRADEMARKS



Makita Corporation and its affiliates (collectively referred to as "Makita") are the registered owners of the above trademarks and own the exclusive rights to these trademarks. A party who manufactures, advertises, offers for sale, sells, distributes, imports or exports power tools, batteries and/or related accessories using a trademark which is identical or similar to our trademarks may have infringed our trademarks. Makita take a serious view of trademark infringement and will not hesitate to take any legal action against any party who infringes our trademark rights.

### Makita Singapore Pte Ltd

7, Changi South Street 3, Singapore 486348  
 Phone : +65-6546-8700 Fax : +65-6546-8711  
 Email : [msgproductteam@makita.com.sg](mailto:msgproductteam@makita.com.sg)  
 Website : [www.makita.com.sg](http://www.makita.com.sg)



MakitaSG



Visit our website



PRINTED IN SINGAPORE